

*Cut Sheet Printers
Maintenance Manual
Model C40D*



E1195

HP Part No. C4672-90005

Notice

Hewlett-Packard makes no warranty of any kind with regard to this material, including, but not limited to, the implied warranties of merchantability and fitness for a particular purpose. Hewlett-Packard shall not be liable for errors contained herein or for incidental or consequential damages in connection with the furnishing, performance, or use of this material.

Hewlett-Packard assumes no responsibility for the use or reliability of its software on equipment that is not furnished by Hewlett-Packard.

This document contains proprietary information which is protected by copyright. All rights are reserved. No part of this document may be photocopied, reproduced, or translated to another language without the prior written consent of Hewlett-Packard Company. The information contained in this document is subject to change without notice.

Hewlett-Packard Company
System Peripherals Operation
MS 44MC
19111 Pruneridge Avenue
Cupertino, CA 95014

Printing History

New editions are complete revisions of the manual. Update pages, which are issued between editions, contain additional and replacement pages to be merged into the manual by the customer. The date on the title page changes only when a new edition or a new update is published. No information is incorporated into a reprinting unless it appears as a prior update; the edition does not change when an update is incorporated.

The software code printed alongside the date indicates the version level of the software product at the time the manual or update was issued. Many product updates and fixes do not require manual changes and, conversely, manual corrections may be done without accompanying product changes. Therefore, do not expect a one-to-one correspondence between product updates and manual updates.

Edition 1 November 1995

Edition 2 June 1999

Preface

The C40D Maintenance Manual contains all the information needed to maintain and service Hewlett Packard C40D printers. The C40D printer series are high-speed, non-impact printers utilizing electrophotographic imaging technology.

The information in this manual is for authorized field representatives who are familiar with basic printer operations. It serves as a supplement to training classes and provides a basis for discussion with regional field service engineers and customer support representatives.

Using This Manual

This manual is organized into the following sections:

Section 1, Troubleshooting

Reviews the organization of the manual, the way the printer works, and how to troubleshoot the printer, including some standard procedures to follow when troubleshooting. This chapter also includes a chart detailing exactly what each causes each error code, illustrations of all sensors in the printer, and a list of abbreviations used throughout the manual.

Section 2, TAG Cross- Reference Tables

Provides cross-reference tables; look up specific printer problem description (in either the mechanical malfunction, error code, or print quality description tables), then turn to the TAG indicated on the chart to troubleshoot the problem.

Section 3, Troubleshooting Analysis Guides

Detailed step-by-step procedures to help you isolate and resolve specific printer problems. If you are not sure which TAG to start with, begin with the overview, TAG 001.

Section 4, Print Quality Samples

Shows print test patterns indicating specific problems, and referencing the TAG that treats each problem.

Section 5, Diagnostic Tests

Reviews each printer software diagnostic.

Section 6, Wiring Diagrams and Electrical Data

Shows printer schematics and locations of individual components.

Section 7, Removal/Replacement Procedures

Outlines procedures to follow when removing and replacing printer parts, also called FRUs (Field-Replaceable Units).

Section 8, Options

Provides information about the optional High Capacity Input and High Capacity Output bins.

Section 9, General Printer Maintenance

Reviews printer maintenance procedures to complete during service calls.

Index

Provides a list of references to topics mentioned in this manual.

Other Manuals

The *C-Series Illustrated Parts Catalog* shows every FRU and CRU (customer-replaceable unit) in the printer, including part number information. This information is frequently updated.

The *C40D Installation Manual*, C4672-90007, guides you through unpacking, setup, testing, and network configuration of your C40D printer.

The *C40D Operator's Manual*, C4672-90006, contains all the information needed to operate Hewlett Packard C40D printers.

The *C40D Technical Reference Manual*, C4672-60012, is a complete guide to using fonts and the PJI and PostScript emulations on the C40D. It also documents aspects of printer usage in detail.

The *Cut Sheet Printers Paper Specifications Guide*, C4672-90002, explains the various kinds of papers usable in the printer, how to care for them, and how to minimize paper-related problems with the C40D.

Copyright ©1999 Hewlett Packard, Inc. All rights reserved.

November 1995

Please address any comments or questions with respect to this document to:

Publications Manager
System Peripherals Operation
MS 44MC

Hewlett-Packard Company
19111 Pruneridge Avenue
Cupertino, CA 95014

Contents

Troubleshooting

| | |
|--|------|
| Theory of Operation | 1-3 |
| The Printing Process | 1-3 |
| Paper Path and Cycle Sequence | 1-5 |
| Simplex Printing | 1-5 |
| Duplex Printing | 1-6 |
| Sensors and Switches Illustrations | 1-8 |
| Sensor and Switch Listing | 1-8 |
| Troubleshooting | 1-11 |
| General Troubleshooting Tips | 1-12 |
| The Problem: Printer or Host? | 1-12 |
| Running Test Prints | 1-12 |
| Protocol Converters | 1-13 |
| Reading the Error Log | 1-13 |
| Confirming Line Power | 1-14 |
| Using the Troubleshooting Analysis Guide (TAG) | 1-15 |
| Sample TAG | 1-15 |
| Standard Procedures | 1-17 |
| Power-on-reset (POR) | 1-17 |
| Checking Continuity | 1-17 |
| Installing the Interlock By-pass Tool | 1-17 |
| Producing a Developed Image | 1-18 |
| Producing a Toner Patch | 1-18 |
| Completing a Service Call | 1-19 |
| Clearing the Error Log | 1-19 |
| Error Message and Code Technical Definitions | 1-20 |

TAG Cross-Reference Tables

| | |
|--|------|
| Error Code/TAG Cross-Reference | 2-4 |
| Print Quality/TAG Cross-Reference | 2-12 |
| Mechanical Malfunction/TAG Cross-Reference | 2-14 |

Troubleshooting Analysis Guides

| | |
|---|------|
| TAG 001: Troubleshooting a Problem | 3-5 |
| TAG 002: Check Problem Resolution | 3-7 |
| TAG 010: Upper Cassette Malfunction | 3-10 |

Contents

| | |
|---|-------|
| TAG 011: Lower Cassette Malfunction | 3-12 |
| TAG 012: Upper Cassette Not Latched | 3-14 |
| TAG 013: Lower Cassette Not Latched | 3-17 |
| TAG 020: Paper Jam/Misfeed in Upper Cassette Area | 3-19 |
| TAG 021: Paper Jam/Misfeed in Lower Cassette Area | 3-22 |
| TAG 022: Paper Jam in the Transfer or Fuser Area. | 3-26 |
| TAG 023: Paper Jam in the Output Area | 3-30 |
| TAG 025: Paper in Input Area Before Printing | 3-32 |
| TAG 026: Paper in Output Area Before Printing. | 3-34 |
| TAG 030: Developer Bias Short/Failure | 3-36 |
| TAG 031: Toner Patch Reference Level Incorrect. | 3-39 |
| TAG 032: Toner Patch Too Light | 3-41 |
| TAG 035: Out of Toner or ADD TONER Indication | 3-43 |
| TAG 036: Developer Not Installed | 3-45 |
| TAG 040: Photoconductor Seam Sensor Malfunction. | 3-46 |
| TAG 044: Charge Corona/Transfer Corona Circuit Open | 3-49 |
| TAG 045: Charge Corona Circuit Shorted. | 3-52 |
| TAG 047: PC Life Data Error | 3-54 |
| TAG 048: Developer Life Error. | 3-55 |
| TAG 050: Transfer Corona Circuit Shorted. | 3-56 |
| TAG 055: Erase Lamp Malfunction. | 3-58 |
| TAG 070: Fuser Malfunction | 3-60 |
| TAG 071: Open Fuser/Thermistor | 3-65 |
| TAG 072: Fuser Temperature Too High | 3-66 |
| TAG 097: +12 Vdc Power Shorted or Sensing Problem | 3-68 |
| TAG 098: -12 Vdc Power Shorted. | 3-78 |
| TAG 099: +24 Vdc Power Shorted | 3-80 |
| TAG 100: VPCL Board Interface Malfunction | 3-89 |
| TAG 130: Disk Drive Malfunction | 3-90 |
| TAG 200: RIGS Internal Communication Malfunction. | 3-95 |
| TAG 201: RIGS-VPCL Interface Malfunction | 3-97 |
| TAG 405: RIGS Bit-Map RAM Malfunction | 3-99 |
| TAG 500: +5 Vdc Power Malfunction. | 3-100 |
| TAG 600: Vac Power Malfunction | 3-105 |
| TAG 610: Operator Panel Malfunction | 3-112 |

| | |
|--|-------|
| TAG 700: Output Tray Circuit Malfunction | 3-115 |
| TAG 702: Paper Size Detection Malfunction | 3-117 |
| Wiring for the Upper Paper Size Sensor | 3-119 |
| Wiring for the Lower Paper Size Sensor | 3-119 |
| TAG 703: Upper Cassette Malfunction | 3-120 |
| TAG 704: Lower Cassette Malfunction | 3-121 |
| TAG 705: Multiple Paper Feeding | 3-122 |
| TAG 706: Paper Damaged or Wrinkled | 3-123 |
| TAG 707: Upper Paper Guide Assembly Not Closing | 3-124 |
| TAG 750: Counter Malfunction | 3-125 |
| TAG 751: Main Drive Motor Runs Continuously | 3-127 |
| TAG 753: Async IO Communications Malfunction | 3-128 |
| TAG 754: Smart I/O Card Malfunction | 3-131 |
| TAG 800: Prints Blank or With Dark Horizontal Bands | 3-133 |
| TAG 801: Prints Light or Light With Carrier Particles | 3-137 |
| TAG 802: Prints With Voids or White Spots | 3-142 |
| TAG 803: Prints With Light or White Vertical Streaks | 3-144 |
| TAG 804: Prints With Light Horizontal Bands | 3-145 |
| TAG 805: Black Prints | 3-146 |
| TAG 806: Prints with Dark Spots or Scratches | 3-148 |
| TAG 807: Misregistered/Skewed Prints | 3-150 |
| TAG 808: Prints Overtoned/Dark Vertical Streaks | 3-153 |
| TAG 809: Blurred or Smeared Vertical Streaks on Prints | 3-157 |
| TAG 810: Uneven Density or Dark Areas on Prints | 3-161 |
| TAG 811: Background/Residual Images/Dark Prints | 3-162 |
| TAG 812: Uneven or No Fusing on Prints | 3-166 |
| TAG 813: Residual Images on Prints | 3-168 |
| TAG 815: Prints Resulting From Printhead Malfunctions | 3-170 |
| TAG 900: Top Cover Interlock Malfunction, Duplex | 3-171 |
| TAG 901: Misregistration/Skewed Prints (Duplex) | 3-173 |
| TAG 902: Paper Jam in Duplex Area | 3-177 |

Print Quality Samples

| | |
|--|-----|
| Sample 1: Good Quality Print | 4-4 |
| Sample 2: Washout | 4-5 |
| Sample 3: Blank Print | 4-6 |
| Sample 4: Light Print | 4-7 |

Contents

| | |
|---|------|
| Sample 5: Light Print With Background | 4-8 |
| Sample 6: Voids or White Spots | 4-9 |
| Sample 7: Light Vertical Streaks | 4-10 |
| Sample 8: Blank Vertical Bands. | 4-11 |
| Sample 9: Light Horizontal Bands | 4-12 |
| Sample 10: Black or Dark Print | 4-13 |
| Sample 11: Dark Specks, Lines, or Areas | 4-14 |
| Sample 12: Dark Vertical Lines | 4-15 |
| Sample 13: Skewed Prints | 4-16 |
| Sample 14: Misregistration. | 4-17 |
| Sample 15: Overtone Print | 4-18 |
| Sample 16: Blurred Images or Characters | 4-19 |
| Sample 17: Varying Print Density | 4-20 |
| Sample 18: Background | 4-21 |
| Sample 19: Residual Images | 4-22 |
| Sample 20: Wrinkles | 4-23 |
| Sample 21: Fusing Problems | 4-24 |

Diagnostic Tests

| | |
|--|------|
| How to Run Diagnostics. | 5-3 |
| Operator Panel Test | 5-4 |
| Upper Cassette Test | 5-4 |
| Lower Cassette Test | 5-5 |
| Fuser Thermistor Test. | 5-5 |
| Sensor Tests | 5-6 |
| Roller Clutch Tests. | 5-7 |
| Counter Test | 5-7 |
| Jogging Motor Test. | 5-8 |
| Photoconductor Seam Sensor Test. | 5-8 |
| Toner Supply Motor Test | 5-8 |
| Charge Corona Test | 5-9 |
| Transfer Corona Test | 5-9 |
| Erase Lamp Test. | 5-10 |
| Toner Empty Test. | 5-10 |
| Negative Developer Bias Test | 5-11 |
| Duplex Motor Tests | 5-11 |
| Duplex Sensor Tests | 5-12 |
| Duplex Clutch Tests | 5-13 |
| Duplex Tray Paper-Guide Motor Test | 5-13 |

| | |
|---|------|
| High-Capacity Output (HCO) Sensor Tests | 5-14 |
| High-Capacity Input (HCI) Test | 5-14 |
| LED Printhead Test | 5-15 |
| RIGS Board Test | 5-16 |
| Com. Wrap Test | 5-16 |
| Display File Version Test | 5-17 |
| Format Disk | 5-17 |
| Clear Error Log | 5-18 |
| Disk Drive Test | 5-18 |

Wiring Diagrams and Electrical Data

| | |
|---|------|
| Introduction | 6-3 |
| Printhead Circuit Board Settings | 6-3 |
| Connector (J/P) Index | 6-4 |
| Acronyms and Abbreviations | 6-9 |
| Connectors Inside the Front Cover | 6-12 |
| Connectors Inside the Left Cover | 6-13 |
| Connectors on the Duplex Cover | 6-14 |
| Connectors Inside the Right Cover | 6-15 |
| Connectors Inside the Top Cover | 6-16 |
| Connectors on the Back Cover | 6-17 |
| Connectors Inside the Back Cover (J/P2-14) | 6-18 |
| Connectors Inside the Back Cover (Continued) J/P 18-62 | 6-19 |
| Connectors Inside the Back Cover (Continued) J/P 64-85 | 6-20 |
| Connectors Inside the Back Cover (Continued) J/P 90-800 | 6-21 |
| Voltage Isolation Diagrams | 6-22 |
| -12 Vdc Circuits | 6-22 |
| +5 Vdc Circuits | 6-22 |
| +12 Vdc Circuits | 6-24 |
| +24 Vdc Circuits | 6-26 |
| Ground System | 6-27 |
| Host Interface Reference | 6-28 |
| RS-232C Host Interface | 6-28 |
| Standard DCE to DTE RS-232C Cable | 6-29 |
| Special Considerations for RS-232 Host Interface Users | 6-29 |
| DTE Host to Printer (Option 1) | 6-29 |
| DTE Host to Printer (Option 2) | 6-30 |
| IBM PC/XT to Printer | 6-30 |
| IBM PC/AT to Printer | 6-31 |
| Macintosh Communication Port to Printer | 6-31 |

Contents

| | |
|--|------|
| Centronics Parallel Host Interface | 6-33 |
| IBM Parallel to Printer | 6-34 |

Removal/Replacement Procedures

| | |
|--|------|
| Before You Begin | 7-4 |
| Power Considerations | 7-4 |
| Photoconductor Removal | 7-4 |
| Front Cover Removal | 7-5 |
| Back Cover Removal | 7-6 |
| Left Side Cover Removal | 7-7 |
| Right Side Cover Removal | 7-8 |
| Vacuum Transport Unit Removal | 7-9 |
| Rear Duplex Cover Removal | 7-10 |
| Front Duplex Cover Removal | 7-11 |
| Operator Panel Removal | 7-12 |
| Counter Removal | 7-13 |
| RIGS Board Removal | 7-14 |
| VPCL Board Removal | 7-15 |
| Printhead Assembly Removal | 7-16 |
| Printhead Circuit Board (ARIF) Removal | 7-18 |
| Hard Disk Drive Housing Removal | 7-19 |
| Floppy and Hard Disk Drive Removal | 7-20 |
| Cooling Fan Removal | 7-21 |
| Toner Motor Removal | 7-22 |
| This space left blank intentionally | 7-23 |
| AC Power Supply Removal | 7-24 |
| DC Power Supply Removal | 7-26 |
| High Voltage Unit Removal | 7-27 |
| Photoconductor Seam Sensor Removal | 7-28 |
| Photoconductor Rear Guide Rail Removal | 7-30 |
| Power Control Board Removal | 7-33 |
| Upper or Lower Paper Size Sensor Removal | 7-34 |
| Upper Cassette Mount Removal | 7-35 |
| This space left blank intentionally | 7-39 |
| Lower Cassette Mount Removal | 7-40 |
| This space left blank intentionally | 7-44 |
| Upper Paper Guide Removal | 7-45 |
| Upper Paper Guide Roller Removal | 7-47 |

ULower Paper Guide Removal 7-48

Paper Timing Guide Removal 7-49

Cleaner Drive Belt Removal 7-51

Cleaner Drive Removal 7-52

Fuser Drive Belt Removal 7-53

Fuser Drive Removal 7-54

Paper Feed Drive Belt Removal 7-55

Paper Timing Roller Removal 7-56

Upper Feed Roller Removal 7-57

Lower Feed Roller Removal 7-58

Upper Pick-Up Roller Removal 7-59

Pick-Up Roller Drive Idler Removal 7-60

Pick-Up Roller Drive Gear Removal 7-61

Lower Pick-Up Roller Removal 7-62

Exit Assembly Removal 7-63

Exit Pinch Roller Removal 7-65

Upper Static Brush Removal 7-67

Lower Static Brush Removal 7-68

Exit Roller Assembly Removal 7-69

Exit Cover Removal 7-71

Paper Exit Sensor Removal 7-73

Paper Full Sensor Removal 7-74

Front Cover Interlock Switch Removal 7-75

Back Cover Interlock Switch Removal 7-76

Top Cover Interlock Switch Removal 7-77

Erase Lamp Removal 7-78

EP Cover Removal 7-79

Main Motor Removal 7-82

Main Gear Drive Removal 7-85

Duplex Control Board #1 Removal 7-86

Duplex Control Board #2 Removal 7-87

Duplex Tray Registration Motor Removal 7-88

Duplex Skew Correction Cable Removal 7-89

Upper Duplex Drive/Clutch Assembly Removal 7-91

Duplex Route Motor/Solenoid Assembly Removal 7-92

“A” Roller Removal 7-93

Contents

| | |
|--|------|
| “B” Roller Removal | 7-94 |
| “C” Roller Removal | 7-96 |
| “C” Roller Solenoid Removal | 7-97 |
| Duplex Route Separator Removal | 7-98 |
| Duplex Paper Path Sensor Removal | 7-99 |

Options

| | |
|--|------|
| Introduction | 8-3 |
| 1200-Sheet/2500-Sheet Feeder. | 8-4 |
| Guide to Component Acronyms/Physical Locations. | 8-4 |
| Bench Test Procedure. | 8-5 |
| Prefeed Adjustment Procedure | 8-7 |
| 1200-Sheet Feeder Only | 8-7 |
| 2500-Sheet Feeder Only | 8-7 |
| Connection Diagram for 1200-Sheet/2500-Sheet Feeder. | 8-8 |
| Connection Diagram for 1200-Sheet /2500-Sheet Feeder | 8-8 |
| Input Control Board Logic | 8-9 |
| 1400-Sheet Stacker. | 8-10 |
| Guide to Component Abbreviations/Physical Locations. | 8-10 |
| Bench Test Procedure. | 8-11 |
| Connector Locations. | 8-13 |
| Front View (cover removed) | 8-13 |
| Left Side View (left cover removed) | 8-13 |
| Rear Side View (cover removed). | 8-14 |
| Top View (top cover removed) | 8-14 |
| Connection Diagram for the 1400-Sheet Stacker. | 8-15 |
| Output Control Board Logic. | 8-16 |

General Printer Maintenance

| | |
|---|------|
| Introduction | 9-3 |
| Safety Precautions | 9-4 |
| Tool Requirements: Service Kit. | 9-4 |
| Tools/Supplies | 9-5 |
| Printer/Maintenance Record | 9-5 |
| Printer Maintenance Record | 9-6 |
| Every-Call Cleaning Procedure | 9-7 |
| Adjusting Paper Feed Tension | 9-10 |
| Adjusting Registration | 9-11 |
| Lubrication Procedure | 9-12 |

Front View Lubrication 9-13
Front View Lubrication Table 9-14
Rear View Lubrication. 9-15
Rear View Lubrication Table. 9-16
Top View Lubrication 9-17
Duplex Holding Tray Lubrication 9-18
Tune-Up Maintenance Procedure 9-19

Contents

Troubleshooting

Contents

Troubleshooting

| | |
|---|------|
| Theory of Operation | 1-3 |
| The Printing Process | 1-3 |
| Paper Path and Cycle Sequence. | 1-5 |
| Simplex Printing | 1-5 |
| Duplex Printing | 1-6 |
| Sensors and Switches Illustrations | 1-8 |
| Sensor and Switch Listing | 1-8 |
| Troubleshooting | 1-11 |
| General Troubleshooting Tips | 1-12 |
| The Problem: Printer or Host? | 1-12 |
| Running Test Prints | 1-12 |
| Protocol Converters | 1-13 |
| Reading the Error Log | 1-13 |
| Confirming Line Power | 1-14 |
| Using the Troubleshooting Analysis Guide (TAG). | 1-15 |
| Sample TAG | 1-15 |
| Standard Procedures | 1-17 |
| Power-on-reset (POR) | 1-17 |
| Checking Continuity | 1-17 |
| Installing the Interlock By-pass Tool. | 1-17 |
| Producing a Developed Image. | 1-18 |
| Producing a Toner Patch | 1-18 |
| Completing a Service Call | 1-19 |
| Clearing the Error Log | 1-19 |
| Error Message and Code Technical Definitions. | 1-20 |

Section 1

Troubleshooting

The information in this *Field Service Manual* is directed toward authorized field representatives who are familiar with basic printer operations. It serves as a supplement to training classes and provides a basis for discussion with regional field service engineers and customer support representatives.

Theory of Operation

The printer uses an electrophotographic imaging system, which is based on LED array technology. Two key components of the printer are the image generation system (RIGS) controller and the printer control logic (AVPCL) board. A brief description of the function of each of these components follows.

Risc Image Generation System (RIGS) controller: Each printer is equipped with an RIGS controller, which provides the interface between the host computer, the AVPCL board, the interface cards, and the disk drives.

Video Printer Control Logic (AVPCL) board: The AVPCL board directs the mechanical functions of the printer and print cycle timing, and controls the LED printhead. The AVPCL board also receives initial machine information, such as empty paper cassettes, paper jams, and fuser problems.

The Printing Process

The illustration on the following page details the printing process. The numbers represent the sequence of events from the time that the RIGS controller receives data, through the production of a print image, to the preparation for another print.

1 Receiving data

Host data is received through the Signal Interface PCA and passed to the RISC Image Generating System (RIGS) PCA, which temporarily stores the data in RAM. The data may consist of information generated on the host computer and sent over the host communication interface or it may consist of information generated by printer software, such as a request for test prints or to print the directory of the hard disk.

2 Bit Image

The RIGS transforms the host file into a bit map image of 1s and 0s and stores them in bitmap RAM.

3 Charging the photoconductor belt

When the IGS controller receives data, it causes the AVPCL board to turn on the main motor, which rotates the photoconductor belt. As the photoconductor belt rotates, the charge corona applies a high negative charge to it, which repels toner from the photoconductor belt.

4 Exposing the image

The negatively charged belt then passes the LED printhead, where the AVPCL drives the LEDs on and off to discharge the areas of the belt at a density of 300 dots per inch. The 1s in the memory turn the LEDs on; 0s turn the LEDs off. The discharged areas create a latent mirror image of the print on the photoconductor belt.

5 Developing the image

As the photoconductor belt continues to rotate, it brings the latent image to the developer. A negative developer bias is applied to toner and the toner is transferred to the surface of the photoconductor belt. The negatively charged toner (which clings to small metal carrier beads) is attracted to the discharged areas of the belt; the carrier beads do not transfer. The belt, with the developed image on its surface, then rotates out of the developer. At this time you can remove the photoconductor belt and read what is printed on it, which you may need to do when troubleshooting print problems.

6 Activating paper

As the image is being developed, a sheet of paper is transported to the photoconductor belt. The AVPCL board controls this activity. A series of paper pick-up, feed, and timing rollers guide the paper so the developed image is properly registered with the leading edge of the sheet.

7 Transferring the image to the paper

Next, the paper contacts the surface of the photoconductor belt. Above the paper and the belt is the transfer corona, which has a high positive charge, and attracts the developed image from the belt to the surface of the paper. At this point, you can remove the printed image to verify print quality, but the toner is not yet fused.

8 Fusing the image to the paper

The vacuum transport advances the paper with the image to the fuser where heat and pressure bond the toner to the paper. The print then arrives at the paper output tray.

9 Cleaning routine

After a print is made, the photoconductor belt must be cleaned for the next print. The belt first passes the erase lamp where any remaining latent image is erased. The belt continues to the cleaner where a charged brush rotates against the surface to remove any residual toner. This toner is recycled to the developer for reuse.

Paper Path and Cycle Sequence

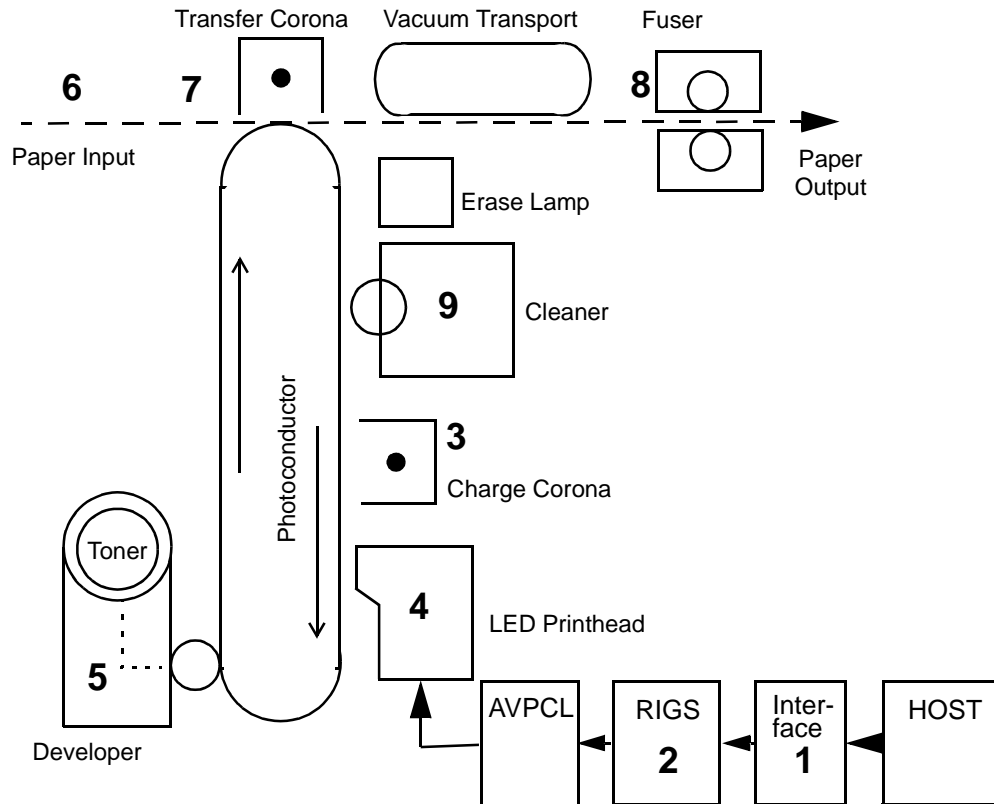

The RIGS board signals the AVPCL board that a page of data is ready to be printed. When this happens the following sequence takes place.

Simplex Printing

- 1 AVPCL software downloaded to the AVPCL board from the disk drive system turns on the main motor.
- 2 The AVPCL board engages the paper pick clutch which causes the roller to feed a sheet of paper.
- 3 The paper is passed to the feed roller where the AVPCL board has engaged the feed roller clutch.
- 4 The feed roller passes the paper to the paper timing roller. Prior to reaching the paper timing roller, the paper passes over the paper timing sensor. If the paper does not energize this sensor in a specified amount of time, a jam error (020/021) will occur. The leading edge of the paper is registered against the paper timing roller. The paper timing clutch is engaged and the paper is passed over the photoconductor for transfer. This registers the paper to the printer and the image to the paper. The paper timing sensor also signals the AVCPCL to begin sending data.
- 5 The AVPCL board engages the paper timing roller clutch and, at the same time, turns on the transfer corona to provide a high positive voltage. The developed image on the photoconductor comes in contact with the paper and the high positive voltage causes the image to transfer to the paper.

Paper Path and Cycle Sequence

- 6 Because the toner is not yet fixed to the paper, a vacuum transport assembly, gripping the paper from the back side, moves the paper to the fuser, where heat and pressure bond the toner to the paper.
- 7 Upon leaving the fuser, the paper comes in contact with the paper exit sensor. (If the paper does not energize this sensor in a given amount of time after leaving the paper timing sensor [step 4], a jam error (022) will occur.)
- 8 The exit roller moves the paper to the exit tray. (If the exit sensor is not cleared in a specified amount of time, a jam error (023) will occur.)

Duplex Printing

When duplex is selected, the AVPCL board controls the paper motion with page scheduling assistance from the RIGS board. The duplex page router is engaged. When in duplex mode, it is important to note that the printer runs multiple pages through the paper path at the same time to increase speed.

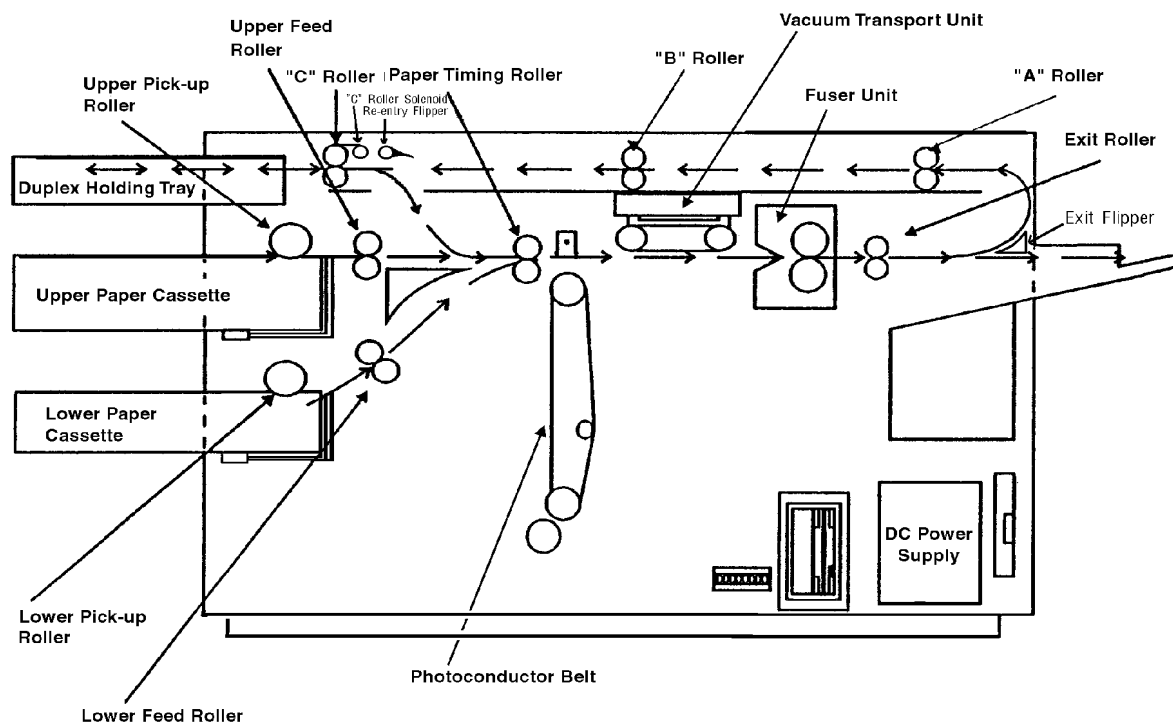

- 1 In a duplex job, the duplex router solenoid behind the fuser is engaged and mechanical fingers route the paper to the duplex area. Also, the "A" roller clutch engages to turn the "A" and "B" rollers (connected via a belt).
- 2 The paper upon passing through the "B" roller comes in contact with the duplex sensor. (If the paper does not energize this sensor in a given amount of time, a jam error (060) will occur.)
- 3 The "C" roller bidirectional motor turns on and passes the paper into the turnaround tray. The paper sensor in the turnaround tray is activated and the paper is center registered. (If the paper does not energize this sensor in a given amount of time after leaving the duplex sensor, a jam error (061) will occur.)

Paper Path and Cycle Sequence

- 4** At this time the solenoid for the router at the turnaround tray engages so the paper can be routed to be printed on the duplex side.
- 5** In a given amount of time after the paper energizes the paper sensor in the turnaround tray, the bidirectional motor reverses and passes the paper to the paper timing roller. (If the paper does not energize the paper timing sensor in a given amount of time after leaving the turnaround sensor, a jam error (062) will occur.)
- 6** At this point, the same steps happen as during a simplex cycle.

Sensors and Switches Illustrations

The following pages illustrate the locations of the printer's sensors and switches.

Sensor and Switch Listing

| Sensor/Switch Name | Page | Sensor/Switch Name | Page |
|--|------|-------------------------------------|------|
| Cassette paper present sensors, upper and lower | 1-8 | Paper exit sensor | 1-10 |
| Cassette present micro switches, upper and lower | 1-8 | Paper full sensor | 1-10 |
| Duplex registration sensor | 1-8 | Paper size sensors, upper and lower | 1-9 |
| Duplex paper path sensor | 1-9 | Paper timing sensor | 1-9 |
| Interlock switch, duplex cover | 1-9 | Photoconductor seam sensor | 1-9 |
| Interlock switch, front | 1-11 | Automatic toner control | 1-10 |
| Interlock switch, rear | 1-9 | Toner empty sensor | 1-10 |
| Interlock switch, top | 1-10 | Toner patch sensor | 1-9 |

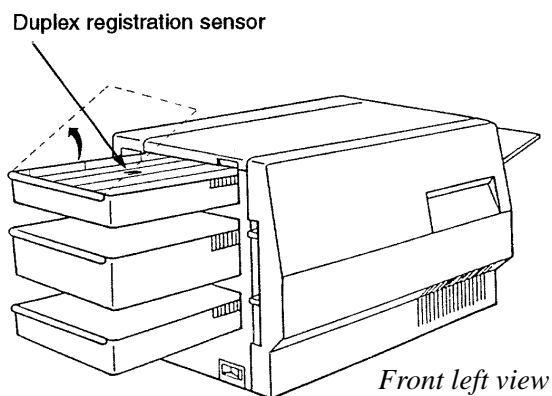
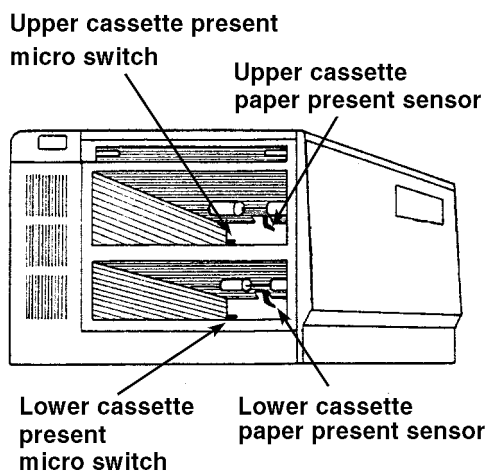

Sensors and Switches Illustrations

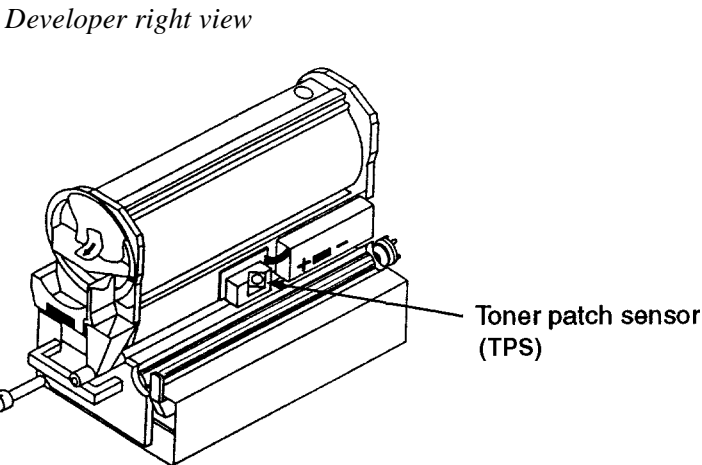
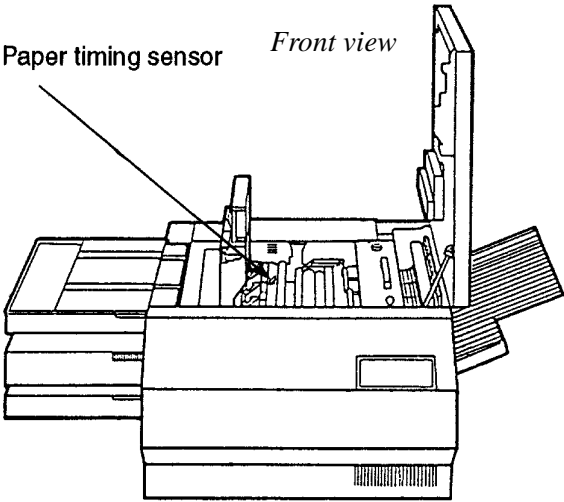
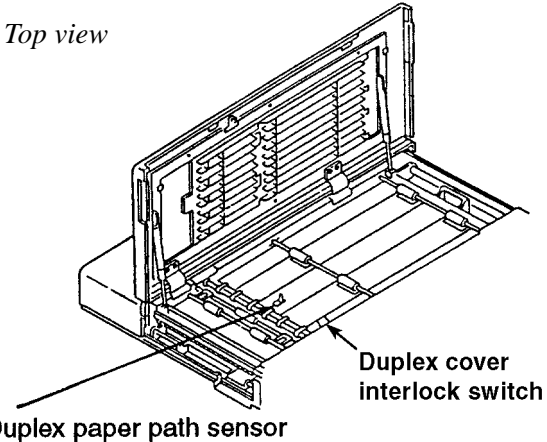
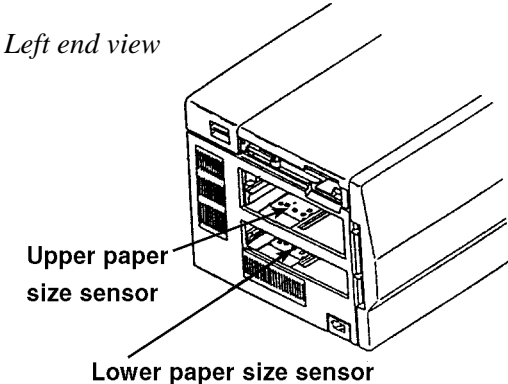
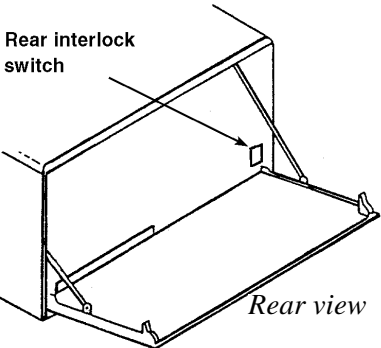

Sensors and Switches Illustrations

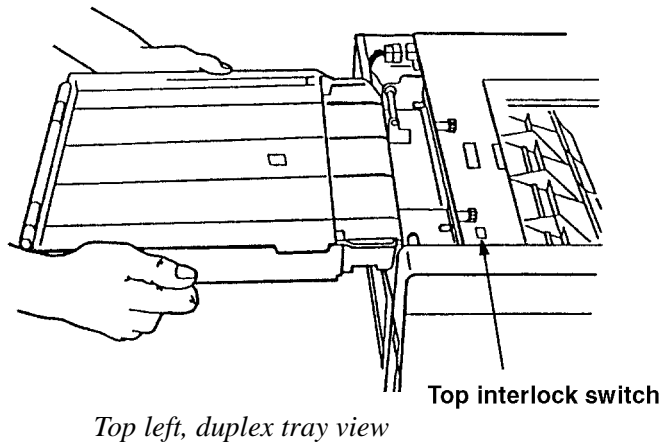
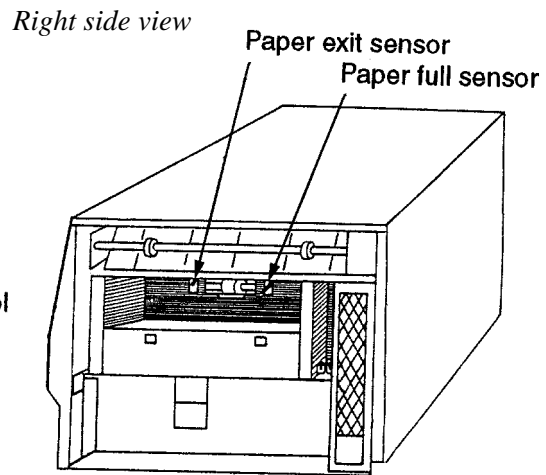
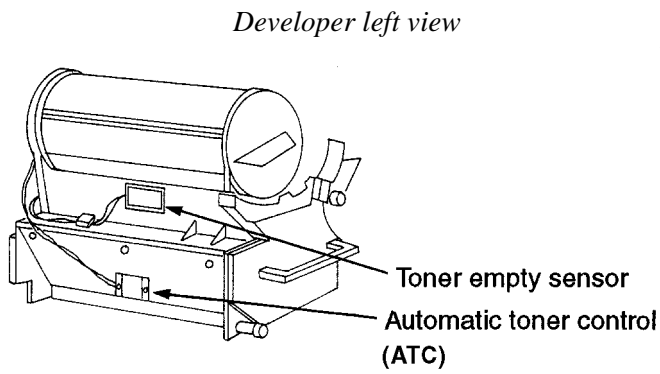
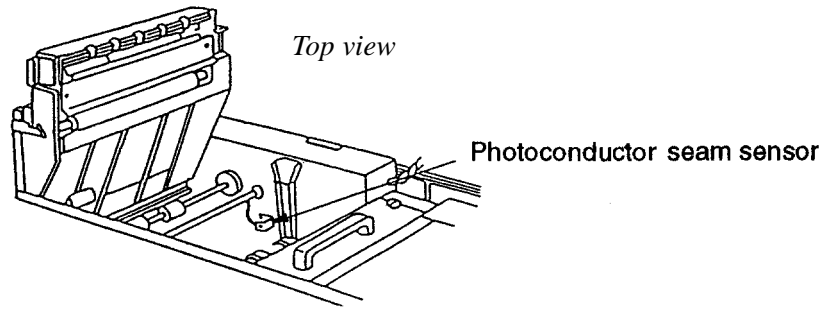

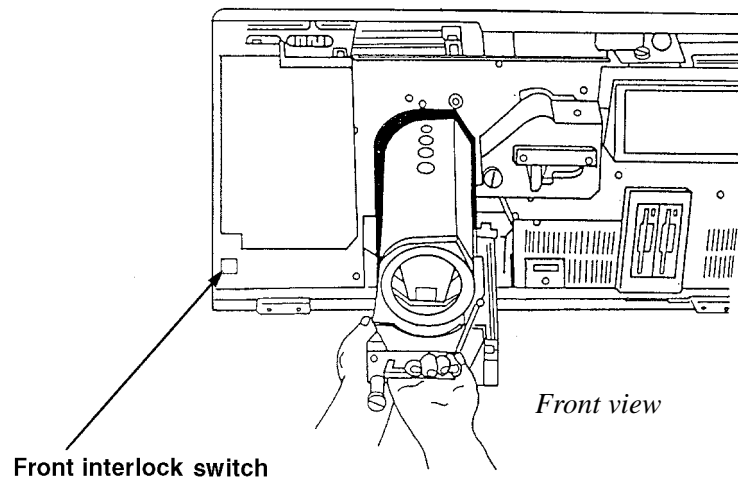

Troubleshooting

Throughout the printer's life problems occur, such as when it produces poor quality prints or malfunctions in another way. Use the tools provided in this manual to diagnose and resolve printer problems. These tools include:

- The Troubleshooting Analysis Guide, which contains troubleshooting procedures called TAGs. *TAG 001: Troubleshooting a Problem* explains how to use TAGs.
- Cross reference tables, which link error messages, print quality problems, and mechanical malfunctions to specific TAGs.
- Print quality samples, which help identify a printing problem and its associated TAGs.
- Diagnostics, which can uncover a range of problems.

The next several pages review troubleshooting basics and standard procedures followed in every troubleshooting session, including:

- Identifying whether a problem belongs to the printer or host
- Isolating protocol converter problems
- Running test prints
- Reading the error log
- Confirming line power
- Using TAGs
- Power-On Reset
- Installing the interlock by-pass tool
- Checking continuity
- Producing a developed image
- Producing a toner patch
- Completing a service call
- Clearing the error log

General Troubleshooting Tips

When a printer problem arises, swapping out all printer supplies may temporarily mask the problem. *This is an unsatisfactory, short-term, and expensive solution to correcting the problem.* Dust and other contamination, rather than printer supplies, are more often the causes of problems. Clean consumable connectors, alignment guides, and areas before changing consumables.

Many failures add excess toner to the printer's engine. When you are advised to de-tone the printer as part of a problem fix, run at least 200 test prints before deciding that the problem is resolved.

When you replace the photoconductor, run at least 500 prints before checking print quality. This number of prints is required to "synch" the new PC belt to the developer.

The Problem: Printer or Host?

The printer is one component in a large host system. Before you start any troubleshooting, make sure that the problem really belongs to the printer rather than to some other component in the host system. Print quality problems and mechanical malfunctions are almost always associated with the printer. However, host interface and software emulation problems can be caused by some other component of the host system even though, at first glance, they appear to be printer problems. For instance, text printed in the wrong location on a page, improper page breaks, and missing segments of data strongly indicate a host, not a printer, problem.

The first step in troubleshooting any problem is to isolate the printer from the host system; you can then run test prints. Producing test prints exercises the printer as a stand-alone machine, ensuring that the basic printer software and all mechanical functions of the printer are working.

Running Test Prints

- 1 Disconnect the host interface.
- 2 Make sure "Ready" displays on the panel.
- 3 Press **ONLINE**.
- 4 Press **MENU**
- 5 Press ∇ to highlight "Test Print"
- 6 Press \triangleright to select "Test Print"
- 7 Choose "Simplex" or "Duplex" (Duplex is the default. Press ∇ to choose simplex.)
- 8 Press \triangleright to start. A directory of the boot device and multiple listings of fonts prints. A continuous flow of the test pattern then prints.
- 9 To *stop* printing the test pattern, press \triangleleft . The printer will print all test prints stored in the printer's buffer, then stop.

If the test pattern prints successfully, the problem probably originates with the host system or a protocol converter connected to the host.

Protocol Converters

Many protocol converters have a self-test function or configuration mode that enables the user to check the proper functioning of the control. You can reconnect the host interface and ask the customer to exercise this function of the converter. If the printer receives data and prints it (even if the output is garbled) the problem may belong to the host or the protocol converter.

Reading the Error Log

The formatted error log is maintained by the printer in a file named "Error.log." You have the option to print this log when you are at the same panel used to print test prints. See "Running Test Prints" on page 1-12.

- The first section lists the numbers and text of the last 15 errors.
- The second section of the formatted log lists paper jams. A 3-digit error code (or codes) is followed by the error text and a 4-digit number indicating how many times the error has occurred since the error log was last cleared. (Clearing the error log is described on page 1-19.)
- The third section provides a complete error history since the error log was last cleared. Errors are listed in numeric order in the first column, with the number of times each error occurred listed in the second column.
- The fourth section indicates the last error that required a power-on-reset (POR).

Current Error Log

| LAST 15 RECORDED ERRORS | | OTHER ERROR INFORMATION CONT. | |
|-------------------------|-------|-------------------------------|-------|
| Code | Count | Code | Count |
| No Errors Found | | 305 | 0 |
| | | 306 | 0 |
| | | 307 | 0 |
| | | 380 | 0 |
| | | 381 | 0 |
| | | 382 | 0 |
| | | 383 | 0 |
| | | 384 | 0 |
| | | 385 | 0 |
| | | 386 | 0 |
| | | 387 | 0 |
| | | 389 | 0 |
| | | 397 | 0 |
| | | 399 | 0 |
| | | 401 | 0 |
| | | 405 | 0 |
| | | 406 | 0 |
| | | 407 | 0 |
| | | 408 | 0 |
| | | 409 | 0 |
| | | 500 | 0 |

| PAPER JAMS | | |
|------------|-------|----------------|
| Code | Count | Description |
| 020 | 0 | Upper Cassette |
| 021 | 0 | Lower Cassette |
| 022 | 0 | Transfer |
| 023 | 0 | At/Ne |
| 060 | 0 | |
| 061 | 0 | |
| 062 | 0 | |

Current Error Log P.2

| OTHER ERROR INFORMATION CONT. | | LAST FATAL ERROR RECORDED | |
|-------------------------------|-------|------------------------------------|-------|
| Code | Count | Code | Count |
| 605 | 0 | Last Error is NOT set in error log | |
| 606 | 0 | | |
| 702 | 0 | SOFTWARE ERROR SUBCODE | |
| 703 | 0 | For Reference ONLY: 0x0 | |
| 710 | 0 | | |
| 711 | 0 | | |

The error log is two pages long. This partial illustration shows the main components of the log.

Confirming Line Power

Erratic printer problems can be caused by improper line power. As a rule, the voltage of the outlet should be checked at installation. However, if you are unable to isolate an intermittent problem, the power should be checked again. Consult your country's national electric code for the proper procedures to check for acceptable voltages, as outlined on the following chart.

| Probe connections | 120v printer | 230v printer |
|--------------------------------------|---------------------|---------------------|
| red to AC hot black to AC neutral | 120v +/- 10% | 230v +/- 10% |
| red to AC neutral black to ground | 3 vac or less | 3 vac or less |
| red to AC hot black to ground | 120v +/- 10% | 230 +/- 10% |

Please see [Section 5, Diagnostic Tests](#), for additional information about troubleshooting specific printer problems.

Please see [Section 6, Wiring Diagrams and Electrical Data](#), for additional information about the printer's electrical systems.

Using the Troubleshooting Analysis Guide (TAG)

The Troubleshooting Analysis Guide provides problem-solving sequences to help you identify and resolve printer problems. Each TAG addresses a particular symptom or error message of the printer. The TAG number often matches an error message code displayed on the printer's operator panel.

| TAG Number | TAG Name | Sample TAG |
|--|---|---|
| ↓ | ↓ | |
| TAG 001: Troubleshooting a Problem | | |
| | Error Message: | All related error messages are listed here. |
| | Possible Causes: | All possible causes are listed here. |
| | Possible Defects: | All possible defective parts are listed here. (In no particular order.) |
| <hr/> | | |
| 1 Starting actions Yes/No Question To Do | To start: <ul style="list-style-type: none"> • Disconnect all peripheral cables • Power-on-reset the printer. Is an error message displayed? No: Run test prints, following the procedure outlined in Section 1, then repeat this step. If the answer is still no, refer to the mechanical malfunctions cross-reference chart in Section 2 to determine which TAG to follow. Then turn to that TAG. Yes: Note the error message and continue. | |
| <hr/> | | |
| 2 | Power-on-reset the printer. Did the power-on-reset end with an error message? No: Continue. Yes: Refer to the error message cross-reference table in Section 2, using either the code that displayed after steps 1 and 2, or if multiple error messages continue to appear, the first error message that displays. Turn to the TAG associated with the message. | |

Each TAG walks through a comprehensive procedure specific to a single problem. As you progress through a TAG and eliminate possible causes, you may be directed to another step out of sequence in the same TAG or to another TAG altogether.

The TAG number and its title may be followed by a listing of possible error messages, possible causes, or possible defective parts related to the TAG.

The TAG then directs you to perform certain tasks. Based on the results of these tasks, the TAG poses questions that can be answered by either yes or no. For yes answers, you follow one path; for no answers, follow another path. Some of the paths may lead you to other TAGs, so that you can methodically diagnose and resolve problems. When you have corrected a problem, you will be directed to TAG 002 to confirm that the problem has been completely resolved and standard cleanup procedures observed.

Troubleshooting

If it's not clear how to diagnose a problem you're working on, follow the steps outlined in TAG 001, which includes references to the cross reference tables contained in [Section 2, TAG Cross- Reference Tables](#). Or, you may turn directly to the tables to get started.

As you use TAGs, you will sometimes refer to other sections of this manual for additional information:

- [Section 4, Print Quality Samples](#), contains print quality samples you'll use to compare the customer's test prints with flawed and good print samples.
- [Section 5, Diagnostic Tests](#), outlines how to conduct printer diagnostic tests.
- [Section 6, Wiring Diagrams and Electrical Data](#), provides all wiring and connector diagrams.
- [Section 7, Removal/Replacement Procedures](#), provides step-by-step procedures for removing and replacing all field-replaceable parts on the printer.
- [Section 8, Options](#), reviews printer options (HCI, HCO) information.
- [Section 9, General Printer Maintenance](#), presents general printer maintenance procedures.

Standard Procedures

While using the TAGs, you may be asked to perform some of the following procedures. Specific instructions for completing these procedures are included here, rather than repeated in the body of each TAG. Please read this information before following any TAG.

Power-on-reset (POR)

When directed to power-on-reset the printer:

- 1 Turn off the printer.
- 2 Wait at least 5 seconds.
- 3 Turn the power back on.

Checking Continuity

! Make sure the printer is turned off and the power disconnected. Failure to do so may result in personal injury, equipment damage, or both.

To perform a continuity check:

- 1 Turn off the printer and disconnect the power cord.
- 2 Set your meter to the lowest ohm setting.
- 3 Interpret the results as follows:
 - An infinite reading indicates an open circuit.
 - A zero or specific reading indicates continuity.
- 4 To check an open or short circuit to ground:
 - Turn off the printer and disconnect the power cord.
 - Locate the circuit in question. (Refer to [Section 6, Wiring Diagrams and Electrical Data](#), for circuit locations.)
 - Check all connectors and wiring on each side for corrosion, foreign objects, bent pins, loose socket housings, and/or loose wires.

Installing the Interlock By-pass Tool

The interlock by-pass tool overrides the cover interlock switches, allowing you to operate the printer with the covers open. The interlock by-pass tool is a white plastic, V-shaped tool with two finger pads. To use the tool, open the cover and locate the interlock switch (for locations, see illustrations in “[Sensors and Switches Illustrations](#)” on page 1-8). Squeeze the tool between thumb and forefinger and insert it into the interlock switch.

The printer ships with two spare interlock by-pass tools concealed behind the right cover. Replace them when you are finished using them.

! Do not attempt to close the printer cover while the interlock by-pass tool is in place.

Producing a Developed Image

Producing a developed image helps determine where exactly in the print cycle a problem may be occurring. To produce a developed image:

- 1 Open the top cover and install an interlock by-pass tool.
 - 2 Power-on-reset the printer.
 - 3 Run a series of test prints. See [“Running Test Prints” on page 1-12.](#)
 - 4 As test patterns print, observe paper moving from the upper paper tray to the paper timing roller where it pauses briefly.
 - 5 As soon as a sheet of paper begins to move from the paper timing roller, remove the interlock by-pass tool.
 - 6 Remove the photoconductor.
 - 7 Examine the photoconductor belt to verify that a developed image was produced.
- ! Caution: Do not touch the surface of the photoconductor belt; this damages the belt and results in poor print quality.

Producing a Toner Patch

To produce a toner patch:

- 1 Turn off the printer.
- 2 Open the top cover and install an interlock by-pass tool.
- 3 Turn on the printer.
- 4 Start running test prints. When the leading edge of the first print enters the fuser, wait one second then remove the interlock by-pass tool.
- 5 Remove the photoconductor.

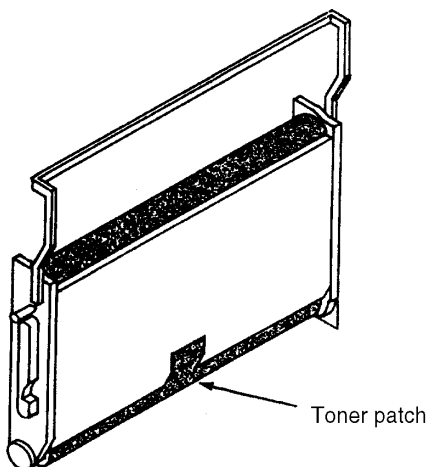

Producing a toner patch on the photoconductor.

- 6 Examine the photoconductor to verify that a toner patch has been produced. You may have to rotate the belt slightly to observe the patch.
- ! **Caution:** Do not touch the surface of the photoconductor belt; this damages the belt and results in poor print quality.

Completing a Service Call

After resolving any printer problem, complete the service call as follows:

- 1 Reassemble the printer.
- 2 Perform the every-call cleaning procedure, described in [Section 9, General Printer Maintenance](#).
- 3 Power-on-reset the printer.
- 4 Clear the error log. (See the procedure described next.)
- 5 Run test prints in both the simplex and duplex mode from both the upper and lower paper cassettes.
- 6 Fill in the Repair/Maintenance record taped inside the front cover. Make sure the problem description and steps taken to resolve the problem are clearly documented.

Clearing the Error Log

- 1 Enter the diagnostic mode of the printer:
 - Turn off the printer and wait 5 seconds.
 - Hold down the **MENU** and **STATUS** keys simultaneously as you turn the printer back on. Wait for all three LEDs to come on. This takes approximately 30 seconds.
- 2 Press ∇ to display the first available test.
- 3 Once a test name is displayed, use the ∇ key to move through the available tests.
- 4 Press the ∇ key until “Clear Error Log” shows on the display.
- 5 Press \triangleright to activate the procedure.
- 6 Press ∇ to advance to the drive where the error log is maintained. This is usually the boot drive.
- 7 Press ∇ to clear the error log on the selected drive.
- 8 Press \triangleleft to exit the procedure.
- 9 Confirm that the error log has been cleared.
- 10 Exit diagnostic mode (power-on reset)
- 11 Print the error log. All errors in all sections should be reset to zero.

Error Message and Code Technical Definitions

Error messages/codes are listed here alphanumerically. Sensor and switch locations referred to throughout these descriptions are illustrated on [page 1-8](#).

| Type | Message | Description |
|------------------------------|--|---|
| | MACHINE CHECK Unknown Error | 1. There is no text associated with the error. 2. The error is not included in the error look-up tables. |
| Paper Jams | PAPER JAM 020 Upper Cassette | AVPCL board detected that the paper being fed from the upper cassette did not reach the timing paper sensor within the allotted time. |
| | PAPER JAM 021 Lower Cassette | AVPCL board detected that the paper being fed from the lower cassette did not reach the timing paper sensor within the allotted time. |
| | PAPER JAM 022 Transfer/Fuser | AVPCL board detected that the timing paper sensor was activated immediately after one of the covers were closed or the leading edge of the paper did not activate the exit paper sensor within the allotted time. |
| | PAPER JAM 023 At/Near Exit | AVPCL board detected that the exit paper sensor in the printer (or in the HCO if installed) did not deactivate within the allotted time. |
| | PAPER JAM 024 At/Near HCO Exit | AVPCL board detected that the paper did not reach the HCO exit paper sensor within the allotted time. |
| | PAPER JAM 025 At/Near Input | AVPCL board detected that either the exit paper sensor (within the printer) or the paper exit sensor (within the HCO) were activated immediately after one of the covers was closed. |
| | PAPER JAM 026 At/Near Output | (HCO only). The paper exit sensor (within the HCO) did not become activated or deactivated within the allotted time. |
| | PAPER JAM 027 In Duplex Area | The AVPCL board detected paper in the duplex area after clearing a jam. |
| | PAPER JAM 060 Duplex Roller | AVPCL board detected that the leading edge of the paper did not activate the BC sensor within the allotted time. |
| | PAPER JAM 061 Duplex Path | AVPCL board detected that the trailing edge of the paper did not deactivate the BC sensor within the allotted time. |
| PAPER JAM 062 Duplex Tray | Paper picked from the registration tray did not reach the timing roller sensor within the allotted time. | |

Error Message and Code Technical Definitions

| Type | Message | Description |
|-----------------------------|--|---|
| Toner Control Errors | MACHINE CHECK TPS Too Low Error #031 | AVPCL board detected a signal from the toner patch sensor board indicating that the reference voltage level on the photoconductor was too low. |
| | MACHINE CHECK TPS Too Light Error #032 | AVPCL board detected a signal from the toner patch sensor board indicating that the toner patch on the photoconductor was too light. |
| | MACHINE CHECK TPS Signal Overload Error #033 | AVPCL board detected too many successive signals from the toner patch sensor board for a toner feed. |
| | MACHINE CHECK No Developer Error #036 | AVPCL board detected no developer electrical interlock signal from the J25 connector. |
| | MACHINE CHECK TPS Too High Error #037 | AVPCL board detected a signal from the toner patch sensor board indicating that the reference voltage level on the photoconductor was too high. |

Error Message and Code Technical Definitions

| Type | Message | Description |
|---------------------|--|--|
| OPC Rotation Errors | MACHINE CHECK No Signal from PSS Error #040 | AVPCL board sensed that the signal from the photoconductor seam sensor either was not of sufficient amplitude or did not show the proper timing. |
| | MACHINE CHECK PSS Sensor Shorted Error #041 | AVPCL board detected an abnormally high amount of current needed to drive the photoconductor seam sensor LED (within the photoconductor). |
| | MACHINE CHECK PSS Sensor Open Error #042 | AVPCL board detected an open connection to the photoconductor seam sensor LED (within the photoconductor). |
| | MACHINE CHECK AVPCL NVRAM Error #043 | AVPCL board non-volatile RAM error. |
| | MACHINE CHECK Charge Corona Open Error #044 | AVPCL board detected a signal from the high-voltage power supply indicating that either the charge corona or transfer corona circuits have an open connection. |
| | MACHINE CHECK Charge Corona Short Error #045 | AVPCL board detected a signal from the high-voltage power supply indicating an abnormally high load on the bias voltage to the charge corona. |
| | MACHINE CHECK PC Life Data Error Error #047 | AVPCL board received invalid life data from the photoconductor serializer board. |
| | MACHINE CHECK Developer Life Error Error #048 | AVPCL board received invalid life data received from the developer serializer board. |
| | MACHINE CHECK CRU Series Mismatch Error #049 | AVPCL board detected invalid data from either the photoconductor or developer units. Verify that the CRUs are correct for this printer. |
| HVPS Errors | MACHINE CHECK Transfer Corona Short Error #050 | AVPCL board detected a signal from the high-voltage power supply indicating an abnormally high load on the bias voltage to the transfer corona. |
| | MACHINE CHECK Transfer Corona Open Error #051 | AVPCL board detected a signal from the high-voltage power supply indicating an open connection in the transfer corona circuit. (Diagnostic test only.) |
| | MACHINE CHECK Eraser Lamp Error Error #055 | AVPCL board detected that the current needed to drive the erase lamp assembly was either higher or lower than the specified limits. (Diagnostic test only.) |
| | MACHINE CHECK Duplex not installed Error #069 | Duplex turnaround tray is not electrically connected to the printer. (Diagnostic test only.) |

Error Message and Code Technical Definitions

| Type | Message | Description |
|-----------------------------|---|--|
| Fuser Control Errors | MACHINE CHECK Fuser/Thermal Fuse Error #070 | AVPCL board sensed, via the fuser thermistor, that the temperature of the fuser did not change within the allotted time. |
| | MACHINE CHECK No Fuser/Thermistor Error #071 | AVPCL board sensed an open connection in the fuser thermistor circuit. |
| | MACHINE CHECK Fuser Temp Too High Error #072 | AVPCL board sensed that the resistance of the fuser thermistor was too low indicating that the temperature of the fuser was higher than the specified limit. |
| | MACHINE CHECK Fuser Temp Too Low Error #073 | AVPCL board sensed that the resistance of the fuser thermistor was too high indicating that the temperature of the fuser was lower than the specified limit. |
| Jogger Errors | MACHINE CHECK Duplex Registration Error #086 | AVPCL board detected a signal from the duplex control board #2 indicating that either the registration side sensor was activated and would not deactivate or was deactivated and would not activate after a command was sent to the duplex control board #2 to turn on the resist motor. |
| LVPS Errors | MACHINE CHECK Bad PC Type Error #091 | AVPCL board detected that the photoconductor is installed improperly, or is of the wrong type. Verify that the photoconductor is the correct type for the printer. |
| | MACHINE CHECK Bad Dev Type Error #092 | AVPCL board detected that the developer is installed improperly, or is of the wrong type. Verify that the developer is the correct type for the printer. |
| | MACHINE CHECK +12 DC Power Failure Error #097 | AVPCL board detected a signal from the RIGS board indicating the absence of +12 Vdc. |
| | MACHINE CHECK +24 DC Power Failure Error #099 | AVPCL board detected a signal from the RIGS board indicating the absence of +24 Vdc. |
| AVPCL Error | MACHINE CHECK IML Error Error #130 | RIGS board detected an error when attempting to download information to the AVPCL flash EPROM. |
| | MACHINE CHECK Bad AVPCL ROM Checksum Error #140 | RIGS board detected an error from the AVPCL board during initial AVPCL diagnostic. |
| | MACHINE CHECK AVPCL PIA1 Reset Fail Error #160 | RIGS board detected an error from the AVPCL board during initial AVPCL diagnostic. |
| | MACHINE CHECK AVPCL PIA1 R/W at POR Error #161 | RIGS board detected an error from the AVPCL board during initial AVPCL diagnostic. |

Error Message and Code Technical Definitions

| Type | Message | Description |
|----------------------|---|---|
| AVPCL Errors (cont.) | MACHINE CHECK AVPCL PIA1 Reset Fail Error #170 | RIGS board detected an error from the AVPCL board during initial AVPCL diagnostic. |
| | MACHINE CHECK AVPCL PIA1 R/W at POR Error #171 | RIGS board detected an error from the AVPCL board during initial AVPCL diagnostic. |
| | MACHINE CHECK AVPCL PTM Reset Fail Error #180 | RIGS board detected an error from the AVPCL board during initial AVPCL diagnostic. |
| | MACHINE CHECK AVPCL PTM Read/Write Error #181 | RIGS board detected an error from the AVPCL board during initial AVPCL diagnostic. |
| | MACHINE CHECK AVPCL PTM IRQ Failure Error #182 | RIGS board detected an error from the AVPCL board during initial AVPCL diagnostic. |
| | MACHINE CHECK I ² C Oppanel Fatal Error #260 | RIGS board detected a fatal error from the AVPCL board during initial AVPCL diagnostic. |
| | MACHINE CHECK I ² C Oppanel Warning Error #261 | RIGS board detected an error from the AVPCL board during initial AVPCL diagnostic. |
| | MACHINE CHECK Transmit Failed Error #270 | RIGS board detected transmit failed, lost arbitration, with the control panel. |
| | MACHINE CHECK Transmit Failed Error #271 | RIGS board detected transmit failed, no acknowledgment, with the control panel. |
| | MACHINE CHECK Transmit Failed Error #272 | RIGS board detected transmit failed, bus always busy, with the control panel. |
| | MACHINE CHECK Transmit Error Error #273 | RIGS board detected a transmit error on the I ² C bus, with the control panel. |
| | MACHINE CHECK Error #274 | RIGS board detected I ² C host not ready. |

Error Message and Code Technical Definitions

| Type | Message | Description |
|-----------------------------|---|--|
| AVPCL Errors (cont.) | MACHINE CHECK Error #275 | RIGS board detected receiver overruns. |
| | MACHINE CHECK Error #276 | RIGS board detected a framing error on receive. |
| | MACHINE CHECK Error #277 | RIGS board detected a receive overflow. |
| | MACHINE CHECK Error #278 | Control panel has failed to establish communication with the RIGS board. Verify the cabling between the control panel, the RIGS board, and the AVCPL boards. |
| | MACHINE CHECK Error #280 | Control panel has lost communication with the RIGS board. Verify the cabling between the control panel, the RIGS board, and the AVCPL boards |
| | MACHINE CHECK Error #281 | Invalid command sent to the operator panel. |
| | MACHINE CHECK AVPCL No Data VSS High Error #301 | RIGS board detected an error from the AVPCL board during initial AVPCL diagnostic. |
| | MACHINE CHECK AVPCL TS High VSS Low Error #302 | RIGS board detected an error from the AVPCL board during initial AVPCL diagnostic. |
| | MACHINE CHECK TC High but not VSC Error #303 | RIGS board detected an error from the AVPCL board during initial AVPCL diagnostic. |
| | MACHINE CHECK VSC high too long Error #304 | RIGS board detected an error from the AVPCL board during initial AVPCL diagnostic. |
| | MACHINE CHECK AVPCL VSC Invalid Error #305 | RIGS board detected an error from the AVPCL board during initial AVPCL diagnostic. |
| | MACHINE CHECK TS high and data xfr Error #306 | RIGS board detected an error from the AVPCL board during initial AVPCL diagnostic. |
| | MACHINE CHECK AVPCL Parity Error Error #307 | RIGS board detected an error from the AVPCL board during initial AVPCL diagnostic. |

Error Message and Code Technical Definitions

| Type | Message | Description |
|--------------------------|---|--|
| Controller Errors | MACHINE CHECK PCL Cmd Retry Error Error #380 | RIGS board detected an error during the internal diagnostic testing of the RIGS board. |
| | MACHINE CHECK PCL Cmd Rejected Error #381 | RIGS board detected an error during the internal diagnostic testing of the RIGS board. |
| | MACHINE CHECK PCL Sent Bad Cmd Error #382 | RIGS board detected an error during the internal diagnostic testing of the RIGS board. |
| | MACHINE CHECK PCL Sent Bad Byte Error #383 | RIGS board detected an error during the internal diagnostic testing of the RIGS board. |
| | MACHINE CHECK PCL Got TS-No Status Error #384 | RIGS board detected an error during the internal diagnostic testing of the RIGS board. |
| | MACHINE CHECK PCL SIB/Count Bad Error #385 | RIGS board detected an error during the internal diagnostic testing of the RIGS board. |
| | MACHINE CHECK PCL Bad SIB Offset Error #386 | RIGS board detected an error during the internal diagnostic testing of the RIGS board. |
| | MACHINE CHECK PCL Parity Error Error #387 | RIGS board detected an error during the internal diagnostic testing of the RIGS board. |
| | MACHINE CHECK Unknown Error Error #397 | RIGS board detected an internal software error. |

Error Message and Code Technical Definitions

| Type | Message | Description |
|----------------------------------|---|---|
| Controller Errors (cont.) | MACHINE CHECK Fatal Software Error Error #398 | RIGS board detected an internal software error. |
| | MACHINE CHECK Software Error Error #399 | RIGS board detected an internal software error. |
| | MACHINE CHECK Peripheral Bus Error Error #401 | RIGS board detected an error during the internal diagnostic testing of the peripheral bus. |
| | MACHINE CHECK RAM Bank Selection Error #405 | RIGS board detected an error in the program RAM during the internal diagnostic testing of the RIGS board. |
| | MACHINE CHECK RAM Bank 0 Address Error #406 | RIGS board detected an error in the program RAM during the internal diagnostic testing of the RIGS board. |
| | MACHINE CHECK RAM Bank 0 Refresh Error #407 | RIGS board detected an error in the program RAM during the internal diagnostic testing of the RIGS board. |
| | MACHINE CHECK RAM Bank 1 Address Error #408 | RIGS board detected an error in the program RAM during the internal diagnostic testing of the RIGS board. |
| | MACHINE CHECK RAM Bank 1 Refresh Error #409 | RIGS board detected an error in the program RAM during the internal diagnostic testing of the RIGS board. |
| Disk Drive Errors | MACHINE CHECK Incorrect Diskette Error #450 | RIGS board detected an error during the internal diagnostic testing of the RIGS board and software. |
| | MACHINE CHECK Floppy Format Error Error #451 | RIGS board detected an error during the internal diagnostic testing of the RIGS board and software. |
| Controller Errors | MACHINE CHECK Fatal Software Trap Error #454 | RIGS board detected an error during the internal diagnostic testing of the RIGS board and software. |
| | MACHINE CHECK Software Trap Error #455 | RIGS board detected an error during the internal diagnostic testing of the RIGS board and software. |
| | MACHINE CHECK PIT0 Invalid Error #500 | RIGS board detected an error during the internal diagnostic testing of the RIGS board and software. |

Error Message and Code Technical Definitions

| Type | Message | Description |
|----------------------------------|--|---|
| Controller Errors (cont.) | MACHINE CHECK PIT0 Read/Write Error Error #501 | RIGS board detected an error during the internal diagnostic testing of the RIGS board and software. |
| | MACHINE CHECK PIT0 No Countdown Error #502 | RIGS board detected an error during the internal diagnostic testing of the RIGS board and software. |
| | MACHINE CHECK PIT0 No Timer Halt Error #503 | RIGS board detected an error during the internal diagnostic testing of the RIGS board and software. |
| | MACHINE CHECK PIT0 No Timer Intr Error #504 | RIGS board detected an error during the internal diagnostic testing of the RIGS board and software. |
| | MACHINE CHECK PIT2 Invalid Error #505 | RIGS board detected an error during the internal diagnostic testing of the RIGS board and software. |
| | MACHINE CHECK PIT2 Read/Write Err. Error #506 | RIGS board detected an error during the internal diagnostic testing of the RIGS board and software. |
| | MACHINE CHECK PIT2 No Countdown Error #507 | RIGS board detected an error during the internal diagnostic testing of the RIGS board and software. |
| | MACHINE CHECK PIT2 No Timer Halt Error #508 | RIGS board detected an error during the internal diagnostic testing of the RIGS board and software. |
| | MACHINE CHECK PIT2 No Timer Intr Error #509 | RIGS board detected an error during the internal diagnostic testing of the RIGS board and software. |
| | MACHINE CHECK No DMAC Reset Error #520 | RIGS board detected an error during the internal diagnostic testing of the RIGS board and software. |
| | MACHINE CHECK DMAC Read/Write Error #521 | RIGS board detected an error during the internal diagnostic testing of the RIGS board and software. |
| | MACHINE CHECK No DMA Transfer Error #522 | RIGS board detected an error during the internal diagnostic testing of the RIGS board and software. |
| | MACHINE CHECK No DMA Transfer End Error #523 | RIGS board detected an error during the internal diagnostic testing of the RIGS board and software. |

Error Message and Code Technical Definitions

| Type | Message | Description |
|----------------------------------|---|---|
| Controller Errors (cont.) | MACHINE CHECK No End DMA Interrupt Error #524 | RIGS board detected an error during the internal diagnostic testing of the RIGS board and software. |
| | MACHINE CHECK DMA Software Abort Error #525 | RIGS board detected an error during the internal diagnostic testing of the RIGS board and software. |
| | MACHINE CHECK DMA Software Intr. Error #526 | RIGS board detected an error during the internal diagnostic testing of the RIGS board and software. |
| | MACHINE CHECK DMA Operation Error Error #527 | RIGS board detected an error during the internal diagnostic testing of the RIGS board and software. |
| | MACHINE CHECK DMA Transfer Error Error #528 | RIGS board detected an error during the internal diagnostic testing of the RIGS board and software. |
| | MACHINE CHECK DMAC2 Transfer Error Error #529 | RIGS board detected an error during the internal diagnostic testing of the RIGS board and software. |
| | MACHINE CHECK No DMAC2 Transfer Error #530 | RIGS board detected an error during the internal diagnostic testing of the RIGS board and software. |
| | MACHINE CHECK AVPCL SCC register R/W Error #540 | RIGS board detected an error during the internal diagnostic testing of the RIGS SCC UART. |
| | MACHINE CHECK AVPCL break detected Error #541 | RIGS board detected an error during the internal diagnostic testing of the RIGS SCC UART. |
| | MACHINE CHECK AVPCL SCC xmit not Error #542 | RIGS board detected an error during the internal diagnostic testing of the RIGS SCC UART. |
| | MACHINE CHECK No AVPCL SCC Transfer Error #543 | RIGS board detected an error during the internal diagnostic testing of the RIGS SCC UART. |
| | MACHINE CHECK AVPCL SCC Transfer Error #544 | RIGS board detected an error during the internal diagnostic testing of the RIGS SCC UART. |
| | MACHINE CHECK Host SCC R/W Error #545 | RIGS board detected an error during the internal diagnostic testing of the RIGS SCC UART. |

Error Message and Code Technical Definitions

| Type | Message | Description |
|----------------------------------|---|---|
| Controller Errors (cont.) | MACHINE CHECK Host xmit not ready Error #546 | RIGS board detected an error during the internal diagnostic testing of the RIGS SCC UART. |
| | MACHINE CHECK No TX/RX interrupt Error #547 | RIGS board detected an error during the internal diagnostic testing of the RIGS SCC UART. |
| | MACHINE CHECK SCC HOST/AVPCL Parity Error #548 | RIGS board detected an error during the internal diagnostic testing of the RIGS SCC UART. |
| | MACHINE CHECK SCC unexpected Intr. Error #549 | RIGS board detected an error during the internal diagnostic testing of the RIGS SCC UART. |
| | MACHINE CHECK SCC Transmission Error #550 | RIGS board detected an error during the internal diagnostic testing of the RIGS board and software. |
| | MACHINE CHECK No AVPCL SCC Interrupt Error #551 | RIGS board detected an error during the internal diagnostic testing of the RIGS board and software. |
| | MACHINE CHECK SCC-DMAC Interaction Error #552 | RIGS board detected an error during the internal diagnostic testing of the RIGS board and software. |
| | MACHINE CHECK SCC-DMAC Transfer # Error #553 | RIGS board detected an error during the internal diagnostic testing of the RIGS board and software. |
| | MACHINE CHECK SCC-DMAC Transfer Error #554 | RIGS board detected an error during the internal diagnostic testing of the RIGS board and software. |
| | MACHINE CHECK RS232 Send/Rcv Error #555 | RIGS board detected an error during the internal diagnostic testing of the RIGS board and software. |
| | MACHINE CHECK RS232 DTR/DCD Error #556 | RIGS board detected an error during the internal diagnostic testing of the RIGS board and software. |
| | MACHINE CHECK RS232 RTS/CTS Error #557 | RIGS board detected an error during the internal diagnostic testing of the RIGS board and software. |
| | MACHINE CHECK RS422 Send/Rcv Error #558 | RIGS board detected an error during the internal diagnostic testing of the RIGS board and software. |

Error Message and Code Technical Definitions

| Type | Message | Description |
|----------------------------------|---|---|
| Controller Errors (cont.) | MACHINE CHECK RS422 Send/Rcv Clock Error #559 | RIGS board detected an error during the internal diagnostic testing of the RIGS board and software. |
| | MACHINE CHECK CRTC Read/Write Error #560 | RIGS board detected an error during the internal diagnostic testing of the RIGS board and software. |
| | MACHINE CHECK No Page Begin Intr. Error #561 | RIGS board detected an error during the internal diagnostic testing of the RIGS board and software. |
| | MACHINE CHECK CRTC Address Error #562 | RIGS board detected an error during the internal diagnostic testing of the RIGS board and software. |
| | MACHINE CHECK No VSYNC Generation Error #563 | RIGS board detected an error during the internal diagnostic testing of the RIGS board and software. |
| | MACHINE CHECK No End of Page Intr. Error #564 | RIGS board detected an error during the internal diagnostic testing of the RIGS board and software. |
| | MACHINE CHECK No CRTC Termination Error #565 | RIGS board detected an error during the internal diagnostic testing of the RIGS board and software. |
| | MACHINE CHECK VSYNC Timeout Error Error #566 | RIGS board detected an error during the internal diagnostic testing of the RIGS board and software. |
| Disk Drive Errors | MACHINE CHECK FDC/SCSI Read/Write Error #570 | RIGS board detected an error when communicating with the floppy disk drive. |
| | MACHINE CHECK FDC Busy Timeout Error #571 | RIGS board detected an error when communicating with the floppy disk drive. |
| | MACHINE CHECK Write Protected Error #572 | RIGS board detected an error when communicating with the floppy disk drive. |
| | MACHINE CHECK Floppy Not Ready Error #573 | RIGS board detected an error when communicating with the floppy disk drive. |
| | MACHINE CHECK FDC Restore Error Error #574 | RIGS board detected an error when communicating with the floppy disk drive. |

Error Message and Code Technical Definitions

| Type | Message | Description |
|----------------------------------|--|---|
| Disk Drive Errors (cont.) | MACHINE CHECK FDC Seek Error Error #575 | RIGS board detected an error when communicating with the floppy disk drive. |
| | MACHINE CHECK FDC Read Error Error #576 | RIGS board detected an error when communicating with the floppy disk drive. |
| | MACHINE CHECK FDC Checksum Error Error #577 | RIGS board detected an error when communicating with the floppy disk drive. |
| | MACHINE CHECK FDC Write Error Error #578 | RIGS board detected an error when communicating with the floppy disk drive. |
| | MACHINE CHECK FDC R-M-W-V Error Error #579 | RIGS board detected an error when communicating with the floppy disk drive. |
| | MACHINE CHECK FDC/PIT0 Interrupt Error #580 | RIGS board detected an error when communicating with the floppy disk drive. |
| | MACHINE CHECK FDC/DMA Interaction Error #581 | RIGS board detected an error when communicating with the floppy disk drive. |
| | MACHINE CHECK FDC/DMAC Transfer Error #582 | RIGS board detected an error when communicating with the floppy disk drive. |
| | MACHINE CHECK FDC/DMAC Transfer # Error #583 | RIGS board detected an error when communicating with the floppy disk drive. |
| | MACHINE CHECK FDC/DMAC Read Error #584 | RIGS board detected an error when communicating with the floppy disk drive. |
| | MACHINE CHECK FDC/DMAC Write Error #585 | RIGS board detected an error when communicating with the floppy disk drive. |
| | MACHINE CHECK FDC/DMAC Operations Error #586 | RIGS board detected an error when communicating with the floppy disk drive. |

Error Message and Code Technical Definitions

| Type | Message | Description |
|--------------------------|--|--|
| Controller Errors | MACHINE CHECK Bit Map RAM Data Error #600 | RIGS board detected an error during internal testing. |
| | MACHINE CHECK Bit Map RAM Bank Error #601 | RIGS board detected an error during internal testing. |
| | MACHINE CHECK Bit Map RAM Refresh Error #602 | RIGS board detected an error during internal testing. |
| | MACHINE CHECK Bit Map RAM Address Error #603 | RIGS board detected an error during internal testing. |
| | MACHINE CHECK ALU Op in Bit RAM Error #604 | RIGS board detected an error during internal testing. |
| | MACHINE CHECK Width/Origin Fault Error #605 | RIGS board detected an error during internal testing. |
| | MACHINE CHECK BMRAM Bank Fault Error #606 | RIGS board detected an error during internal testing. |
| Interface Errors | MACHINE CHECK Host SCC Error Error #701–#708 | RIGS board detected an error when communicating with a host using serial communications on the ASYNC flex IO card. |
| Controller Error | MACHINE CHECK Host SCC Error Error #709 | RAM test failure during power-on diagnostics. |
| Interface Errors | MACHINE CHECK Host SCC Error Error #710–#722 | RIGS board detected an error when communicating with a host using serial communications on the ASYNC flex IO card. |
| | MACHINE CHECK Parallel Error Error #725–#741 | RIGS board detected an error when communicating with a host using parallel communications on the ASYNC flex IO card. |
| | MACHINE CHECK Smart flex IO Card Error Error #745–#784 | RIGS board detected an error when communicating with a host using an intelligent flex IO card. |

Error Message and Code Technical Definitions

TAG Cross- Reference Tables

TAG Cross-Reference Tables

This section contains the three cross reference charts for troubleshooting print problems:

- [Error Code/TAG Cross-Reference](#)
- [Print Quality/TAG Cross-Reference](#)
- [Mechanical Malfunction/TAG Cross-Reference](#)

Error Code/TAG Cross-Reference

Error codes, which display on the operator's panel, indicate a wide variety of printer problems related to the control boards, software, and/or host communication problems. On the chart find the error code in question, then turn to TAG associated with the code.

| Code | Printer Error Code Meaning | Go to TAG |
|------|---|-----------|
| 010 | Upper paper tray out of paper | 010 |
| 011 | Lower paper tray out of paper | 011 |
| 012 | Upper paper tray not plugged in | 012 |
| 013 | Lower paper tray not plugged in | 013 |
| 020 | Upper paper tray paper jam | 020 |
| 021 | Lower paper tray paper jam | 021 |
| 022 | Transfer or fuser area paper jam | 022 |
| 023 | Exit area paper jam | 023 |
| 024 | Paper jam at/near HCO exit | 023 |
| 025 | Transfer or fuser area paper jam not cleared | 025 |
| 026 | Exit area paper jam not cleared | 026 |
| 027 | Duplex area paper jam | 902 |
| 030 | Developer bias short | 030 |
| 031 | Toner patch sensor reference level too low | 031 |
| 032 | Toner patch sensor black patch too light | 032 |
| 033 | Toner patch sensor overload | 032 |
| 035 | Toner empty error | 035 |
| 036 | No developer | 036 |
| 037 | Toner patch sensor too high | 031 |
| 040 | Photoconductor seam sensor malfunction | 040 |
| 041 | Photoconductor seam sensor short | 040 |
| 042 | Photoconductor seam sensor open | 040 |
| 044 | Charge/transfer corona open | 044 |
| 045 | Charge corona short | 045 |
| 047 | PC life error. Bad PC CRU information | 047 |
| 048 | Developer life error. Bad developer CRU information | 048 |
| 050 | Transfer corona short | 050 |

Error Code/TAG Cross-Reference

| Code | Printer Error Code Meaning | Go to TAG |
|------|---|-----------|
| 055 | Eraser lamp malfunction | 055 |
| 057 | Fan stopped sensor | 752 |
| 060 | Duplex area 1 paper jam | 902 |
| 061 | Duplex area 2 paper jam | 902 |
| 062 | Duplex area 3 paper jam | 902 |
| 069 | Duplex tray not plugged in | 900 |
| 070 | Fuser lamp or thermal fuse malfunction | 070 |
| 071 | Fuser thermistor open or no fuser | 071 |
| 072 | Fuser temperature too high | 072 |
| 073 | Fuser temperature too low | 070 |
| 081 | No front job offset sensor | 083 |
| 082 | No back job offset sensor | 083 |
| 083 | Job offset mechanism malfunction | 083 |
| 084 | Duplex tray registration sensor not activated | 901 |
| 085 | Duplex tray registration sensor not deactivated | 901 |
| 086 | Duplex registration tray malfunction | 901 |
| 090 | Cover open | 900 |
| 097 | DC +12v power failure | 097 |
| 098 | DC -12v power failure | 098 |
| 099 | DC +24v power failure | 099 |
| 100 | VPCL board command timeout | 100 |

| Code | VPCL/RIGS Communication Error Codes | Go to TAG |
|------|--|-----------|
| 121 | No controller command; VPCL board VSC command asserted | 201 |
| 122 | Command tag asserted; VSC command not asserted | 201 |
| 123 | VSS not asserted; VPCL board status tag asserted | 201 |
| 124 | VSS asserted after VPCL board sent status | 201 |
| 125 | VSS not asserted again though VPCL board expects it | 201 |
| 126 | Command tag asserted during data byte sequence | 201 |
| 127 | VPCL board detected parity/overrun on command line | 201 |

Error Code/TAG Cross-Reference

| Code | VPCL Error Codes | Go to TAG |
|-------------|--|------------------|
| 130 | Address or length error at initial microcode load | 130 |
| 131 | Checksum error at initial microcode load | 130 |
| 132 | RAM error at initial microcode load | 100 |
| 133 | No next block at initial microcode load | 130 |
| 134 | Incorrect format in initial microcode load file | 130 |
| 140 | VPCL board ROM checksum error at power on diagnostic | 100 |
| 145 | VPCL board RAM error at power on diagnostic | 100 |
| 160 | VPCL board PIA1 register error after reset | 100 |
| 161 | VPCL board PIA1 registers read/write error | 100 |
| 162 | VPCL board PIA1 PA or PB read/write error | 100 |
| 170 | VPCL board PIA2 register error after reset | 100 |
| 171 | VPCL board PIA2 register read/write error | 100 |
| 172 | VPCL board PIA2 PB read/write error | 100 |
| 180 | VPCL board PTM register error after reset | 100 |
| 181 | VPCL board PTM read/write error | 100 |
| 182 | No IRQ generation on PTM | 100 |

| Code | VPCL/RIGS Communication Error Codes | Go to TAG |
|-------------|---|------------------|
| 199 | VSS not asserted before communication test | 201 |
| 200 | Status tag not asserted | 201 |
| 201 | Timeout waiting for a failed RIGS controller | 201 |
| 202 | No data received after VSS line asserted | 201 |
| 203 | VSS asserted after VPCL board sent status | 201 |
| 204 | Status tag asserted after VSS not asserted | 201 |
| 205 | No command tag after status tag not asserted | 201 |
| 206 | VSC command not asserted after command tag asserted | 201 |
| 207 | No data received after VSC asserted | 201 |
| 208 | VSC command asserted after command line asserted | 201 |
| 209 | Command tag asserted after VSC not asserted | 201 |

Error Code/TAG Cross-Reference

| Code | VPCL/RIGS Communication Error Codes | Go to TAG |
|------|--|-----------|
| 210 | No RQI after "request RQI" command | 201 |
| 211 | Parity error on command line | 201 |
| 212 | Parity or overrun sensed by VPCL board | 201 |
| 213 | Incorrect command received from VPCL board | 201 |
| 214 | Incorrect command received from RIGS controller | 201 |
| 215 | No transfer buffer empty on asynchronous communications interface adapter after VPCL board sent data | 201 |

| Code | RIGS Firmware Error Codes | Go to TAG |
|------|---|-----------|
| | These error codes signal a problem with the RIGS controller firmware. No TAGs address these problems; report to Hewlett-Packard. | |
| 301 | Status received after VSS asserted | No TAG |
| 302 | Status tag asserted after VSS not asserted | No TAG |
| 303 | VSC command not asserted after command tag asserted | No TAG |
| 304 | VSC command asserted after data was sent | No TAG |
| 305 | VSC command not asserted for next data byte | No TAG |
| 306 | Status tag asserted while data was being sent | No TAG |
| 307 | Parity error on command line | No TAG |

| Code | VPCL Failure Error Codes | Go to TAG |
|------|--|-----------|
| 380 | VPCL board failure – command retries | 201 |
| 381 | VPCL board failure – command rejected | 201 |
| 382 | VPCL board failure – bad command received | 201 |
| 383 | VPCL board failure – unexpected byte received | 201 |
| 384 | VPCL board failure – no status received | 201 |
| 385 | VPCL board failure – bad status information block count | 201 |
| 386 | VPCL board failure – bad status information block offset | 201 |
| 387 | VPCL board failure – parity error | 201 |
| 389 | Floppy disk retry | 130 |

Error Code/TAG Cross-Reference

| Codes | RIGS Software Code Meaning These error codes indicate a problem with the RIGS controller software. No TAGs address these problems; to determine whether the faulty software is the customer's or the manufacturer's, contact Hewlett-Packard. | Go to TAG |
|--------------|---|------------------|
| 397 | RIGS software trap | No TAG |
| 398 | RIGS software trap | No TAG |
| 399 | RIGS software trap | No TAG |

| Codes | RIGS/Disk Drive Error Codes | Go to TAG |
|--------------|---|------------------|
| 401 | Fatal RIGS PB error | No TAG |
| 405 | RIGS RAM error | 201 |
| 406 | RIGS RAM error | 201 |
| 407 | RIGS RAM error | 201 |
| 408 | RIGS RAM error | 201 |
| 409 | RIGS RAM error | 201 |
| 450 | Incorrect diskette | 130 |
| 451 | Diskette format error or incorrect disk | 130 |
| 454 | Fatal trap | 200 |
| 455 | Trap | 200 |
| 500 | Incorrect PIT0 registers contents; no reset | 200 |
| 501 | PIT0 register read/write error | 200 |
| 502 | No countdown/zero detection in PIT0 timer | 200 |
| 503 | PIT0 timer; no halt | 200 |
| 504 | No PIT0 timer interrupt | 200 |
| 505 | Incorrect PIT2 registers contents; no reset | 200 |
| 506 | PIT2 register read/write error | 200 |
| 507 | No countdown/zero detection in PIT2 timer | 200 |
| 508 | PIT2 timer; no halt | 200 |
| 509 | No PIT2/timer interrupt | 200 |
| 520 | No DMAC reset | 200 |
| 521 | DMAC registers read/write error | 200 |

Error Code/TAG Cross-Reference

| Codes | RIGS/Disk Drive Error Codes | Go to TAG |
|-------|---|-----------|
| 522 | No DMA transfer | 200 |
| 523 | No DMA transfer termination | 200 |
| 524 | No DMAC termination interrupt | 200 |
| 525 | No software abort operation | 200 |
| 526 | No software abort interrupt | 200 |
| 527 | DMAC operation error | 200 |
| 528 | DMA transfer error | 200 |
| 529 | Two-channel DMA transfer error | 200 |
| 530 | No two-channel DMA transfer | 200 |
| 540 | VPCL board serial controller registers read/write error | 200 |
| 541 | VPCL board break condition detected | 200 |
| 542 | VPCL board serial controller transmitter not ready | 200 |
| 543 | No VPCL board serial controller transfer | 200 |
| 544 | VPCL board serial controller transfer error | 200 |
| 545 | Host serial controller registers read/write error | 200 |
| 546 | Host transmitter not ready | 200 |
| 547 | No serial controller interrupts | 200 |
| 548 | Host serial controller/VPCL board parity error | 200 |
| 549 | Serial controller unexpected interrupt | 200 |
| 550 | Two-channel transfer error | 200 |
| 551 | No VPCL board/serial controller interrupt on break | 200 |
| 552 | No serial controller/DMAC interaction | 200 |
| 553 | Serial controller/DMAC transfer count error | 200 |
| 554 | Serial controller/DMAC transfer error | 200 |
| 555 | RS232 send/receive path error | 200 |
| 556 | RS232 DTR/DTC path error | 200 |
| 557 | RS232 RTS/CTS path error | 200 |
| 558 | RS422 send/receive path error | 200 |
| 559 | RS422 send clock/receive clock path error | 200 |
| 560 | CRTC register read/write error | 200 |
| 561 | No page begin (PIT2) interrupt | 200 |

Error Code/TAG Cross-Reference

| Codes | RIGS/Disk Drive Error Codes | Go to TAG |
|--------------|--|------------------|
| 562 | No CRTIC address generation | 200 |
| 563 | No VSYNC generation (end of page) | 200 |
| 564 | No end of page (PIT2) interrupt | 200 |
| 565 | No CRTIC count termination | 200 |
| 566 | VSYNC timeout error | 200 |
| 570 | Drive controller/SCSI read/write error | 200 |
| 571 | Drive controller busy timeout | 200 |
| 572 | Diskette is write protected | 130 |
| 573 | Drive not ready | 130 |
| 574 | Drive controller restore error | 130 |
| 575 | Drive controller seek error | 130 |
| 576 | Drive controller read sector error | 130 |
| 577 | Drive controller read sector data/checksum error | 200 |
| 578 | Drive controller write sector error | 200 |
| 579 | Drive controller read/modify/write error | 200 |
| 580 | No drive controller/PIT0 interrupt | 200 |
| 581 | No drive controller-DMA interaction | 200 |
| 582 | Drive controller/DMAC transfer error | 200 |
| 583 | Drive controller/DMAC transfer count error | 200 |
| 584 | Drive controller/DMAC read sector error | 200 |
| 585 | Drive controller/DMAC write sector error | 200 |
| 586 | Drive hard error | 130 |

| Code | Bit Map RAM Error Codes | Go to TAG |
|-------------|--|------------------|
| 600 | Bit-map RAM data path error | 200 |
| 601 | Bit-map RAM bank selection error | 200 |
| 602 | Bit-map RAM refresh error | 200 |
| 603 | Bit-map RAM address path error | 200 |
| 604 | Incorrect ALU operation in bit-map RAM data path | 200 |
| 605 | Incorrect origin data modifications | 200 |

Error Code/TAG Cross-Reference

| Code | Bit Map RAM Error Codes | Go to TAG |
|-------------|--------------------------------|------------------|
| 606 | Total bit-map RAM bank fault | 405 |
| 610 | Bit-map RAM chip error | 405 |

| Code | Host Communication Error codes | Go to TAG |
|-------------|---------------------------------------|------------------|
| 701–741 | Async flex IO error | 753 |
| 745–755 | Smart flex IO error | 754 |

Print Quality/TAG Cross-Reference

Poor quality prints are another indication of printer problems. Begin by running a set of test prints. Then, compare the test prints to the samples located in [Section 4, Print Quality Samples](#). The chart below summarizes the possible print quality problems you may encounter and recommends a TAG in Section 3 to follow to address the problem.

| Blank Prints | Go to TAG |
|----------------------------|------------------|
| Complete | 800 |
| Partial | 800 |
| With dark horizontal bands | 800 |

| Light Prints | Go to TAG |
|------------------------------------|------------------|
| With carrier particles | 801 |
| With background | 811 |
| With voids/white spots | 802 |
| With light vertical streaks | 803 |
| With blank or white vertical lines | 803 |
| With light horizontal bands | 804 |

| Dark Prints | Go to TAG |
|---|------------------|
| Dark black prints | 805 |
| With dark spots or scratches | 806 |
| With dark blotches | 810 |
| With dark vertical streaks (without fusing) | 812 |
| With dark vertical streaks (with fusing) | 808 |

| Skewed Prints | Go to TAG |
|----------------------|------------------|
| Simplex | 807 |
| Duplex | 901 |

| Misregistration | Go to TAG |
|------------------------|------------------|
| Simplex | 807 |
| Duplex | 901 |

| Smeared, Blurred, Uneven Prints | Go to TAG |
|--|------------------|
| Smeared vertical streaks | 809 |
| Blurred prints | 809 |
| Uneven density | 810 |
| Prints with background | 811 |
| Prints with background and residual images | 811 |
| Prints with residual images | 813 |
| Prints with offset images | 814 |

| Additional Print Quality Problems | Go to TAG |
|--|------------------|
| Wrinkled or torn prints | 706 |
| Prints improperly fused | 812 |
| Prints exhibiting printhead problems | 815 |

Mechanical Malfunction/TAG Cross-Reference

Mechanical Malfunction/TAG Cross-Reference

The chart below outlines possible mechanical malfunctions and recommends an appropriate TAG to follow to resolve the problem.

| Operator Panel Problems | Go to TAG |
|---|------------------|
| Blank with AC power fan and cooling fan on | 500 |
| Blank with AC power fan on | 500 |
| Blank with no fans on | 600 |
| All lights on | 610 |
| Incomplete display immediately after POR | 610 |
| "Close cover" displayed | 600 |
| Remove prints light remains on or lights | 700 |
| "Add toner" displayed | 035 |
| Machine check light is on with no numerical Display | 201 |
| One or more lights are off at POR | 610 |
| Tone not working | 610 |
| Incorrect paper size | 702 |
| Other operator panel malfunctions | 610 |

| Output Tray Problems | Go to TAG |
|------------------------------|------------------|
| Sensor not sensing condition | 701 |
| Jogging incorrectly | 083 |
| Will not stop jogging | 083 |
| Job offset incorrect | 083 |

| Cassette Problems | Go to TAG |
|--------------------------|------------------|
| Upper cassette | 703 |
| Lower cassette | 704 |

Mechanical Malfunction/TAG Cross-Reference

| Paper Handling Problems | Go to TAG |
|---|------------------|
| Multiple paper feed | 705 |
| Multiple sheet feeds and jams | 705 |
| Wrinkled or torn paper | 706 |
| Simplex: misregistration and paper skew | 807 |
| Duplex: misregistration and paper skew | 901 |
| Paper will not feed from upper cassette | 012 |
| Paper jam in duplex area | 902 |
| Upper paper guide not closing | 707 |

| Counter Problems | Go to TAG |
|---------------------------------------|------------------|
| Supplies seem to have short life span | 750 |
| Incorrect counting | 750 |

| Communication Problems | Go to TAG |
|----------------------------------|------------------|
| Printer will produce test prints | 753 |
| Incorrect data being printed | 753 |

| Additional Mechanical Malfunctions | Go to TAG |
|---|------------------|
| Test prints won't run after POR | 130 |
| Cooling fan not running | 752 |
| Vacuum transport fan not running | 752 |
| Circuit breaker trip | 600 |
| Main drive motor not turning off | 751 |

Mechanical Malfunction/TAG Cross-Reference

***Troubleshooting
Analysis Guides
(TAGs)***

Contents

Troubleshooting Analysis Guides

| | |
|---|------|
| TAG 001: Troubleshooting a Problem | 3-5 |
| TAG 002: Check Problem Resolution | 3-7 |
| TAG 010: Upper Cassette Malfunction | 3-10 |
| TAG 011: Lower Cassette Malfunction | 3-12 |
| TAG 012: Upper Cassette Not Latched | 3-14 |
| TAG 013: Lower Cassette Not Latched | 3-17 |
| TAG 020: Paper Jam/Misfeed in Upper Cassette Area | 3-19 |
| TAG 021: Paper Jam/Misfeed in Lower Cassette Area | 3-22 |
| TAG 022: Paper Jam in the Transfer or Fuser Area | 3-26 |
| TAG 023: Paper Jam in the Output Area | 3-30 |
| TAG 025: Paper in Input Area Before Printing | 3-32 |
| TAG 026: Paper in Output Area Before Printing | 3-34 |
| TAG 030: Developer Bias Short/Failure | 3-36 |
| TAG 031: Toner Patch Reference Level Incorrect | 3-39 |
| TAG 032: Toner Patch Too Light | 3-41 |
| TAG 035: Out of Toner or ADD TONER Indication | 3-43 |
| TAG 036: Developer Not Installed | 3-45 |
| TAG 040: Photoconductor Seam Sensor Malfunction | 3-46 |
| TAG 044: Charge Corona/Transfer Corona Circuit Open | 3-49 |
| TAG 045: Charge Corona Circuit Shorted | 3-52 |
| TAG 047: PC Life Data Error | 3-54 |
| TAG 048: Developer Life Error | 3-55 |
| TAG 050: Transfer Corona Circuit Shorted | 3-56 |
| TAG 055: Erase Lamp Malfunction | 3-58 |
| TAG 070: Fuser Malfunction | 3-60 |
| TAG 071: Open Fuser/Thermistor | 3-65 |
| TAG 072: Fuser Temperature Too High | 3-66 |
| TAG 097: +12 Vdc Power Shorted or Sensing Problem | 3-68 |
| TAG 098: -12 Vdc Power Shorted | 3-78 |
| TAG 099: +24 Vdc Power Shorted | 3-80 |
| TAG 100: VPCL Board Interface Malfunction | 3-89 |

| | |
|---|-------|
| TAG 130: Disk Drive Malfunction | 3-90 |
| TAG 200: RIGS Internal Communication Malfunction | 3-95 |
| TAG 201: RIGS-VPCL Interface Malfunction | 3-97 |
| TAG 405: RIGS Bit-Map RAM Malfunction | 3-99 |
| TAG 500: +5 Vdc Power Malfunction | 3-100 |
| TAG 600: Vac Power Malfunction | 3-105 |
| TAG 610: Operator Panel Malfunction | 3-112 |
| TAG 700: Output Tray Circuit Malfunction | 3-115 |
| TAG 702: Paper Size Detection Malfunction | 3-117 |
| TAG 703: Upper Cassette Malfunction | 3-120 |
| TAG 704: Lower Cassette Malfunction. | 3-121 |
| TAG 705: Multiple Paper Feeding | 3-122 |
| TAG 706: Paper Damaged or Wrinkled | 3-123 |
| TAG 707: Upper Paper Guide Assembly Not Closing | 3-124 |
| TAG 750: Counter Malfunction. | 3-125 |
| TAG 751: Main Drive Motor Runs Continuously. | 3-127 |
| TAG 753: Async I/O Communications Malfunction. | 3-128 |
| TAG 754: Smart I/O Card Malfunction. | 3-131 |
| TAG 800: Prints Blank or With Dark Horizontal Bands. | 3-133 |
| TAG 801: Prints Light or Light With Carrier Particles | 3-137 |
| TAG 802: Prints With Voids or White Spots | 3-142 |
| TAG 803: Prints With Light or White Vertical Streaks | 3-144 |
| TAG 804: Prints With Light Horizontal Bands. | 3-145 |
| TAG 805: Black Prints. | 3-146 |
| TAG 806: Prints with Dark Spots or Scratches | 3-148 |
| TAG 807: Misregistered/Skewed Prints | 3-150 |
| TAG 808: Prints Overtoned/Dark Vertical Streaks | 3-153 |
| TAG 809: Blurred or Smeared Vertical Streaks on Prints. | 3-157 |
| TAG 810: Uneven Density or Dark Areas on Prints | 3-161 |
| TAG 811: Background/Residual Images/Dark Prints | 3-162 |
| TAG 812: Uneven or No Fusing on Prints | 3-166 |
| TAG 813: Residual Images on Prints | 3-168 |
| TAG 815: Prints Resulting From Printhead Malfunctions | 3-170 |
| TAG 900: Top Cover Interlock Malfunction, Duplex | 3-171 |
| TAG 901: Misregistration/Skewed Prints (Duplex) | 3-173 |
| TAG 902: Paper Jam in Duplex Area | 3-177 |

Troubleshooting Analysis Guides

The Troubleshooting Analysis Guides (TAGs) contained in this section outline each of the TAGs used to diagnose and resolve specific printer problems related to error messages, print quality, and mechanical malfunctions. An overview of how the TAGs are organized and how to use them is included in [“Print Quality/TAG Cross-Reference” on page 2-12](#). If you are using a TAG for the first time, please refer to this section for more specific instructions. Also note that [Section 2, TAG Cross-Reference Tables](#), provides comprehensive charts which cross reference specific error messages, print quality problems, and mechanical malfunctions to the TAGs contained in this section.

As you use these TAGs, you may need to refer to other sections of this manual for additional information. Please turn to these sections as required.

- ! The shorthand convention “MC” is used in place of the words “Machine Check” when error messages that include this text are shown.

TAG 001: Troubleshooting a Problem

If you are not sure how to troubleshoot a printer problem, start with this TAG. This and all TAGs assume you are familiar with standard procedures, such as power-on-reset, presented in [Section 1, Troubleshooting](#). In addition, TAGs may refer you to [Section 2, TAG Cross- Reference Tables](#) which contains:

- Error message cross-reference table
Arranged by error message; refers you to the TAG associated with the message.
- Print quality cross-reference table
Arranged by description of print-quality problem; refers you to the TAG associated with the problem.
- Mechanical malfunction cross-reference table
Arranged by description of the mechanical malfunction; refers you to the TAG associated with the malfunction.

1

To start:

- Disconnect all peripheral cables.
- Power-on-reset the printer.

Did the printer display an error message?

No: Run test prints, following the procedure outlined in [Section 1, Troubleshooting](#) then repeat this step. If the answer is still no, refer to the mechanical malfunctions cross-reference chart in [Section 2, TAG Cross- Reference Tables](#) to determine which TAG to follow. Then turn to that TAG.

Yes: Note the error message and continue.

2

Power-on-reset the printer.

Did the power-on-reset end with an error message?

No: Continue.

Yes: Refer to the error message cross-reference table in [Section 2, TAG Cross- Reference Tables](#) using either the message that displayed after steps 1 and 2, or if multiple error messages continue to appear, the first error message that displays. Turn to the TAG associated with the message.

3

Did the printer READY light come on with no error message?

No: Continue.

Yes: Go to TAG 753.

4

Run test prints from the upper cassette by completing the following:

- Power-on-reset the printer.
- Run test prints from the upper cassette.

Did an error message appear while running the prints?

No: Continue.

Yes: Look up the message in the error message cross-reference chart to determine which TAG to follow, then turn to that TAG.

TAG 001: Troubleshooting a Problem

5 Run test prints from the lower cassette by completing the following:

- Press **STOP** and allow the cycle to finish.
- Remove the upper cassette.
- Power-on-reset the printer.
- Run test prints from the lower cassette.

Did an error message appear while running test prints?

No: Continue.

Yes: Look up the message in the error message cross-reference chart to determine which TAG to follow, then turn to that TAG.

6 Check communications by completing the following:

- Turn the printer off.
- Reinstall all communication cables.
- Reinstall the upper cassette.
- Power-on-reset the printer.
- Re-run the customer's problem print job.

Does the job fail?

No: Continue.

Yes: Go to TAG 753.

7 Complete the following:

- Run test prints.
- Re-run the customer's problem print job.

Does an error message appear?

No: Continue.

Yes: Look up the message in the error message cross-reference chart, then turn to TAG indicated in the chart.

8 Run a job which is known to be good.

- Compare the output from the problem print job to the output from the good print job.

Can you identify the problem?

No: Return to the beginning of the TAG, following the procedures carefully to determine the kind of problem your customer has.

Yes: Identify the problem as either a print quality problem or a mechanical malfunction, find the problem in the appropriate cross-reference chart, identify a TAG addressing that problem, then turn to that TAG.

TAG 002: Check Problem Resolution

- ! Follow the procedure outlined in this TAG when you have completed an action to resolve a problem, and are sent to this TAG from another TAG.

-
- 1** Complete any actions directing you to this TAG.
- Make sure all connectors, covers, parts, and hardware have been reinstalled.
- In the course of resolving the printer problem, did you complete the every-call cleaning procedure?**
- No:** Continue.
- Yes:** Go to #3 in this TAG.
-
- 2** Clean the printer thoroughly, following the every-call cleaning procedure described below.
- 1** Remove these major printer supplies:
- Photoconductor; place it in its protective packaging
 - Cleaner
 - Developer
 - Fuser
- 2** Inspect and vacuum the printer:
- Inspect the areas in the printer around the developer, cleaner, photoconductor, and fuser for damage and wear.
 - Vacuum these areas to remove all excess toner, contamination, and/or foreign objects.
- 3** Clean internal areas:
- Clean the erase lamp with a cotton swab.
 - Clean the printhead bias plates with a soft cloth.
 - Clean the LED lens with a cotton swab, making sure no lint remains on the lens.
- 4** Inspect and clean the fuser:
- ! Caution! The fuser may be hot.
- Inspect the fuser for damage and contamination; repair or replace as necessary.
 - Clean the fuser connector, both on the fuser and in the printer, with a cotton swab.
 - Vacuum in and around the rollers to remove excess toner, contamination, and any foreign objects.
 - Reinstall the fuser.
- 5** Inspect and clean the developer:
- Inspect the developer for damage or contamination; repair or replace as necessary.
 - Clean any excess toner from the developer with a soft cloth.
 - Clean the toner patch sensor lens with a cotton swab, making sure no lint remains on the lens.
 - Vacuum the felt areas around the magnetic roller, being careful not to vacuum toner from the magnetic roller.
 - Reinstall the developer.
- Inspect and clean the cleaner/charge corona:
- ! Caution! Handle gently to avoid breaking the charger wire.
- Inspect the charger wire for damage or contamination; repair or replace as necessary.
 - Remove the charge corona from the cleaner.
 - Clean the grid with the cleaner brush.
 - Remove the grid to expose the charger wire.
 - Clean the charger wire with a cotton swab or charger cleaning tool.
 - Reinstall the grid.
 - Clean any excess toner from the cleaner with a soft cloth.

TAG 002: Check Problem Resolution

- Reinstall the charge corona in the cleaner.
 - Reinstall the cleaner.
- 6** Clean and inspect the photoconductor area:
- !** Caution! Do not touch the photoconductor belt, as this *permanently* damages it.
- Clean the photoconductor seam sensor inside the printer with a cotton swab or compressed air.
 - Remove the photoconductor from its protective packaging.
 - Inspect the photoconductor for damage or contamination; repair or replace as necessary.
 - Reinstall the photoconductor.
- 7** Clean the transfer corona:
- !** Caution! Handle gently to avoid breaking the charger wire.
- Remove the transfer corona.
 - Clean the transfer corona housing with a soft cloth.
 - Clean the transfer corona wire with a cotton swab.
 - Reinstall the transfer corona.

Have you completed the every-call cleaning procedure?

No: Complete the procedure, then continue.

Yes: Continue.

-
- 3** Run test prints to confirm print quality, in both simplex and duplex modes and from upper and lower paper cassettes. When you enter test print mode by pressing the keys listed below, the following items print: a directory of the boot device and multiple listings of fonts; a continuous flow of test prints.

To run test prints:

- 1** Disconnect the host interface.
- 2** Make sure “Ready” displays on the panel.
- 3** Press **ONLINE**.
- 4** Press **MENU**
- 5** Press ∇ to highlight “Test Print”
- 6** Press \triangleright to select “Test Print”
- 7** Choose “Simplex” or “Duplex” (Duplex is the default. Press ∇ to choose simplex.)
- 8** Press \triangleright to start. A directory of the boot device and multiple listings of fonts prints. A continuous flow of the test pattern then prints.
- 9** To *stop* printing the test pattern, press \triangleleft . The printer will print all test prints stored in the printer’s buffer, then stop.

If the test pattern prints successfully, the problem probably originates with the host system or a protocol converter connected to the host.

Are the test prints clean and printing correctly?

No: Go to [Section 4, Print Quality Samples](#) to identify a sample with the problem you see in the test print, then turn to the TAG indicated.

Yes: Continue.

-
- 4** Clear the error log:
- 1** Enter the diagnostic mode of the printer:
 - a Turn off the printer and wait 5 seconds.
 - b Hold down the **MENU** and **STATUS** keys simultaneously as you turn the printer back on. Wait for all three LEDs to come on. This takes approximately 30 seconds.
 - 2** Press \triangleright to display the first available test. Once a test name is displayed, you use the ∇ key to move through the available tests.
 - a Press ∇ until “Clear Error Log” shows on the display.
 - 3** Press \triangleright to activate the procedure.
 - 4** Press: \triangleright to advance to the drive where the error log is maintained. This is usually the boot drive.
 - 5** Press: \triangleright to clear the error log on the selected drive.
 - 6** Press: \triangleleft to exit the procedure.
 - 7** Confirm that the error log has been cleared. Exit diagnostic mode (POR) and print the error log. All errors in all sections should be reset to zero.

Do the error log entries appear as 0000?

- No:** Return to the beginning of this step.
Yes: Continue.

-
- 5** Fill in the Repair/Maintenance record taped inside the printer’s front cover.
- Make sure the problem description and steps taken to resolve the problem are clearly documented.
 - Reinstall all connectors, covers, parts, and hardware.
- You have successfully resolved the printer’s problem. Congratulations!**

TAG 010: Upper Cassette Malfunction

ERROR MESSAGE:FALSE "UPPER CASSETTE EMPTY" MESSAGE

Possible Causes: *Cassette empty*
Paper incorrectly loaded

Possible Defects (not listed in any particular order):

Upper paper empty actuator
Upper paper empty sensor
Upper cassette tray
Upper pressure lever
Upper cassette release cam
Upper cassette release latch
Upper cassette release lever
Spring
Connectors/wiring
VPCL board

- 1** Make sure paper is in the upper cassette.
- Make sure the paper is loaded correctly so that the side and rear guides are positioned securely against the paper in the cassettes.
 - Power-on-reset the printer.
 - Run test prints.

Is a false "UPPER CASSETTE EMPTY" message displayed?

No: The paper was loaded incorrectly. Turn to TAG 002.

Yes: Continue.

- 2** Check upper cassette:
- Remove the upper cassette.
 - Inspect the upper paper empty sensor actuator for binding, or for a damaged or broken part.

Is it in good working order?

No: Replace the actuator, then turn to TAG 002.

Yes: Continue.

- 3** Power-on-reset the printer
- Run test prints.
- Is a false "UPPER CASSETTE EMPTY" message displayed?**

No: The upper paper empty sensor was bad.

Yes: Reinstall the old upper paper empty sensor and continue.

4

Check pressure lever:

- Reinsert the upper cassette.
- Watch the pressure lever as the cassette is inserted.

Does the pressure lever elevate the paper to the correct feeding position?

No: Check the following for defects or incorrect mounting:

- Cassette tray
- Damper assembly
- Upper pressure lever
- Upper cassette release cam
- Upper cassette release latch
- Wire cable, pulley and spring
- Upper cassette release lever

Replace the defective part, then turn to TAG 002.

Yes: Replace the VPCL board, then turn to TAG 002.

TAG 011: Lower Cassette Malfunction

ERROR MESSAGE:FALSE "LOWER CASSETTE EMPTY" MESSAGE

Possible Causes: *Cassette empty*
Paper incorrectly loaded

Possible Defects (not listed in any particular order):

Lower paper empty actuator
Lower paper empty sensor
Lower cassette tray
Lower pressure lever
Lower cassette release cam
Lower cassette release latch
Lower cassette release lever
Spring
Connectors/wiring
VPCL board

- 1** Make sure paper is in the lower cassette.
- Make sure the paper is loaded correctly so that the side and rear guides are positioned securely against the paper in the cassettes.
 - Power-on-reset the printer.
 - Run test prints.

Is a false "LOWER CASSETTE EMPTY" message displayed?

No: The paper was loaded incorrectly. Turn to TAG 002

Yes: Continue.

- 2** Remove the lower cassette.
- Inspect the lower paper empty sensor actuator for binding, or for a damaged or broken part.

Is it in good working order?

No: Replace the actuator, then turn to TAG 002.

Yes: Continue.

- 3** Power-on-reset the printer

- Run test prints.

Is a false "LOWER CASSETTE EMPTY" message displayed?

No: The lower paper empty sensor was bad.

Yes: Reinstall the old lower paper empty sensor and continue.

4

Reinsert the lower cassette.

- Watch the pressure lever as the cassette is inserted.

Does the pressure lever elevate the paper to the correct feeding position?

No: Check the following for defects or incorrect mounting:

- Cassette tray
 - Lower pressure lever
 - Lower cassette release cam
 - Lower cassette release latch
 - Wire cable, pulley and spring
 - Lower cassette release lever
- Replace the defective part, then turn to TAG 002.

Yes: Replace the VPCL board, then turn to TAG 002.

TAG 012: Upper Cassette Not Latched

ERROR MESSAGE:FALSE "UPPER CASSETTE NOT LATCHED" MESSAGE

Possible Defects (not listed in any particular order):

Upper cassette release cam
Upper cassette release latch
Upper cassette in latch
Upper pressure lever
Spring
Wire cable and pulley
Upper cassette
Upper cassette in switch
Upper paper size sensor
Lower paper size sensor
Connectors or wiring
VPCL board

-
- 1** Turn off the printer and unplug the power cord.
- Verify that J/P40 and J/P52 are connected properly.
 - Remove the upper cassette.
 - Inspect it for damage.
 - Reinsert the cassette.

Is the upper cassette properly latched?

No: Continue.

Yes: Go to #3 in this TAG.

-
- 2** Check for damage:
- Upper cassette release cam
 - Upper cassette release latch
 - Upper cassette in latch
 - Upper pressure lever
 - Spring
 - Wire cable and pulley

Are any of these parts damaged?

No: Return to the beginning of this TAG.

Yes: Replace the damaged parts, then turn to TAG 002.

-
- 3** Remove the upper cassette.
- Make sure the upper cassette in switch actuator is functioning properly.

Is it in good working order?

No: Replace the actuator, then turn to TAG 002.

Yes: Continue.

4 Run diagnostic test “[Upper Cassette Test](#)” on page 5-4.
Is UPPER CASSETTE TEST “NO CASSETTE” displayed?
No: Replace the VPCL board, then turn to TAG 002.
Yes: Continue.

5 Install the upper cassette.
Is a message other than “NO CASSETTE” displayed?
No: Continue.
Yes: Replace the VPCL board, then turn to TAG 002.

6 Turn the printer off and unplug the power cord.

- Remove the upper cassette.
- Loosen the upper paper size sensor assembly for access to the circuit board.
- Disconnect J/P46.
- Activate the cassette in switch.
- Check P46-1 to P46-2 for continuity.

Is there continuity?
No: Replace the upper cassette in switch or wire harness W58, then turn to TAG 002.
Yes: Continue.

7 Reconnect J/P46.

- Disconnect J/P40 and J/P45.
- Check P40-49 to P45-2 for continuity.

Is there continuity?
No: Go to [#10](#) in this TAG.
Yes: Continue.

8 Check P40-48 to P45-3 for continuity.
Is there continuity?
No: Continue.
Yes: Replace the upper paper size sensor assembly. If this does not resolve the problem, replace the VPCL board. Turn to TAG 002.

TAG 012: Upper Cassette Not Latched

9

Reconnect J/P40 and J/P45.

- Remove the lower cassette.
- Loosen the lower paper size sensor assembly for access to the circuit board.
- Disconnect J/P43 and J/P47.
- Check J43-8 to J47-3 for continuity.

Is there continuity?

No: Replace lower paper size sensor assembly, then turn to TAG 002.

Yes: Repair or replace the connectors or wiring from
P45-3 to P47-3,
P43-8 to J52-3, or
P40-48 to P52-3.

If this does not resolve the problem, replace the upper paper size sensor assembly. Then turn to TAG 002

10

Reconnect J/P40 and J/P45.

- Remove the lower cassette.
- Loosen the lower paper size sensor assembly for access to the circuit board.
- Disconnect J/P43 and J/P47.
- Check J43-9 to J47-2 for continuity.

Is there continuity?

No: Replace the lower paper size sensor assembly.

Yes: Repair or replace the connectors or wiring from
P45-2 to P47-2,
P43-9 to J52-2 or
P40-49 to P52-2.

If this does not resolve the problem, replace the upper paper size sensor assembly. Then turn to TAG 002

TAG 013: Lower Cassette Not Latched**ERROR MESSAGE:FALSE "LOWER CASSETTE NOT LATCHED" MESSAGE****Possible Defects (not listed in any particular order):**

Lower cassette release cam
Lower cassette release latch
Lower cassette in latch
Lower pressure lever
Spring
Lower cassette
Lower cassette in switch
Lower paper size sensor
Connectors or wiring
VPCL board

-
- 1** Turn the printer off and unplug the power cord.
- Verify that J/P40 and J/P52 are connected properly.
 - Remove the lower cassette.
 - Inspect it for damage.
 - Reinsert the cassette.

Is the lower cassette properly latched?**No:** Continue.**Yes:** Go to #3 in this TAG.

-
- 2** Check the following for damage:
- Lower cassette release cam
 - Lower cassette release latch
 - Lower cassette in latch
 - Lower pressure lever
 - Spring

Are any of these parts damaged?**No:** Return to the beginning of this TAG.**Yes:** Replace the damaged parts, then turn to TAG 002.

-
- 3** Remove the lower cassette.
- Make sure the lower cassette in switch actuator is functioning properly.

Is it in good working order?**No:** Replace the actuator, then turn to TAG 002.**Yes:** Continue.

-
- 4** Run self diagnostic test "[Lower Cassette Test](#)" on page 5-5.
- Is **LOWER CASSETTE TEST "NO CASSETTE"** displayed?
- No:** Replace the VPCL board, then turn to TAG 002.
- Yes:** Continue.

TAG 013: Lower Cassette Not Latched

- 5** Install the lower cassette.
Is a message other than “NO CASSETTE” displayed?
No: Continue.
Yes: Replace the VPCL board, then turn to TAG 002.
-

- 6** Turn the printer off and unplug the power cord.
- Remove the lower cassette.
 - Loosen the lower paper size sensor assembly for access to the circuit board.
 - Disconnect J/P48.
 - Activate the cassette in switch.
 - Check P48-1 to P48-2 for continuity.
- Is there continuity?**
No: Replace the lower cassette in switch or wire harness W59, then turn to TAG 002.
Yes: Continue.
-

- 7** Reconnect J/P48.
- Disconnect J/P43 and J/P40.
 - Check P40-50 to P43-10 for continuity.
- Is there continuity?**
No: Repair or replace the connectors or wiring from P43-10 to J52-1 or P40-50 to P52-1. Then turn to TAG 002.
Yes: Continue.
-

- 8** Check P43-8 to P40-48 for continuity.
Is there continuity?
No: Repair or replace the connectors or wiring from P43-8 to J52-3 or P40-48 to P52-3. Then turn to TAG 002.
Yes: Replace the lower paper size sensor assembly. If this does not resolve the problem, replace the VPCL board. Then turn to TAG 002.
-

TAG 020: Paper Jam/Misfeed in Upper Cassette Area

ERROR MESSAGE:PAPER JAM 020 UPPER CASSETTE

Possible Causes: *Paper incorrectly loaded*
Wrong weight or type of paper loaded
Paper path obstructed

Possible Defects (not listed in any particular order):
Upper pick-up roller assembly
Upper feed roller assembly
Upper pick-up roller drive assembly
Upper paper guide assembly
Lower paper guide assembly
Upper paper cassette
Pick pressure adjustment
Main drive gear assembly
Paper feed drive belt
Paper feed drive idler assembly
Paper timing sensor
Wiring or connectors
VPCL board

-
- 1** Check both paper paths and remove any paper jams.
- Make sure paper is loaded properly in both cassettes.
 - Make sure the paper guides are positioned properly.
 - Make sure the upper pick-up roller, feed roller, and pinch roller assemblies are clean.
 - Verify that J/P40, J/P60, J/P66, and J/P68 are connected properly.
 - Confirm that the paper in the cassettes meets paper specifications.
 - Power-on-reset the printer.
 - Run test prints from the upper cassette.

Is error message PAPER JAM 020 UPPER CASSETTE still displayed?

No: Go to #12 in this TAG.

Yes: Continue.

-
- 2** Turn the printer off and inspect the following for damage or binding:
- Upper paper guide assembly
 - Lower paper guide assembly
 - Paper feed drive belt
 - Paper feed drive pulley
 - Paper feed drive idler assembly
 - Main drive gear assembly
 - Upper pick-up roller drive assembly

Are all the parts in good working order?

No: Replace any damaged parts, then turn to TAG 002.

Yes: Continue.

TAG 020: Paper Jam/Misfeed in Upper Cassette Area

3

Clear the paper path.

- Remove the upper cassette.
- Power-on-reset the printer.
- Run test prints from the lower cassette.

Is error message PAPER JAM 021 LOWER CASSETTE displayed?

No: Go to #9 in this TAG.

Yes: Continue.

4

Clear the paper path.

- Inspect the paper timing sensor actuator for damage or binding.

Is it in good working order?

No: Replace the paper timing guide assembly, then turn to TAG 002.

Yes: Continue.

5

Replace the paper timing guide assembly.

- Power-on-reset the printer.
- Run test prints from the upper cassette.

Is error message PAPER JAM 020 UPPER CASSETTE still displayed?

No: Turn to TAG 002.

Yes: Reinstall the old paper timing guide assembly and continue.

6

Check J/P91-1 for +24 Vdc.

Is the voltage +24 Vdc?

No: Continue.

Yes: Replace the VPCL board, then turn to TAG 002.

7

Check J/P8-13 for +24 Vdc.

Is the voltage +24 Vdc?

No: Replace the DC power supply, then turn to TAG 002.

Yes: Repair or replace the connectors or wiring from P91-1 to P8-13, then turn to TAG 002.

8

Turn the printer off and unplug the power cord.

- Disconnect J/P40 and J/P57.
- Check the following for continuity:
 - P40-16 to P57-2,
 - P40-25 to P57-1, and
 - P40-12 to P57-3.

Is there continuity on all?

No: Repair or replace the connectors or wiring from P40-25 to J/P58-1 to P57-1, P40-16 to J/P58-2 to P57-2, or P40-12 to J/P58-3 to P57-3. Then turn to TAG 002.

Yes: Replace the paper timing guide. If this does not resolve the problem, replace the VPCL board. Then turn to TAG 002.

- 9** Turn the printer off.
- Open the back cover and install an interlock by-pass tool.
 - Remove the paper feed cover to expose the upper paper pick roller assembly.
- !** Use extreme caution as gears and belts are exposed.
- Run diagnostic test “[Roller Clutch Tests](#)” on page 5-7 to test the upper pick-up roller clutch.
 - Check P66 for a voltage change from +24 Vdc to 0 Vdc.
- Does the voltage change from +24 Vdc to 0 Vdc?**
- No:** Continue.
- Yes:** Go to [#12](#) in this TAG.
-

- 10** Turn off the printer and unplug the power cord.
- Disconnect J/P40 and J/P68.
 - Check P40-9 to J68-2 and P40-11 to J68-1 for continuity.
- Is there continuity?**
- No:** Repair or replace the connectors or wiring from
P40-9 to J68-2 or
P40-11 to J68-1.
Then turn to TAG 002.
- Yes:** Replace the upper pick-up roller assembly, then turn to TAG 002.
-

- 11** Turn off the printer and unplug the power cord.
- Disconnect J/P40 and J/P66.
 - Check P40-6 to J66-2 and P40-11 to J66-1 for continuity.
- Is there continuity?**
- No:** Repair or replace connectors or wiring from
P40-6 to J66-2 or
P40-11 to J66-1.
Then turn to TAG 002.
- Yes:** Replace the upper feed roller assembly, then turn to TAG 002.
-

- 12** Inspect the upper pick-up roller assembly for damage or binding.
- Is it in good working order?**
- No:** Replace the upper pick-up roller assembly, then turn to TAG 002.
- Yes:** Continue.
-

- 13** Inspect the upper feed roller assembly for damage or binding.
- Is it in good working order?**
- No:** Replace the upper feed roller assembly, then turn to TAG 002.
- Yes:** The upper pick-up roller or the feed rollers may not be delivering paper to the paper timing sensor at the correct time. Return to the beginning of this TAG.
-

TAG 021: Paper Jam/Misfeed in Lower Cassette Area

ERROR MESSAGE:PAPER JAM 021 LOWER CASSETTE

Possible Causes: *Paper loaded incorrectly*
Wrong weight or type of paper loaded
Paper path obstruction

Possible Defects (not listed in any particular order):
Lower pick-up roller assembly
Lower feed roller assembly
Lower pick-up roller drive assembly
Upper paper guide assembly
Lower paper guide assembly
Lower paper cassette
Pick pressure adjustment
Main drive gear assembly
Idler assembly
Paper feed drive belt
Paper feed drive idler assembly
Paper timing sensor
Wiring or connectors
VPCL board

1

Check both paper paths and remove any jams.

- Make sure paper is loaded properly in both cassettes.
- Make sure the paper guides are positioned properly.
- Check that the pick-up roller, feed roller, and backup roller assemblies are clean.
- Verify that J/P40, J/P62, J/P67, and J/P69 are connected properly.
- Confirm that the paper in the cassettes meets paper specifications, outlined in the HP 5000 Cut Sheet Printers Paper Specifications Guide, C4672-90002.
- Remove the upper cassette.
- Power-on-reset the printer.
- Run test prints from the lower cassette.

Is error message PAPER JAM 021 LOWER CASSETTE displayed?

No: Go to [#12](#) in this TAG.

Yes: Continue.

2 Turn the printer off and inspect the following for damage or binding:

- Lower paper guide assembly
- Upper paper guide assembly
- Paper feed drive belt
- Paper feed drive pulley
- Paper feed drive idler assembly
- Main drive gear assembly
- Lower pick-up roller drive assembly

Are all the parts in good working order?

No: Replace the damaged parts, then turn to TAG 002.

Yes: Continue.

3 Clear the paper path.

- Reinsert the upper cassette.
- Power-on-reset the printer.
- Run test prints from the upper cassette.

Is error message PAPER JAM 020 UPPER CASSETTE displayed?

No: Go to #9 in this TAG.

Yes: Continue.

4 Clear the paper path.

- Inspect the paper timing sensor actuator for damage or binding.

Is it in good working order?

No: Replace the paper timing guide assembly, then turn to TAG 002.

Yes: Continue.

5 Replace the paper timing guide assembly.

- Power-on-reset the printer.
- Run test prints from the lower cassette.

Is error message PAPER JAM 021 LOWER CASSETTE still displayed?

No: Turn to TAG 002.

Yes: Reinstall the old paper timing guide assembly and continue.

6 Check J/P91-1 for +24 Vdc.

Is the voltage +24 Vdc?

No: Continue.

Yes: Replace the VPCL board, then turn to TAG 002.

7 Check J/P8-13 for +24 Vdc.

Is the voltage +24 Vdc?

No: Replace the DC power supply, then turn to TAG 002.

Yes: Repair or replace the connectors or wiring from P91-1 to P8-13, then turn to TAG 002.

8

Turn the printer off and unplug the power cord.

- Disconnect J/P40 and J/P57.
- Check the following for continuity:
P40-16 to P57-2,
P40-25 to P57-1, and
P40-12 to P57-3.

Is there ground?

No: Repair or replace the connectors or wiring from:
P40-25 to J/P58-1 to P57-1,
P40-16 to J/P58-2 to P57-2, or
P40-12 to J/P58-3 to P57-3.
Then turn to TAG 002.

Yes: Replace the paper timing guide. If this does not correct the problem, replace the VPCL board.
Then turn to TAG 002.

9

Turn off the printer.

- Open the back cover and install an interlock by-pass tool.
- Remove the paper feed cover to expose the lower paper pick-up assembly.
- ! Use extreme caution as gears and belts are exposed.
- Run diagnostic test “[Roller Clutch Tests](#)” on [page 5-7](#) to test the lower pick-up roller clutch.
- Check P67 for a voltage change from +24 Vdc to 0 Vdc.

Does the voltage change from +24 Vdc to 0 Vdc?

No: Continue.

Yes: Go to [#12](#) in this TAG.

10

Turn the printer off and unplug the power cord.

- Disconnect J/P40 and J/P69.
- Check P40-8 to J69-2 and P40-10 to J69-1 for continuity.

Is there continuity?

No: Repair or replace the connectors or wiring from:
P40-8 to J69-2 or
P40-10 to J69-1.
Then turn to TAG 002.

Yes: Replace the lower pick-up roller assembly, then turn to TAG 002.

11

Turn the printer off and unplug the power cord.

- Disconnect J/P40 and J/P67.
- Check P40-5 to J67-2 and P40-11 to J67-1 for continuity.

Is there continuity?

No: Repair or replace the connectors or wiring from:
P40-5 to J67-2 or
P40-11 to J67-1.
Then turn to TAG 002.

Yes: Replace the lower feed roller assembly, then turn to TAG 002.

12 Inspect the lower pick-up roller assembly for damage or binding.

Is it in good working order?

No: Replace the lower pick-up roller assembly, then turn to TAG 002.

Yes: Continue.

13 Inspect the lower feed roller assembly for damage or binding.

Is it in good working order?

No: Replace the lower feed roller assembly, then turn to TAG 002.

Yes: The lower pick-up roller or lower feed roller may not be delivering the paper to the paper timing sensor at the correct time. Return to the beginning of this TAG.

TAG 022: Paper Jam in the Transfer or Fuser Area

ERROR MESSAGE:PAPER JAM 022 TRANSFER/FUSER

Possible Causes: *Paper loaded incorrectly*
Wrong weight or type of paper loaded
Paper path obstruction

Possible Defects (not listed in any particular order):

Fuser
Paper supply
Paper timing roller assembly
Fuser drive assembly
Fuser drive belt
Vacuum transport
Exit roller assembly
Upper paper guide assembly
Lower paper guide assembly
Paper timing guide assembly
Pick pressure adjustment
VPCL board
Connectors or wiring

! When clearing this jam, be careful not to get toner on your clothing, as it may stain. If toner gets on your clothes, rinse your clothes with cold water immediately to avoid stains.

1 Check the paper path and remove any jammed paper.

! Caution! The fuser may be very hot. Use caution when you:

- Check the fuser for paper wrapped around the heat roller.

Is paper wrapped around the heat roller?

No: Continue.

Yes: If the paper is black or very dark with no printing, go to TAG 805. If the paper is very dark and does have printing, go to TAG 811.

2 Check both paper paths for damage or obstructions.

- Confirm that J/P13, J/P22, J/P40, J/P58, and J/P65 are connected properly.
- Check that the paper is properly loaded.
- Confirm that the paper in the cassettes meets paper specifications.
- Check that the fuser is installed properly.
- Power-on-reset the printer.
- Run test prints.

Is error message PAPER JAM 022 TRANSFER/FUSER still displayed?

No: Paper incorrectly loaded, incorrect paper type in use, or a loose connector was at fault. Turn to TAG 002.

Yes: Continue.

3 Has the fuser been replaced recently?

No: Continue.

Yes: Go to #5 in this TAG.

4 Replace the fuser.

- Run test prints.

Has the problem been resolved?

No: Reinstall the original fuser and continue.

Yes: The fuser was at fault. Turn to TAG 002.

5 Inspect the following for damage:

- Upper paper guide assembly
- Paper timing roller assembly
- Lower paper guide assembly
- Paper timing guide assembly

Are any of these parts damaged?

No: Continue.

Yes: Replace the damaged part, then turn to TAG 002.

6 Is more than one sheet of paper jamming?

No: Go to #8 in this TAG.

Yes: Continue.

7 Make sure the natural curl of the paper is turned up in the cassettes.

- Make sure the paper is under the corner separators.
- Make sure the rear and side paper guides are positioned properly.
- Make sure the paper being used does not have a high static charge.
- Run test prints.

Does the multiple feed problem still exist?

No: The paper appears to be at fault. Turn to TAG 002.

Yes: Adjust the paper tension lever or pick pressure, as outlined in [Section 9, General Printer Maintenance](#), then turn to TAG 002.

8 Check the paper path for jams.

- Open the printer's front cover and insert the interlock bypass tool.
- Power-on-reset the printer.
- Run test prints.
- Watch the end of the paper timing roller shaft.

Does the paper timing roller shaft turn?

No: Continue.

Yes: Go to #13 in this TAG.

TAG 022: Paper Jam in the Transfer or Fuser Area

9 Check J/P91-1 for +24 Vdc.

Is the voltage +24 Vdc?

No: Continue.

Yes: Replace the VPCL board, then turn to TAG 002.

10 Check J/P8-13 for +24 Vdc.

Is the voltage +24 Vdc?

No: Replace the DC power supply, then turn to TAG 002.

Yes: Repair or replace the connectors or wiring from P91-1 to P8-13, then turn to TAG 002.

11 Run diagnostic test “[Roller Clutch Tests](#)” on [page 5-7](#) to test the paper timing roller clutch.

- Check P65 for a voltage change from +24 Vdc to 0 Vdc.

Does the voltage change from +24 Vdc to 0 Vdc?

No: Continue.

Yes: Go to [#13](#) in this TAG.

12 Turn off the printer and unplug the power cord.

- Disconnect J/P40 and J/P65.
- Check P40-7 to J65-2 and P40-11 to J65-1 for continuity.

Is there continuity on both?

No: Repair or replace the connectors and wiring from:
P40-7 to J65-2 or
P40-11 to J65-1.
Then turn to TAG 002.

Yes: Replace the paper timing roller assembly, then turn to TAG 002.

13 **Does paper stop or jam either before or during entry into the fuser?**

No: Go to [#16](#) in this TAG.

Yes: Continue.

14 Remove the fuser.

- Check the fuser rollers for damage or toner contamination.

Are they damaged or contaminated with toner?

No: Continue.

Yes: Replace the fuser, then turn to TAG 002.

15 Inspect the following for damage or binding:

- fuser
- Fuser drive belt
- Fuser drive assembly

Are any of these parts damaged?

No: Go to [#21](#) in this TAG.

Yes: Replace the damaged parts, then turn to TAG 002.

-
- 16** Turn the printer off.
- Check for paper jams.
 - Inspect the exit roller, and exit pinch roller assemblies for damage, binding and contamination.
- Are these parts in good working order?**

No: Repair or replace the defective parts, then turn to TAG 002.

Yes: Continue.

-
- 17** Run test prints.
- Check the leading edge of the prints for improper registration.
- Is there improper registration?**

No: Continue.

Yes: Go to TAG 807 or TAG 901.

-
- 18** Inspect the vacuum transport for damage or binding.
- Are the parts in good working order?**

No: Repair or replace the vacuum transport, then turn to TAG 002.

Yes: Continue.

-
- 19** Open the top cover and install an interlock by-pass tool.
- Power-on-reset the printer.
 - While the main motor is running, cover all of the holes in the vacuum transport with a piece of paper.
- Does the vacuum transport fan hold the paper in place?**

No: Continue.

Yes: Return to the beginning of this TAG.

-
- 20** **! Use extreme caution:** Check for 100 Vac from J/P22-1 to J/P22-2.
- Is the voltage 100 Vac?**

No: Continue.

Yes: Replace the vacuum transport assembly.

-
- 21** Power-on-reset the printer.
- ! Use extreme caution:**
- While the main motor is running, monitor J/P13-6 and J/P13-3 for 100 Vac.
- Is the voltage 100 Vac?**

No: Replace the power control board, then turn to TAG 002.

Yes: Repair or replace the connectors or wiring from J22-1 to P13-6 or J22-2 to P13-3. Then turn to TAG 002.

TAG 023: Paper Jam in the Output Area

ERROR MESSAGE:PAPER JAM 023 AT/NEAR EXIT

Possible Causes: *Paper path obstruction*
Output tray obstruction

Possible Defects (not listed in any particular order):

Exit paper sensor
Fuser drive
Exit roller assembly
Exit pinch roller assembly
VPCL board
Connectors or wiring

! If the printer has a high capacity output unit (HCO), unplug and remove it before you begin. Test the printer without the HCO; if the problem remains, proceed with this TAG. If the problem occurs only with the HCO, the HCO is causing the problem. Repair or replace the HCO.

- 1** Turn the printer off and unplug the power cord.
- Verify that J/P50 and J/P40 are connected properly.
 - Check the paper path and remove any paper jams.
 - Check the output tray and remove any paper jams.
 - Power-on-reset the printer.
 - Run test prints.

Is error message PAPER JAM 023 AT/NEAR EXIT displayed?

No: Loose connectors or obstructions were at fault. Turn to TAG 002.

Yes: Continue.

- 2** **Is paper stopped or jammed at the output tray?**

No: Continue.

Yes: Go to #5 in this TAG.

- 3** Inspect the exit paper sensor actuator for damage or binding.

Is it in good working order?

No: Repair or replace the exit paper sensor actuator, then turn to TAG 002.

Yes: Continue.

4 Turn the printer off and unplug the power cord.

- Disconnect J/P40 and J/P49.
- Check the following for continuity:
P40-24 to P49-2,
P40-26 to P49-1, and
P40-13 to P49-3.

Is there continuity?

No: Repair or replace the connectors or wiring from:
P40-26 to J/P50-1 to P49-1,
P40-24 to J/P50-2 to P49-2, or
P40-13 to J/P50-3 to P49-3.

Yes: Replace the exit paper sensor.

5 Turn the printer off and unplug the power cord.

- Open the back cover and install an interlock bypass tool.
- Remove the fuser drive cover.
- Inspect the following for damage, binding, or contamination:
 - Exit roller assembly
 - Exit roller drive gear
 - Exit pinch roller assembly

Are all the parts in good working order?

No: Replace the defective parts, then turn to TAG 002.

Yes: Continue.

6 Remove the fuser.

- Inspect the following for damage or binding:
 - Fuser drive assembly
 - Fuser drive belt
 - Main drive gear assembly

Are all the parts in good working order?

No: Replace the defective parts, then turn to TAG 002.

Yes: Reinstall the fuser and continue.

7 Run diagnostic test "[Photoconductor Seam Sensor Test](#)" on page 5-8.

- Watch the fuser drive and the exit roller assembly.

Are they in good working order?

No: Replace the defective parts, then turn to TAG 002.

Yes: Replace the fuser, then turn to TAG 002.

TAG 025: Paper in Input Area Before Printing

ERROR MESSAGE:PAPER JAM 025 AT/NEAR INPUT

Possible Defects (not listed in any particular order):

Paper timing sensor
VPCL board
Connectors or wiring

-
- 1** Turn the printer off and unplug the power cord.
- Check the paper path and remove any paper jams.
 - Confirm that J/P58 and J/P40 are connected properly.
 - Inspect the paper timing sensor actuator for damage or binding.

Is it in good working order?

No: Replace the paper timing guide assembly and continue.

Yes: Continue.

-
- 2** Power-on-reset the printer.
Is error message PAPER JAM 025 AT/NEAR INPUT displayed?

No: Jammed paper, loose connectors, or the sensor actuator were at fault. Turn to TAG 002.

Yes: Continue.

-
- 3** Replace the VPCL board.
- Power-on-reset the printer.
- Is error message PAPER JAM 025 AT/NEAR INPUT displayed?**

No: Turn to TAG 002.

Yes: Reinstall the old VPCL board and continue.

-
- 4** Loosen the paper timing guide.
- Confirm that J/P57 is connected properly.
- Is J/P57 connected properly?**

No: Continue.

Yes: Go to #6 in this TAG.

-
- 5** Reconnect J/P57.
- Reinstall the paper timing guide.
 - Power-on-reset the printer.
- Is error message PAPER JAM 025 AT/NEAR INPUT still displayed?**

No: J/P57 was at fault. Turn to TAG 002.

Yes: Continue.

6 Turn the printer off and unplug the power cord.

- Loosen the paper timing guide.
- Disconnect J/P57 and J/P40.
- Check the following for continuity:
 - P40-16 to P57-2,
 - P40-25 to P57-1, and
 - P40-12 to P57-3.

Is there continuity?

No: Repair or replace the connectors or wiring from:

- P40-25 to J/P58-1 to P57-1,
 - P40-16 to J/P58-2 to P57-2, or
 - P40-12 to J/P58-3 to P57-3.
- Then turn to TAG 002.

Yes: Replace the paper timing guide. If that doesn't resolve the problem, replace the VPCL board.
Then turn to TAG 002.

TAG 026: Paper in Output Area Before Printing

ERROR MESSAGE:PAPER JAM 026 AT/NEAR OUTPUT

Possible Defects (not listed in any particular order):

Exit paper sensor
VPCL board
Connectors or wiring

- !** If the printer has a high capacity output unit (HCO), unplug and remove it before beginning this TAG. Test the printer without the HCO; if the problem remains, proceed with this TAG. If the problem occurs only with the HCO, the HCO is causing the problem. Repair or replace the HCO.

-
- 1** Turn the printer off and unplug the power cord.
- Check the paper path and remove any paper jams.
 - Confirm that J/P50 and J/P40 are connected properly.
 - Inspect the exit paper sensor actuator for damage or binding.

Is it in good working order?

No: Replace the exit paper sensor actuator and continue.

Yes: Continue.

-
- 2** Power-on-reset the printer.

Is error message PAPER JAM 026 AT/NEAR OUTPUT displayed?

No: Jammed paper, loose connectors, or sensor actuator were at fault; go to TAG 002.

Yes: Continue.

-
- 3** Check J/P40-26 for +12 Vdc.

Is the voltage +12 Vdc?

No: Replace the VPCL board, then turn to TAG 002.

Yes: Continue.

4 Turn off the printer and unplug the power cord.

- Remove the exit cover.
- Disconnect J/P49 and J/P40.
- Check the following for continuity:
P40-26 to P49-1,
P40-24 to P49-2, and
P40-13 to P49-3

Is there continuity?

No: Repair or replace the connectors or wiring from:

- P40-26 to J/P50-1 to P49-1,
 - P40-24 to J/P50-2 to P49-2, or
 - P40-13 to J/P50-3 to P49-3.
- Then turn to TAG 002.

Yes: Replace the exit paper sensor. If that doesn't resolve the problem, replace the VPCL board.
Then turn to TAG 002.

TAG 030: Developer Bias Short/Failure

ERROR MESSAGE:MC DEVELOPER BIAS SHORT #030

Possible Defects (not listed in any particular order):

Cleaner
High voltage power supply
DC power supply
Connectors or wiring
VPCL board
Printhead assembly
Power control #2 board
Developer

-
- 1** Turn the printer off and unplug the power cord.
- Verify that J/P23, J/P24, J/P40, J/P41, J/P96, and J/P85 are connected properly.
 - Power-on-reset the printer.

Is error message MC DEVELOPER BIAS SHORT #030 still displayed?

No: A loose connector was at fault. Turn to TAG 002.

Yes: Continue.

- 2** Refer to [Section 9, General Printer Maintenance](#) and check the voltages.

Are the voltages correct?

No: Replace the high voltage power supply, then turn to TAG 002.

Yes: Continue.

- 3** **Has the developer been replaced recently?**

No: Go to [#5](#) in this TAG.

Yes: Continue.

- 4** Replace the cleaner.

- Run test prints.

Is error message MC DEVELOPER BIAS SHORT #030 still displayed?

No: The cleaner was defective; turn to TAG 002.

Yes: Reinstall the original cleaner and go to [#6](#) in this TAG.

- 5** Replace the developer.

- Install a new toner cartridge.
- Run test prints.

Is error message MC DEVELOPER BIAS SHORT #030 still displayed?

No: The developer was defective; turn to TAG 002.

Yes: Reinstall the original developer and continue.

-
- 6** Open the back cover and install an interlock by-pass tool.
- Check J/P23-5 for +24 Vdc.
- Is the voltage +24 Vdc?**
- No:** Repair or replace the connectors or wiring from P41-35 to P23-5, then turn to TAG 002.
- Yes:** Continue.

-
- 7** Turn the printer off and unplug the power cord.
- Disconnect J/P41 and J/P24.
 - Check the following for continuity
P41-31 to P24-1,
P41-30 to P24-2, and
P41-40 to P24-3.
- Is there continuity?**
- No:** Repair or replace the connectors or wiring from:
P41-31 to P24-1,
P41-30 to P24-2, or
P41-40 to P24-3.
Then turn to TAG 002.
- Yes:** Continue.

-
- 8** Disconnect P85 from the high voltage power supply.
- Check P85-3 to J25-7 for continuity.
- Is there continuity?**
- No:** Repair or replace the connectors or wiring from P85-3 to J25-7, then turn to TAG 002.
- Yes:** Continue.

-
- 9** Disconnect J/P96.
- Check P96-1 to J25-7 for continuity.
- Is there continuity?**
- No:** Repair or replace the developer power supply lead from
J/P96-1 to P85-3, then turn to TAG 002.
- Yes:** Replace the high voltage power supply, then turn to TAG 002.

-
- 10** Power-on-reset the printer.
- Is error message MC DEVELOPER BIAS SHORT #030 still displayed?**
- No:** The VPCL board was defective. Go to TAG 002.
- Yes:** Replace the VPCL board and continue.

-
- 11** Check J/P12-1 for +24 Vdc.
- Is the voltage +24 Vdc?**
- No:** Continue.
- Yes:** Repair or replace the connectors or wiring from P40-27 to P12-1, then turn to TAG 002.

TAG 030: Developer Bias Short/Failure

12 Check J/P11-1 for +24 Vdc.

Is the voltage +24 Vdc?

No: Continue.

Yes: Replace the power control #2 board, then turn to TAG 002.

13 Check J/P8-11 for +24 Vdc.

Is the voltage +24 Vdc?

No: Replace the DC power supply, then turn to TAG 002.

Yes: Repair or replace the connectors or wiring from P8-11 to P11-1, then turn to TAG 002.

TAG 031: Toner Patch Reference Level Incorrect

**ERROR MESSAGE:MC TPS TOO LOW #031
MC TPS TOO HIGH #037**

Possible Causes: *Contamination of the toner patch sensor or printhead lens*

Possible Defects (not listed in any particular order):

*Photoconductor
Connectors or wiring
VPCL board
Developer*

- 1** Turn the printer off and unplug the power cord.
- Refer to [Section 9, General Printer Maintenance](#), and perform the every-call cleaning procedure.
 - Clean the toner patch sensor on the developer.
 - Clean the printhead lens.
 - Run at least 200 test prints to detone the printer's engine.

Has the problem been resolved?

No: Contamination was at fault. Turn to TAG 002.

Yes: Continue.

- 2** Refer to [Section 9, General Printer Maintenance](#), and check the voltages.

Are the voltages correct?

No: Replace the high voltage power supply, then turn to TAG 002.

Yes: Continue.

- 3** **Have the photoconductor and developers been replaced recently?**

No: Continue.

Yes: Go to [#6](#) in this TAG.

- 4** Replace the photoconductor.

- Run 200+ test prints to reduce toner concentration in the developer.

Has the problem been resolved?

No: Reinstall the original photoconductor and continue.

Yes: The photoconductor was at fault; turn to TAG 002.

- 5** Replace the developer.

- Run test prints.

Has the problem been resolved?

No: Reinstall the original developer and continue.

Yes: Turn to TAG 002. If the problem reappears, the toner/carrier mix may be old or contaminated.

TAG 031: Toner Patch Reference Level Incorrect

6 Turn the printer off and unplug the power cord.

- Remove the developer.
- Disconnect J/P41.
- Check P41-47 to J25-3 for continuity.

Is there continuity?

No: Repair or replace the connectors or wiring from P41-47 to J25-3.

Yes: Replace the VPCL board, then turn to TAG 002.

TAG 032: Toner Patch Too Light

**ERROR MESSAGE:MC TPS TOO LIGHT #032
MC TPS SIGNAL OVERLOAD #033**

Possible Defects (not listed in any particular order):

Photoconductor
RIGS board
VPCL board

-
- 1** Refer to [Section 9, General Printer Maintenance](#), and check the voltages.
Are the voltages correct?
No: Replace the high voltage power supply, then turn to TAG 002.
Yes: Continue.
-
- 2** **Has the photoconductor been replaced recently?**
No: Continue.
Yes: Go to [#4](#) in this TAG.
-
- 3** Replace the photoconductor.
 - Run 200+ test prints to reduce toner concentration in the developer.**Has the problem been resolved?**
No: Reinstall the original photoconductor and continue.
Yes: The photoconductor was at fault. Turn to TAG 002.
-
- 4** Turn the printer off and unplug the power cord.
 - Refer to [Section 9, General Printer Maintenance](#), and perform the every-call cleaning procedure.
 - Clean the toner patch sensor on the developer.
 - Clean the printhead lens.
 - Run at least 55 test prints.**Has the problem been resolved?**
No: Contamination was at fault. Turn to TAG 002.
Yes: Continue.
-
- 5** Run test prints.
Do the test prints appear overtoned, dark, or have background?
No: Go to [#8](#) in this TAG.
Yes: Continue.
-
- 6** Develop a toner patch, as described in [Section 1, Troubleshooting](#).
Is the toner patch developed and properly positioned?
No: Replace the RIGS board, then turn to TAG 002.
Yes: Continue.

TAG 032: Toner Patch Too Light

7 Check the toner patch sensor board in the developer for loose wiring connectors.

Are all connectors and wiring connected properly?

No: Reconnect the wiring and connectors or replace the developer, then turn to TAG 002.

Yes: Go to TAG 808, TAG 811, or both, to identify the problem further.

8 **Do the prints appear light or blank?**

No: Replace the VPCL board, then turn to TAG 002.

Yes: Replace the photoconductor, then turn to TAG 002.

TAG 035: Out of Toner or ADD TONER Indication

ERROR MESSAGE:MC TONER EMPTY ERROR #035

Possible Causes: *Photoconductor*
Toner cartridge seal not removed
Toner cartridge empty
High print coverage

Possible Defects (not listed in any particular order):
VPCL board
Developer connectors or wiring

! An **MC TPS SIGNAL OVERLOAD #035** error may occur if the print coverage exceeds 25%. Do not run high print coverage jobs for extended periods of time.

-
- 1** Power-on-reset the printer.
- Run test prints.
- Is error message MC TONER EMPTY ERROR #035 displayed?**
- No:** Continue.
- Yes:** Refer to [Section 9, General Printer Maintenance](#), and perform the every-call cleaning procedure. Clean the toner patch sensor and the printhead lens, then continue.
-
- 2** Refer to [Section 9, General Printer Maintenance](#), and check the voltages.
- Are the voltages correct?**
- No:** Replace the high voltage power supply, then turn to TAG 002.
- Yes:** Continue.
-
- 3** **Has the photoconductor been replaced recently?**
- No:** Continue.
- Yes:** Go to [#5](#) in this TAG.
-
- 4** Replace the photoconductor.
- Run 200+ test prints to reduce toner concentration in the developer.
- Has the problem been resolved?**
- No:** Reinstall the original photoconductor and continue.
- Yes:** The photoconductor was at fault. Turn to TAG 002.
-
- 5** **Has the seal has been removed from the toner cartridge?**
- No:** Continue.
- Yes:** Go to [#7](#) in this TAG.

TAG 035: Out of Toner or ADD TONER Indication

6 Remove the toner cartridge seal.

- Power-on-reset the printer.
- Run test prints.

Has the problem been resolved?

No: Continue.

Yes: The toner cartridge seal was at fault. Turn to TAG 002.

7 Turn the printer off and unplug the power cord.

- Disconnect J/P41.
- Remove the developer.
- Check P41-48 to J25-6 for continuity.

Is there continuity?

No: Repair or replace the connectors or wiring from P41-48 to J25-6, then turn to TAG 002.

Yes: Replace the VPCL board. If this resolves the problem, then turn to TAG 002. If the problem is still not resolved, go to TAG 610.

TAG 036: Developer Not Installed

**ERROR MESSAGE:MC NO DEVELOPER #036
MC DEVELOPER CONN. OPEN #037**

Possible Defects (not listed in any particular order):
Developer not installed properly
Connectors or wiring
VPCL board

-
- 1** Turn the printer off and unplug the power cord.
- Make sure the developer is installed properly.
 - Confirm that J/P41 is connected properly.
 - Confirm that the proper developer is installed.
 - Power-on-reset the printer.
- Is error message MC NO DEVELOPER #036 displayed?**
- No:** A loose connector or improper developer was at fault. Turn to TAG 002.
- Yes:** Continue.
-
- 2** Refer to [Section 9, General Printer Maintenance](#), and check the voltages.
- Are the voltages correct?**
- No:** Replace the high voltage power supply, then turn to TAG 002.
- Yes:** Continue.
-
- 3** Turn the printer off and unplug the power cord.
- Disconnect J/P41.
 - Check P41-45 to P41-46 for continuity.
- Is there continuity?**
- No:** Continue.
- Yes:** Replace the VPCL board, then turn to TAG 002.
-
- 4** Remove the developer.
- Check P41-45 to J25-12 and P41-46 to J25-8 for continuity.
- Is there continuity on both?**
- No:** Repair or replace the connectors or wiring from:
P41-45 to J25-12 or
P41-46 to J25-8,
then turn to TAG 002.
- Yes:** Replace the developer, then turn to TAG 002.
-

TAG 040: Photoconductor Seam Sensor Malfunction

ERROR MESSAGE:MC NO SIGNAL FROM PSS #040
MC PSS SENSOR SHORTED #041
MC PSS SENSOR OPEN #042

Possible Defects (not listed in any particular order):

Photoconductor
Main motor gear
Main motor gear keys
Main drive gear assembly
Main drive motor assembly
Connectors or wiring
VPCL board
Software
Seam sensor

-
- 1** Turn the printer off and unplug the power cord.
- Verify that J/P4, J/P9, J/P12, J/P14, J/P20, J/P40, J/P41, J/P63 (photoconductor seam sensor), J/P64, J/P251, and J/P252 are connected properly.
 - Remove the photoconductor.
 - Clean the photoconductor contacts, the guide rail contacts, and the photoconductor cavity.
 - Clean the seam sensor lens and cavity, and remove any obstructions.
 - Reinstall the photoconductor.
 - Power-on-reset the printer.

Is error message MC NO SIGNAL FROM PSS #040, MC PSS SENSOR SHORTED #041 or MC PSS SENSOR OPEN #042 still displayed?

No: Loose connectors or dirty contacts were at fault. Turn to TAG 002.

Yes: Continue.

-
- 2** **Has the photoconductor been replaced recently?**

No: Continue.

Yes: Go to #4 in this TAG.

-
- 3** Replace the photoconductor.

- Run test prints.

Has the problem been resolved?

No: Reinstall the original photoconductor and continue.

Yes: The photoconductor was at fault. Turn to TAG 002.

-
- 4** Open the top cover and insert an interlock by-pass tool.

- Run the diagnostic test “[Photoconductor Seam Sensor Test](#)” on page 5-8.

Does the photoconductor belt rotate?

No: Continue.

Yes: Go to #11 in this TAG.

5 Is error message **MC PSS Sensor Shorted #041** or **MC PSS Sensor Open #042** displayed while running **“Photoconductor Seam Sensor Test”** on page 5-8?

No: Continue.

Yes: Go to [#12](#) in this TAG.

6 Turn the printer off.

- Remove the photoconductor.
- Inspect it for damaged drive mechanism or belt slippage.

Is it in good working order?

No: Replace the photoconductor, then turn to TAG 002.

Yes: Continue.

7 Reinstall the photoconductor.

- Remove the interlock by-pass tool and close the top cover.
- Open the back cover and install an interlock by-pass tool.
- Remove the main drive motor assembly cover.
- Turn the printer on.
- Run diagnostic test **“Photoconductor Seam Sensor Test”** on page 5-8.
- Watch the main motor.

Does the main motor gear turn while running the Photoconductor Seam Sensor Test?

No: Continue.

Yes: Replace the main motor gear, main motor gear key, or both, or replace the main drive gear assembly, as needed. Then turn to TAG 002.

8 Run diagnostic test **“Photoconductor Seam Sensor Test”** on page 5-8.

! Use extreme caution:

- Check J/P20-2 to J/P20-3 for 100 Vac while the test is running.

Is the voltage 100 Vac?

No: Continue.

Yes: Replace the main drive motor assembly, then turn to TAG 002.

9 Run diagnostic test **“Photoconductor Seam Sensor Test”** on page 5-8.

! Use extreme caution:

- Check J/P14-2 to J/P14-3 for 100 Vac while the test is running.

Is the voltage 100 Vac?

No: Continue.

Yes: Repair or replace the connectors or wiring from:

P14-2 to P20-3 or

P14-3 to P20-2;

then turn to TAG 002.

TAG 040: Photoconductor Seam Sensor Malfunction

10 Turn the printer off and unplug the power cord.

- Disconnect J/P40 and J/P12.
- Check P40-33 to P12-7 for continuity.

Is there continuity?

No: Repair or replace the connectors or wiring from P40-33 to P12-7.

Yes: Replace the power control board; if this does not correct the problem, replace the VPCL board. Then turn to TAG 002.

11 Remove the photoconductor.

- Inspect the photoconductor belt for damage.
- Check the timing hole for contamination or blockage.

Are the photoconductor belt and the timing hole both in good working order?

No: Replace the photoconductor, then turn to TAG 002.

Yes: Continue.

12 Turn the printer off.

- Disconnect J/P40.
- Turn the printer on.
- Check J40-20 for +12 Vdc.

Is the voltage +12 Vdc?

No: Replace the VPCL board, then turn to TAG 002.

Yes: Continue.

13 Check J/P64 pin 2 for between +2 to +6 Vdc.

! On J/P64, pin 1 is the top pin.

Is the voltage between +2 to +6 Vdc?

No: Replace the VPCL board, then turn to TAG 002.

Yes: Continue.

14 Turn the printer off and unplug the power cord.

- Remove the photoconductor.
- Disconnect J/P63, observing carefully the plug's orientation before you remove it.
- Check the following for continuity:
 - P40-19 to J/P64-1 to J/P252, which is the center connector contact on the photoconductor guide rail;
 - P40-21 to J/P64-2 to J/P251, which is the top connector contact on the photoconductor guide rail;
 - P40-18 to J/P 64-3 to P63-1;
 - P40-20 to J/P64-4 to P63-2.

Is there continuity on all?

No: Repair or replace the connectors or wiring that did not have continuity, then turn to TAG 002.

Yes: Replace the photoconductor seam sensor, reconnect J/P40 and J/P63, then turn to TAG 002.

TAG 044: Charge Corona/Transfer Corona Circuit Open

ERROR MESSAGE:MC MAIN/TRANSFER OPEN #044

Possible Defects (not listed in any particular order):

Charge corona

Transfer corona

Connectors or wiring

High voltage power supply

Upper paper guide

Charge corona terminal assembly

VPCL board

-
- 1** Turn the printer off and unplug the power cord.
- Verify that J/P23 and J/P41 are connected properly.
 - Make sure the high voltage power supply charge corona lead is connected properly.
 - Make sure the transfer corona lead is connected properly.
 - Verify that the charge corona and transfer corona ground circuits are connected properly.
 - Remove the transfer corona from the upper paper guide.
 - Clean the transfer corona housing and contacts.
 - Clean the transfer corona wire.
 - Inspect the transfer corona socket in the upper paper guide for contamination.
 - Verify that the transfer corona static eliminator brush on the transfer corona housing is grounded to the transfer corona metal housing.
 - Reinstall the transfer corona.
 - Clean the charge corona contacts.
 - Power-on-reset the printer.
 - Run test prints.

Is error message MC MAIN/TRANSFER OPEN #044 displayed?

No: Loose connectors or a dirty transfer corona were at fault. Turn to TAG 002.

Yes: Continue.

-
- 2** **Has the charge corona been replaced recently?**

No: Continue.

Yes: Go to #4 in this TAG.

-
- 3** Replace the charge corona and photoconductor.

- Power-on-reset the printer.
- Run test prints.

Has the problem been resolved?

No: Reinstall the original charge corona and photoconductor, and continue.

Yes: The charge corona was at fault. Turn to TAG 002.

TAG 044: Charge Corona/Transfer Corona Circuit Open

-
- 4** Remove the transfer corona.
- Inspect the housing for jammed paper.
- Is paper jammed inside the transfer corona housing?**
- No:** Continue.
- Yes:** Remove the jammed paper and check the transfer corona for damage, then turn to TAG 022.
-
- 5** Run diagnostic test “Charge Corona Test” on page 5-9.
- Is error message 046 displayed?**
- No:** Continue.
- Yes:** Go to #11 in this TAG.
-
- 6** Run diagnostic test “Transfer Corona Test” on page 5-9.
- Is error message MC TRANSFER CHRGR OPEN #051 displayed?**
- No:** Continue.
- Yes:** Go to #8 in this TAG.
-
- 7** Run diagnostic test “Transfer Corona Test” on page 5-9.
- Is error message MC TRANSFER CHRGR SHORT #050 displayed?**
- No:** The problem appears to be intermittent. Go to TAG 050.
- Yes:** Go to TAG 050.
-
- 8** Turn the printer off and unplug the power cord.
- Remove the transfer corona.
 - Inspect the transfer corona wire.
- Is the transfer corona wire damaged?**
- No:** Continue.
- Yes:** Replace the transfer corona, then turn to TAG 002.
-
- 9** With the upper paper guide assembly in its fully upright position, check the transfer corona's lower receptacle for continuity to ground.
- Is there continuity?**
- No:** Replace or repair the upper paper guide assembly, then turn to TAG 002.
- Yes:** Continue.
-
- 10** Disconnect high voltage power supply lead to the transfer corona.
- Check the transfer corona's upper receptacle to the lead removed from the high voltage power supply for continuity.
- Is there continuity?**
- No:** Replace the upper paper guide assembly, then turn to TAG 002.
- Yes:** Go to #13 in this TAG.

- 11** Turn the printer off and unplug the power cord.
- Disconnect the charge corona lead from the high voltage power supply.
 - Check for continuity the charge corona lead terminal assembly's lower contact to the lead removed from the high voltage power supply.
- Is there continuity?**
- No:** Repair or replace the charge corona lead or the charge corona terminal assembly, then turn to TAG 002.
- Yes:** Continue.
-

- 12** Remove the cleaner.
- Disconnect J/P85.
 - Check for continuity between the connector for the charge corona terminal assembly's upper contact and J/P85-10 at the high voltage power supply.
- Is there continuity?**
- No:** Repair or replace the connectors or wiring, then turn to TAG 002.
- Yes:** Continue.
-

- 13** Disconnect J/P41 and J/P23.
- Check P41-35 to P23-5 for continuity.
- Is there continuity?**
- No:** Repair or replace the connectors or wiring from P41-35 to P23-5, then turn to TAG 002.
- Yes:** Continue.
-

- 14** Check P41-39 to P23-1 for continuity.
- Is there continuity?**
- No:** Repair or replace the connectors or wiring from P41-39 to P23-1, then turn to TAG 002.
- Yes:** Continue.
-

- 15** Reconnect the power.
- Turn the printer on.
 - Check J/P41-35 for +24 Vdc.
- Is the voltage +24 Vdc?**
- No:** Replace the VPCL board, then turn to TAG 002.
- Yes:** Determine whether the high voltage power supply or the charge corona terminal assembly is at fault, replace the faulty unit, then turn to TAG 002.
-

TAG 045: Charge Corona Circuit Shorted

ERROR MESSAGE:MC MAIN CHARGER SHORT #045

Possible Defects (not listed in any particular order):

Charge corona
High voltage power supply
Charge corona terminal assembly
Connectors or wiring
VPCL board

-
- 1** Turn the printer off and unplug the power cord.
- Verify that J/P23, J/P41, J/P85, P124, P143, and the high voltage power supply charge corona lead are connected properly.
 - Clean the charge corona contacts.
 - Power-on-reset the printer.
 - Run test prints.

Is error message MC MAIN CHARGER SHORT #045 displayed?

No: Loose connectors or dirty contacts were at fault. Turn to TAG 002.

Yes: Continue.

-
- 2** **Has the charge corona been replaced recently?**

No: Continue.

Yes: Go to #4 in this TAG.

-
- 3** Replace the charge corona and photoconductor.

- Run test prints.

Is error message MC MAIN CHARGER SHORT #045 still displayed?

No: The charge corona was at fault. Turn to TAG 002.

Yes: Reinstall the original charge corona and photoconductor, then continue.

-
- 4** Turn the printer off and unplug the power cord.

- Disconnect the charge corona lead from the high voltage power supply.
- Check for continuity the charge corona terminal assembly's lower contact to the lead removed from the high voltage power supply.

Is there continuity?

No: Repair or replace the high voltage lead or the charge corona terminal block, then turn to TAG 002.

Yes: Continue.

5 Reconnect the charge corona high voltage lead.

- Disconnect P23 and J/P41.
- Check J/P41-34 to P23-6 for continuity.

Is there continuity?

No: Repair or replace the connectors or wiring from P41-34 to P23-6, then turn to TAG 002.

Yes: Continue.

6 Check P41-35 to P23-5 for continuity.

Is there continuity?

No: Repair or replace the connectors or wiring from P41-35 to P23-5.

Yes: Replace the high voltage power supply. If this corrects the problem, turn to TAG 002. If this does not correct the problem, replace the VPCL board, then turn to TAG 002.

TAG 047: PC Life Data Error

ERROR MESSAGE:MC PC LIFE DATA ERROR #047

Possible Defects (not listed in any particular order):

Connectors or wiring
Photoconductor
Software
VPCL board

-
- 1** Turn the printer off and unplug the power cord.
- Make sure the photoconductor is properly installed.
 - Clean the photoconductor contacts, the guide rail contacts, and the photoconductor cavity
 - Confirm that the proper photoconductor is installed.
 - Power-on-reset the printer.

Is error message MC PC LIFE DATA ERROR #047 displayed?

No: A loose connector or improper photoconductor were at fault. Turn to TAG 002.

Yes: Continue.

-
- 2** Replace the photoconductor.
- Power-on-reset the printer.
- Is error message MC PC LIFE DATA ERROR #047 displayed?**
- No:** The photoconductor was at fault. Turn to TAG 002.
- Yes:** Replace the VPCL board. If the error persists, repair or replace the wiring between J/P251 (photoconductor contacts) and J/P64 and P40 (VPCL board), then turn to TAG 002.

TAG 048: Developer Life Error

ERROR MESSAGE:MC DEVELOPER LIFE ERROR #048

Possible Defects (not listed in any particular order):

Connectors or wiring
Developer
Software
VPCL board

1 Turn the printer off and unplug the power cord.

- Make sure the developer is properly installed.
- Confirm that the proper developer is installed.
- Power-on-reset the printer.

Is error message MC DEVELOPER LIFE ERROR #048 displayed?

No: A loose connector or improper developer were at fault. Turn to TAG 002.

Yes: Continue.

2 Replace the developer.

- Power-on-reset the printer.

Is error message MC DEVELOPER LIFE ERROR #048 displayed?

No: The developer was at fault. Turn to TAG 002.

Yes: Replace the VPCL board. If the error persists, repair or replace the wiring between P25 (developer) and P40 (VPCL board), then turn to TAG 002.

TAG 050: Transfer Corona Circuit Shorted

ERROR MESSAGE:MC TRANSFER CHRGR SHORT #050

Possible Defects (not listed in any particular order):

Transfer corona
High voltage power supply
Connectors or wiring
VPCL board
Upper paper guide assembly

-
- 1** Turn the printer off and unplug the power cord.
- Verify that J/P23, J/P41 and the transfer corona high voltage power supply lead are connected properly.
 - Power-on-reset the printer.
 - Run test prints.

Is error message MC TRANSFER CHRGR SHORT #050 displayed?

No: A loose connector was at fault. Turn to TAG 002.

Yes: Continue.

-
- 2** Turn the printer off and unplug the power cord.
- Remove and clean the transfer corona housing and contacts.
 - Check between the two terminals on the back of the transfer corona for continuity.

Is there continuity?

No: Continue.

Yes: Repair or replace the transfer corona, then turn to TAG 002.

-
- 3** Reinstall the transfer corona.
- Power-on-reset the printer.
 - Run test prints.

Is error message MC TRANSFER CHRGR SHORT #050 displayed?

No: A dirty transfer corona was at fault. Turn to TAG 002.

Yes: Continue.

-
- 4** Turn the printer off and unplug the power cord.
- Disconnect the transfer corona lead from the high voltage power supply.
 - Check the transfer corona high voltage power supply lead for continuity to ground.

Is there continuity to ground?

No: Continue.

Yes: Repair or replace the upper paper guide assembly or transfer corona, then turn to TAG 002.

5 Reconnect the transfer corona high voltage power supply lead.

- Disconnect J/P23 and J/P41.
- Check P41-37 to P23-3 for continuity.

Is there continuity?

No: Repair or replace the connectors or wiring from P41-37 to P23-3, then turn to TAG 002.

Yes: Continue.

6 Replace the transfer corona.

Has the problem been resolved?

No: Replace the high voltage power supply. If this resolves the problem, turn to TAG 002. If the problem has not been resolved, replace the VPCL board, then turn to TAG 002.

Yes: Turn to TAG 002.

TAG 055: Erase Lamp Malfunction

ERROR MESSAGE:MC ERASER LAMP #055

Possible Defects (not listed in any particular order):

*Erase lamp assembly
Connectors or wiring
VPCL board*

-
- 1** Turn the printer off and unplug the power cord.
- Verify that J/P26, J/P40 are connected properly.
 - Power-on-reset the printer.
- Is error message MC ERASER LAMP #055 displayed?**
- No:** Continue.
- Yes:** Go to #3 in this TAG.
-
- 2** Run diagnostic test [“Erase Lamp Test” on page 5-10.](#)
- Is the value displayed less than 220?**
- No:** A loose connector was at fault. Turn to TAG 002.
- Yes:** Continue.
-
- 3** Run diagnostic test [“Photoconductor Seam Sensor Test” on page 5-8.](#)
- Watch all the LEDs on the erase lamp.
- Do all the LEDs on the erase lamp come on, even momentarily?**
- No:** Continue.
- Yes:** Replace the VPCL board, then turn to TAG 002.
-
- 4** Run diagnostic test [“Photoconductor Seam Sensor Test” on page 5-8.](#)
- Check J/P26-2 for +12 Vdc immediately. After the start of the test, the voltage may drop to 0 Vdc.
- Did you measure +12 Vdc?**
- No:** Continue.
- Yes:** Go to #6 in this TAG.
-
- 5** Turn off the printer and unplug the power cord.
- Disconnect J/P26 and J/P40.
 - Check P26-2 to P40-3 for continuity.
- Is there continuity?**
- No:** Repair or replace the connectors or wiring from P26-2 to P40-3, then turn to TAG 002.
- Yes:** Replace the VPCL board, then turn to TAG 002.

6 Turn off the printer and unplug the power cord.

- Disconnect P26 and P40.
- Check P26-1 to P40-2 for continuity.

Is there continuity?

No: Repair or replace the connectors or wiring from P26-1 to P40-2, then turn to TAG 002.

Yes: Repair or replace the erase lamp assembly. If this resolves the problem, turn to TAG 002. If this does not resolve the problem, replace the VPCL board, turn to TAG 002.

TAG 070: Fuser Malfunction

ERROR MESSAGE:MC FUSER/THERMAL FUSE #070
MC FUSER TEMP TOO LOW #073

Symptoms: *No AC power at the fuser*

Possible Defects (not listed in any particular order):

Fuser
Power control #2 board
AC power supply
DC power supply
Connectors or wiring
VPCL board

! A lack of continuity may result in fuser damage. If this has occurred, replace the fuser when replacing connectors and/or wiring.

1

Turn the printer off and unplug the power cord.

- Verify that J/P44, J/P4, J/P10, J/P11, J/P12, J/P70, J/P40, J/P41, J/P8, and J/P5 (bottom of fuser) are connected properly.
- Verify that the fuser is installed properly.
- Read the following steps before taking further action.
- Power-on-reset the printer.
- Watch through the output tray opening to see if the fuser lamp comes on.

! If the fuser lamp comes on immediately after power on, turn off the printer and replace the AC power supply.

Is error message MC FUSER/THERMAL FUSE #070 or MC FUSER TEMP TOO LOW #073 displayed?

No: A loose connector was at fault. Turn to TAG 002.

Yes: Continue.

2

Has the fuser been replaced recently?

No: Continue.

Yes: Go to #4 in this TAG.

3

Replace the fuser.

- Power-on-reset the printer.
- Watch through the output tray opening to see if the fuser lamp comes on.

! If the fuser lamp comes on immediately after power on, turn off the printer and replace the AC power supply.

Has the problem been resolved?

No: Reinstall the original fuser and continue.

Yes: Turn to TAG 002.

-
- 4** Power-on-reset the printer.
- Watch through the output tray opening to see if the fuser lamp comes on during the first few minutes after power on.
- !** If the fuser lamp comes on immediately after power on, turn the printer off and replace the AC power supply.
- Does the fuser lamp light?**
- No:** Go to [#9](#) in this TAG.
- Yes:** Continue.
-
- 5** Replace the VPCL board.
- Power-on-reset the printer.
- Is error message MC FUSER/THERMAL FUSE #070 or MC FUSER TEMP TOO LOW #073 displayed?**
- No:** Turn to TAG 002.
- Yes:** Replace the VPCL board and continue.
-
- 6** Turn the printer off and unplug the power cord.
- Remove the fuser.
 - Disconnect J/P41.
 - Check P41-22 to P5-6 for continuity.
- Is there continuity?**
- No:** Repair or replace the connectors or wiring from P41-22 to P83-1 or J83-1 to P5-6, then turn to TAG 002.
- Yes:** Continue.
-
- 7** Check P41-21 to P5-7 for continuity.
- Is there continuity?**
- No:** Repair or replace the connectors or wiring from P41- 21 to P83-2 or J83-2 to P5-7, then turn to TAG 002.
- Yes:** Continue.
-
- 8** Reinstall the fuser.
- Check P41-21 to P41-22 for resistance.
- Is the resistance between 1K Ω and 400 K Ω ?**
- No:** The new fuser seems to be defective. Replace it with a new fuser, then turn to TAG 002.
- Yes:** Replace the VPCL board, then turn to TAG 002.
-
- 9** Power-on-reset the printer.
- Check J/P10-2 for +24 Vdc during the 15 seconds following power-on-reset.
- Is the voltage +24 Vdc?**
- No:** Go to [#15](#) in this TAG.
- Yes:** Continue.

TAG 070: Fuser Malfunction

- 10** Turn the printer off.
- Continue to check J/P10-2 for +24 Vdc.
 - Power-on-reset the printer.
- Does the voltage drop from +24 Vdc to 0 Vdc during the first few minutes after power on, while the fuser lamp is on?**
- No:** Go to #23 in this TAG.
Yes: Continue.
-

- 11** Power-on-reset the printer.
- ! Use extreme caution:**
- Check J/P44-1 to J/P44-2 for at least 100 Vac during the first few minutes after power on, while the fuser lamp is on.
- Is the voltage at least 100 Vac?**
- No:** Go to #14 in this TAG.
Yes: Continue.
-

- 12** Turn off the printer.
- Remove the fuser.
 - Clean the contacts of connector J/P5.
 - Disconnect J/P44.
 - Check J44-2 to J5-4 and J44-1 to J5-1 for continuity.
- Is there continuity on both?**
- No:** Repair or replace the connectors or wiring as needed, then turn to TAG 002.
Yes: Continue.
-

- 13** Reinstall the fuser.
- Power-on-reset the printer.
- Has the problem been resolved?**
- No:** Replace the fuser, then turn to TAG 002.
Yes: Cleaning the contacts resolved the problem. Turn to TAG 002.
-

- 14** Power-on-reset the printer.
- ! Use extreme caution:**
- Check J/P4-1 to J/P4-2 for at least 100 Vac during the first few minutes after power on, while the fuser lamp is on.
- Was the voltage at least 100 Vac?**
- No:** Replace the AC power supply, then turn to TAG 002.
Yes: Repair or replace the connectors or wiring from J/P4-1 to J/P44-1, or J/P4-2 to J/P44-2, then turn to TAG 002.
-

- 15** Check J/P10-1 for +24 Vdc.
- Is the voltage +24 Vdc?**
- No:** Continue.
Yes: Go to #18 in this TAG.

-
- 16** Check J/P11-1 for +24 Vdc.
Is the voltage +24 Vdc?
No: Continue.
Yes: Replace power control #2 board, then turn to TAG 002.
-
- 17** Check J/P8-11 for +24 Vdc.
Is the voltage +24 Vdc?
No: Replace the DC power supply, then turn to TAG 002.
Yes: Repair or replace the connectors or wiring from P11-1 to P8-11, then turn to TAG 002.
-
- 18** Turn the printer off and unplug the power cord.
• Disconnect J/P70 and J/P10.
• Check P70-1 to P10-1 for continuity.
Is there continuity?
No: Repair or replace the connectors or wiring from P70-1 to P10-1, then turn to TAG 002.
Yes: Continue.
-
- 19** Check P70-2 and P10-2 for continuity.
Is there continuity?
No: Repair or replace the connectors or wiring from P70-2 to P10-2, then turn to TAG 002.
Yes: Continue.
-
- 20** Reconnect J/P70.
• Connect negative lead of meter to P10-2 and positive lead of meter to P10-1.
Is the resistance approximately 550K Ω ?
No: Replace the AC power supply, then turn to TAG 002.
Yes: Continue.
-
- 21** Disconnect J/P12.
• Check J10-2 (power control #2 board) for continuity to ground.
Is there continuity?
No: Continue.
Yes: Replace the power control #2 board, then turn to TAG 002.
-
- 22** Reconnect J/P10 and J/P12.
• Disconnect J/P40.
• Check P40-36 for continuity to ground.
Is there continuity?
No: Replace the VPCL board, then turn to TAG 002.

23

Replace the VPCL board.

- Continue to check J/P10-2 for +24 Vdc.
- Power-on-reset the printer.

Does the voltage drop from +24 Vdc to 0 Vdc during the first few minutes after power on, while the fuser lamp is on?

No: Reinstall the old VPCL board. Repair or replace the wiring between the fuser and the VPCL board, then turn to TAG 002.

Yes: The VPCL board was at fault, Turn to TAG 002.

TAG 071: Open Fuser/Thermistor

ERROR MESSAGE:MC NO FUSER/THERMISTOR #071

Possible Defects (not listed in any particular order):

Connectors or wiring

Fuser

VPCL board

- 1** Turn the printer off and unplug the power cord.
- Make sure the fuser is installed properly.
 - Confirm that J/P41 and J/P44 are connected properly.

Has the fuser been replaced recently?

No: Continue.

Yes: Go to #3 in this TAG.

- 2** Replace the fuser.
- Power-on-reset the printer.
- Is error message MC NO FUSER/THERMISTOR #071 displayed during power-on-reset?**

No: The fuser was at fault. Turn to TAG 002.

Yes: Reinstall the original fuser and continue.

- 3** Turn the printer off and unplug the power cord.
- Disconnect J/P41.
 - Remove the fuser.
 - Check P41-21 to P5-7 and P41-22 to P5-6 for continuity.

Is there continuity on both?

No: Repair or replace the connectors or wiring as necessary, then turn to TAG 002.

Yes: Continue.

- 4** Check P41-21 and P41-22 for continuity to ground.

Is there continuity to ground on either?

No: Replace the fuser. If this resolves the problem, then turn to TAG 002. If this does not resolve the problem, replace the VPCL board, then turn to TAG 002.

Yes: Repair or replace the connectors or wiring that have continuity to ground:

P41-21 to P44-2, J44-2 to P5-7, or

P41-22 to P44-1, J44-1 to P5-6;

then turn to TAG 002.

TAG 072: Fuser Temperature Too High

ERROR MESSAGE:MC FUSER TEMP TOO HIGH #072

Possible Defects (not listed in any particular order):

Connectors or wiring

Fuser

AC power supply

VPCL board

! The conditions that cause error message **MC FUSER TEMP TOO HIGH #072** often cause the fuser's thermal fuse to open. This usually necessitates replacement of the fuser.

1

Turn the printer off and unplug the power cord.

- Verify that J/P44, J/P40, J/P10, J/P70, and J/P8 are connected properly.
- Make sure the fuser is properly installed.
- Read the following steps before taking further actions.
- Power-on-reset the printer.
- Watch through the output tray opening to see if the fuser lamp comes on.

! If the fuser lamp comes on immediately after power on, turn off the printer and replace the AC power supply.

- Run test prints.

Has the problem been resolved?

No: Continue.

Yes: A loose connector was at fault. Turn to TAG 002.

2

Has the fuser been replaced recently?

No: Continue.

Yes: Go to #4 in this TAG.

3

Replace the fuser.

- Power-on-reset the printer.
- Watch through the output tray opening to see if the fuser lamp comes on during the first few minutes after power on.

! If the fuser lamp comes on immediately after power on, turn off the printer and replace the AC power supply.

Has the problem been resolved?

No: Reinstall the original fuser and continue.

Yes: The fuser was at fault. Turn to TAG 002.

4

Power-on-reset the printer.

- Watch the fuser's lamp.

Does the lamp turn on before error message MC FUSER TEMP TOO HIGH #072 is displayed?

No: Replace the VPCL board, then turn to TAG 002.

Yes: Continue.

-
- 5** Turn the printer off and unplug the power cord.
- Disconnect J/P41.
 - Check P41-21 for continuity to ground.
- Is there continuity?**
- No:** Continue.
- Yes:** Repair or replace the connectors or wiring that have continuity to ground: P41-21 to P44-2, or J44-2 to P5-7; then turn to TAG 002.

-
- 6** Check P41-21 to P41-22 for resistance.
- Is the resistance at least 1K Ω ?**
- No:** Continue.
- Yes:** Replace the VPCL board, then turn to TAG 002.

-
- 7** Remove the fuser.
- Check P41-21 to P5-7 for resistance.
- Is there resistance?**
- No:** Continue.
- Yes:** Repair or replace the connectors or wiring that have resistance: P41-21 to P44-2, or J44-2 to P5-7; then turn to TAG 002.

-
- 8** Check P41-22 to P5-6 for resistance.
- Is there resistance?**
- No:** Replace the fuser, then turn to TAG 002.
- Yes:** Repair or replace the connectors or wiring that have resistance: P41-22 to P44-1, or J44-1 to P5-6; then turn to TAG 002.
-

TAG 097: +12 Vdc Power Shorted or Sensing Problem

ERROR MESSAGE:MC +12 DC POWER FAILURE #097

Possible Defects (not listed in any particular order):

DC power supply
Connectors or wiring
IO card
RIGS board
Optional external attachment
Power control #2 board
Power control #3 board
Developer
Paper timing sensor
Upper paper empty sensor
Lower paper empty sensor
Output tray full sensor
Paper exit sensor
Tray front sensor
Tray rear sensor
Erase lamp
VPCL board

Duplex control board #1
Duplex control board #2
Paper path sensor
Cover open sensor
Restart side sensor
Restart paper sensor

-
- 1** Turn off the printer and unplug the power cord.
- Verify that J/P303, J/P331, J/P323, J/P305, J/P310, J/P306, J/P32, and J/P33 are connected properly.
 - Power-on-reset the printer.

Has the problem been resolved?

No: Continue.

Yes: Loose connectors were at fault. Turn to TAG 002.

-
- 2** Check J/P8-6 for +12 Vdc.
- Is the voltage +12 Vdc?**
- No:** Continue.
- Yes:** Replace the VPCL board, then turn to TAG 002.

-
- 3** Turn the printer off.
- Disconnect J/P330.
 - Turn the printer on.
 - Check J/P8-6 for +12 Vdc.
- Is the voltage +12 Vdc?**
- No:** Continue.
- Yes:** Go to [#35](#) in this TAG.

-
- 4** Turn the printer off.
- Disconnect J/P32.
 - Turn the printer on.
 - Check J/P8-6 for +12 Vdc.

Is the voltage +12 Vdc?

No: Go to #8 in this TAG.

Yes: Continue.

- 5** Turn the printer off.
- Reconnect J/P32.
 - Disconnect J/P74.
 - Turn the printer on.
 - Check J/P8-6 for +12 Vdc.

Is the voltage +12 Vdc?

No: Replace the RIGS board, then turn to TAG 002.

Yes: Continue.

- 6** Turn the printer off.
- Remove any IO cards.
 - Check J/P8-6 for +12 Vdc.

Is the voltage +12 Vdc?

No: Replace the IO card(s) and continue.

Yes: Replace the IO card(s), then turn to TAG 002.

- 7** Turn the printer off.
- Reconnect J/P74.
 - Disconnect the DC cable (J/P73) for the attachment option.
 - Check J/P8-6 for +12 Vdc.

Is the voltage +12 Vdc?

No: Replace the signal interface board, then turn to TAG 002.

Yes: Replace the attachment option, then turn to TAG 002.

- 8** Turn the printer off.
- Reconnect J/P32.
 - Disconnect J/P91.
 - Turn the printer on.
 - Check J/P8-6 for +12 Vdc.

Is the voltage +12 Vdc?

No: Go to #13 in this TAG.

Yes: Continue.

TAG 097: +12 Vdc Power Shorted or Sensing Problem

- 9** Turn the printer off.
- Reconnect J/P91.
 - Disconnect J/P40 and J/P41.
 - Turn the printer on.
 - Check J/P8-6 for +12 Vdc.
- Is the voltage +12 Vdc?**
- No:** Replace the VPCL board, then turn to TAG 002.
- Yes:** Continue.
-

- 10** Turn the printer off.
- Reconnect J/P40.
 - Turn the printer on.
 - Check J/P8-6 for +12 Vdc.
- Is the voltage +12 Vdc?**
- No:** Go to #15 in this TAG.
- Yes:** Continue.
-

- 11** Turn the printer off.
- Reconnect J/P41.
 - Remove the developer.
 - Turn the printer on.
 - Check J/P8-6 for +12 Vdc.
- Is the voltage +12 Vdc?**
- No:** Continue.
- Yes:** Replace the developer, then turn to TAG 002.
-

- 12** Turn the printer off and unplug the power cord.
- Disconnect J/P41.
 - Remove the fuser.
 - Check P41-49 to P25-4 and P41-50 to P25-1 for continuity to ground.
- Is there continuity?**
- No:** Go to #15 in this TAG.
- Yes:** Repair or replace the appropriate connectors or wiring, then turn to TAG 002.
-

- 13** Turn the printer off and unplug the power cord.
- Reconnect J/P91.
 - Disconnect J/P8 and J/P32.
 - Check J8-6 for continuity to ground.
- Is there continuity?**
- No:** Continue.
- Yes:** Repair or replace the connectors or wiring from P8-6 to P32-10 to P91-3, then turn to TAG 002.

- 14** Reconnect J/P32 and J/P8.
- Disconnect J/P77.
 - Turn on the printer.
 - Check J/P8-3 for +12Vdc.

Is the voltage +12 Vdc?

No: Replace the DC power supply, then turn to TAG 002.

Yes: Replace the disk drive assembly, then turn to TAG 002.

- 15** Turn the printer off.
- Reconnect J/P41.
 - Disconnect J/P58, J/P60, and J/P62.
 - Turn the printer on.
 - Check J/P8-6 for +12 Vdc.

Is the voltage +12 Vdc?

No: Go to #21 in this TAG.

Yes: Continue.

- 16** Turn the printer off.
- Reconnect J/P58.
 - Turn on the printer.
 - Check J/P8-6 for +12 Vdc.

Is the voltage +12 Vdc?

No: Go to #19 in this TAG.

Yes: Continue.

- 17** Turn the printer off.
- Reconnect J/P60.
 - Turn the printer on.
 - Check J/P8-6 for +12 Vdc.

Is the voltage +12 Vdc?

No: Go to #20 in this TAG.

Yes: Continue.

- 18** Disconnect J/P61.
- Check P62-1 to P61-1 for continuity to ground.

Is there continuity?

No: Replace the lower paper empty sensor, then turn to TAG 002.

Yes: Repair or replace the connectors or wiring from P62-1 to P61-1, then turn to TAG 002.

TAG 097: +12 Vdc Power Shorted or Sensing Problem

- 19** Disconnect J/P58 and J/P57.
- Check P58-1 to P57-1 for continuity to ground.
- Is there continuity?**
- No:** Replace the paper timing sensor.
- Yes:** Repair or replace the connectors or wiring from P58-1 to P57-1, then turn to TAG 002.
-

- 20** Disconnect J/P60 and J/P59.
- Check P60-1 to P59-1 for continuity to ground.
- Is there continuity?**
- No:** Replace the upper paper empty sensor.
- Yes:** Repair or replace the connectors or wiring from P60-1 to P59-1, then turn to TAG 002.
-

- 21** Turn the printer off and unplug the power cord.
- Disconnect J/P40.
 - Check for continuity to ground:
 - P40-25 to J58-1,
 - P40-25 to J60-1, and
 - P40-25 to J62-1.
- Is there continuity?**
- No:** Continue.
- Yes:** Repair or replace the connectors or wiring from
 - P40-25 to J58-1,
 - P40-25 to J60-1, or
 - P40-25 to J62-1,then turn to TAG 002.
-

- 22** Turn the printer off.
- Reconnect J/P40, J/P58, J/P60, and J/P62.
 - Disconnect J/P50 and J/P54.
 - Turn the printer on.
 - Check J/P8-6 for +12 Vdc.
- Is the voltage +12 Vdc?**
- No:** Go to [#30](#) in this TAG.
- Yes:** Continue.
-

- 23** Turn the printer off.
- Reconnect J/P50.
 - Turn the printer on.
 - Check J/P8-6 for +12 Vdc.
- Is the voltage +12 Vdc?**
- No:** Go to [#27](#) in this TAG.
- Yes:** Continue.

-
- 24** Turn the printer off.
- Reconnect J/P54.
 - Disconnect J/P53.
 - Turn the printer on.
 - Check J/P8-6 for +12 Vdc.
- Is the voltage +12 Vdc?**
- No:** Continue.
- Yes:** Replace the front tray sensor, then turn to TAG 002.

-
- 25** Turn the printer off.
- Disconnect J/P55.
 - Turn the printer on.
 - Check J/P8-6 for +12 Vdc.
- Is the voltage +12 Vdc?**
- No:** Continue.
- Yes:** Replace the rear tray sensor, then turn to TAG 002.

-
- 26** Turn the printer off and unplug the power cord.
- Disconnect J/P54.
 - Check J54-1 and J54-4 for continuity to ground.
- Is there continuity to ground at either?**
- No:** You have failed to isolate the problem. Return to the beginning of this TAG.
- Yes:** Repair or replace the connectors or wiring from:
J54-1 to P53-1 or
J54-4 to P55-1,
then turn to TAG 002.

-
- 27** Turn the printer off.
- Remove the exit cover.
 - Disconnect J/P49 and J/P51.
 - Turn the printer on.
 - Check J/P8-6 for +12 Vdc.
- Is the voltage +12 Vdc?**
- No:** Go to #29 in this TAG.
- Yes:** Continue.

-
- 28** Turn the printer off.
- Reconnect J/P49.
 - Turn the printer on.
 - Check J/P8-6 for +12 Vdc.
- Is the voltage +12 Vdc?**
- No:** Replace the paper exit sensor, then turn to TAG 002.
- Yes:** Replace the output tray full sensor, then turn to TAG 002.

TAG 097: +12 Vdc Power Shorted or Sensing Problem

- 29** Turn the printer off and unplug the power cord.
- Disconnect J/P50.
 - Check J50-1 and J50-4 for continuity to ground.

Is there continuity at either?

No: You have failed to isolate the problem. Return to the beginning of this TAG.

Yes: Repair or replace the connectors or wiring from:
J50-1 to P49-1 or
J50-4 To P51-1,
then turn to TAG 002.

- 30** Turn the printer off.
- Disconnect J/P40.
 - Check P40-26 for continuity to ground.

Is there continuity to ground?

No: Continue.

Yes: Repair or replace the connectors or wiring from:
P40-26 to P54-1,
P40-26 to P54-4,
P40-26 to P50-1, or
P40-26 to P50-4,
then turn to TAG 002

- 31** Turn the printer off.
- Reconnect J/P40, J/P50, and J/P54.
 - Disconnect J/P12.
 - Turn the printer on.
 - Check J/P8-6 for +12 Vdc.

Is the voltage +12 Vdc?

No: Continue.

Yes: Replace the power control #2 board, then turn to TAG 002.

- 32** Turn the printer off and unplug the power cord.
- Disconnect J/P40.
 - Check P40-34 to P12-8 for continuity to ground.

Is there continuity?

No: Continue.

Yes: Repair or replace the connectors or wiring from P40-34 to P12-8, then turn to TAG 002.

- 33** Reconnect J/P40 and J/P12.
- Disconnect J/P102.
 - Turn on the printer.
 - Check J/P8-6 for +12 Vdc.

Is the voltage +12 Vdc?

No: Continue.

Yes: Replace the power control #3 board, then turn to TAG 002.

-
- 34** Turn off the printer and unplug the power cord.
- Disconnect J/P40.
 - Check P40-35 to P102-1 for continuity to ground.

Is there continuity?

No: You have failed to isolate the problem. Return to the beginning of this TAG.

Yes: Repair or replace the connectors or wiring from P40-35 to P102-1, then turn to TAG 002.

- 35** Turn off the printer.
- Reconnect J/P330.
 - Disconnect J/P323.
 - Turn on the printer.
 - Check J/P330-2 for +12 Vdc.

Is the voltage +12 Vdc?

No: Go to [#40](#) in this TAG.

Yes: Continue.

- 36** Turn off the printer.
- Reconnect J/P323.
 - Disconnect J/P305.
 - Turn on the printer.
 - Check J/P330-2 for +12Vdc.

Is the voltage +12 Vdc?

No: Go to [#39](#) in this TAG.

Yes: Continue.

- 37** Turn off the printer.
- Reconnect J/P305.
 - Disconnect J/P310 (inside the duplex tray).
 - Turn on the printer.
 - Check J/P330-2 for +12 Vdc.

Is the voltage +12 Vdc?

No: Continue.

Yes: Go to [#42](#) in this TAG.

- 38** Turn the printer off and unplug the power cord.
- Disconnect J/P305.
 - Check P305-2 and P310-2 for continuity to ground.

Is there continuity?

No: Return to the beginning of this TAG and start again.

Yes: Repair or replace connectors or wiring P305-2 to P310-2, then turn to TAG 002.

TAG 097: +12 Vdc Power Shorted or Sensing Problem

- 39** Turn off the printer and unplug the power cord.
- Disconnect J/P323.
 - Check J323-2 and J305-2 for continuity to ground.
- Is there continuity at either?**
- No:** Return to the beginning of this TAG and start again.
- Yes:** Repair or replace the connectors or wiring from J323-2 to J305-2, then turn to TAG 002.
-

- 40** Turn off the printer.
- Reconnect J/P323.
 - Disconnect J/P306.
 - Turn on the printer.
 - Check J/P330-2 for +12 Vdc.
- Is the voltage +12 Vdc?**
- No:** Continue.
- Yes:** Go to #45 in this TAG.
-

- 41** Turn off the printer and unplug the power cord.
- Disconnect J/P331.
 - Check J331-2 to P306-2 for continuity to ground.
- Is there continuity?**
- No:** Repair or replace the connectors or wiring from:
P330-2 to P331-2, or
P330-2 to P323-2.
- Yes:** Repair or replace the connectors or wiring from J331-2 to P306-2.
-

- 42** Turn off the printer.
- Reconnect J/P310.
 - Disconnect J/P320 and J/P322.
 - Turn on the printer.
 - Check J/P330-2 for +12 Vdc.
- Is the voltage +12 Vdc?**
- No:** Continue.
- Yes:** Go to #44 in this TAG.
-

- 43** Turn off the printer and unplug the power cord.
- Disconnect J/P312.
 - Check for continuity to ground:
P312-1 to P320-1, and
P312-4 to P322-1
- Is there continuity?**
- No:** Replace the duplex control board #2, then turn to TAG 002.
- Yes:** Repair or replace the connectors or wiring from P312-1 to P320-1, or P312-4 to P322-1, then turn to TAG 002.

- 44** Turn off the printer.
- Reconnect J/P320.
 - Turn on the printer.
 - Check J/P330-2 for +12 Vdc.

Is the voltage +12 Vdc?

No: Replace the restart side sensor, then turn to TAG 002.

Yes: Replace the restart paper sensor, then turn to TAG 002.

- 45** Turn off the printer.
- Reconnect J/P306.
 - Disconnect J/P319 and J/P318.
 - Turn on the printer.
 - Check J/P330-2 for +12 Vdc.

Is the voltage +12 Vdc?

No: Go to [#47](#) in this TAG.

Yes: Continue.

- 46** Turn off the printer.
- Reconnect J/P319.
 - Turn on the printer.
 - Check J/P330-2 for +12 Vdc.

Is the voltage at +12 Vdc?

No: Replace the paper path sensor, then turn to TAG 002.

Yes: Replace the cover open sensor, then turn to TAG 002.

- 47** Turn off the printer and unplug the power cord.
- Disconnect J/P309.
 - Check for continuity to ground:
P309-4 to P319-1, and
P309-3 to P318-1.

Is there continuity at either?

No: Replace the duplex control board #1, then turn to TAG 002.

Yes: Repair or replace the connectors or wiring from:
P309-4 to P319-1, or
P309-3 to P318-1;
then turn to TAG 002.

TAG 098: -12 Vdc Power Shorted

ERROR MESSAGE:MC -12 DC POWER FAILURE #098

Possible Defects (not listed in any particular order):

Connectors or wiring
DC power supply
VPCL board
RIGS board
IO card
External attachment option

-
- 1** Turn the printer off and unplug the power cord.
- Verify that J/P8, J/P32, J/P33, J/P73, and J/P74 are connected properly.
 - Power-on-reset the printer.

Has the problem been resolved?

No: Continue.

Yes: Loose connectors were at fault. Turn to TAG 002.

-
- 2** Check J/P32-3 for -12 Vdc.

Is the voltage -12 Vdc?

No: Continue.

Yes: Replace VPCL board, then turn to TAG 002.

-
- 3** Turn the printer off.
- Disconnect J/P32.
 - Turn the printer on.
 - Check J/P8-8 for -12 Vdc.

Is the voltage -12 Vdc?

No: Continue.

Yes: Go to #5 in this TAG.

-
- 4** Turn the printer off.
- Disconnect J/P8.
 - Check P8-8 to P32-3 for continuity to ground.

Is there continuity?

No: Replace the DC power supply, then turn to TAG 002.

Yes: Repair or replace the connectors or wiring from P8-8 to P32-3.

-
- 5** Turn the printer off.
- Reconnect J/P32.
 - Disconnect J/P74.
 - Turn the printer on.
 - Check J/P8-8 for -12 Vdc.
- Is the voltage -12 Vdc?**
- No:** Replace the RIGS board, then turn to TAG 002.
- Yes:** Continue.

-
- 6** Turn the printer off.
- Remove any IO cards.
 - Check J/P8-8 for -12 Vdc.
- Is the voltage -12 Vdc?**
- No:** Replace the IO card(s) and continue.
- Yes:** Replace the IO card(s), then turn to TAG 002.

-
- 7** Turn the printer off.
- Reconnect J/P74.
 - Disconnect the DC cable (J/P73) for the attachment option.
 - Turn the printer on.
- Is the voltage at J/P8-8 -12 Vdc?**
- No:** Replace the signal interface board, then turn to TAG 002.
- Yes:** Replace the attachment option, then turn to TAG 002.
-

TAG 099: +24 Vdc Power Shorted

ERROR MESSAGE:MC +24 DC POWER FAILURE #099

Possible Defects (not listed in any particular order):

| | |
|----------------------------------|--------------------------------|
| <i>DC power supply</i> | <i>IO card</i> |
| <i>AC power supply</i> | <i>Duplex control board #1</i> |
| <i>Connectors or wiring</i> | <i>Duplex control board #2</i> |
| <i>VPCL board</i> | <i>Route motor</i> |
| <i>RIGS board</i> | <i>In solenoid</i> |
| <i>Power control #2 board</i> | <i>“C” roller solenoid</i> |
| <i>High voltage power supply</i> | <i>“A” roller clutch</i> |
| <i>Paper timing clutch</i> | <i>Exit solenoid</i> |
| <i>Upper feed roller clutch</i> | <i>Restart motor</i> |
| <i>Upper pick-up clutch</i> | |
| <i>Lower pick-up clutch</i> | |
| <i>Lower feed roller clutch</i> | |
| <i>Counter assembly</i> | |

-
- 1** Turn the printer off and unplug the power cord.
- Verify that J/P11, J/P8, J/P32, J/P33, J/P91, J/P303, J/P305, J/P306, J/P310, J/P323, and J/P331 are connected properly.
 - Power-on-reset the printer.

Has the problem been resolved?

No: Continue.

Yes: A loose connector was at fault. Turn to TAG 002.

- 2** Check J/P8-11 for +24 Vdc.
- Is the voltage +24 Vdc?**
- No:** Continue.
- Yes:** Replace the VPCL board, then turn to TAG 002.
-

- 3** Turn the printer off.
- Remove any IO cards.
 - Check J/P8-11 for +24 Vdc.
- Is the voltage +24 Vdc?**
- No:** Replace the IO card(s) and continue.
- Yes:** Replace the IO card(s), then turn to TAG 002.
-

- 4** Turn the printer off.
- Disconnect J/P330.
 - Turn the printer on.
 - Check J/P8-11 for +24 Vdc.
- Is the voltage +24 Vdc?**
- No:** Continue.
- Yes:** Go to [#23](#) in this TAG.

-
- 5** Turn the printer off.
- Reconnect J/P330.
 - Disconnect J/P11.
 - Turn the printer on.
 - Check J/P8-11 for +24 Vdc.

Is the voltage +24 Vdc?

No: Go to #12 in this TAG.

Yes: Continue.

- 6** Turn the printer off.
- Reconnect J/P11.
 - Disconnect J/P10.
 - Turn the printer on.
 - Check J/P8-11 for +24 Vdc.

Is the voltage +24 Vdc?

No: Go to #8 in this TAG.

Yes: Continue.

- 7** Turn the printer off.
- Reconnect J/P10.
 - Disconnect J/P70.
 - Turn the printer on.
 - Check J/P8-11 for +24 Vdc.

Is the voltage +24 Vdc?

No: Repair or replace the connectors or wiring from P10 to P70, then turn to TAG 002.

Yes: Replace the AC power supply, then turn to TAG 002.

- 8** Turn the printer off.
- Reconnect J/P10.
 - Disconnect J/P12.
 - Turn the printer on.
 - Check J/P8-11 for +24 Vdc.

Is the voltage +24 Vdc?

No: Replace the power control #2 board, then turn to TAG 002.

Yes: Continue.

TAG 099: +24 Vdc Power Shorted

- 9** Turn the printer off.
- Reconnect J/P12.
 - Disconnect J/P41.
 - Turn the printer on.
 - Check J/P8-11 for +24 Vdc.

Is the voltage +24 Vdc?

No: Replace the VPCL board, then turn to TAG 002.

Yes: Continue.

- 10** Turn the printer off.
- Reconnect J/P41.
 - Disconnect J/P23.
 - Turn the printer on.
 - Check J/P8-11 for +24 Vdc.

Is the voltage +24 Vdc?

No: Continue.

Yes: Replace the high voltage power supply, then turn to TAG 002.

- 11** Turn off the printer and unplug the power cord.
- Disconnect J/P41.
 - Check P41-35 to P23-5 for continuity to ground.

Is there continuity?

No: You have failed to isolate the problem. Return to the beginning of this TAG.

Yes: Repair or replace the connectors or wiring from P41-35 to P23-5, then turn to TAG 002.

- 12** Turn the printer off.
- Reconnect J/P11.
 - Disconnect J/P91.
 - Turn the printer on.
 - Check J/P8-13 for +24 Vdc.

Is the voltage +24 Vdc?

No: Go to [#22](#) in this TAG.

Yes: Continue.

- 13** Turn the printer off.
- Reconnect J/P91.
 - Disconnect J/P40 and J/P41.
 - Turn the printer on.
 - Check J/P8-13 for +24 Vdc.

Is the voltage +24 Vdc?

No: Replace the VPCL board, then turn to TAG 002.

Yes: Continue.

-
- 14** Turn the printer off.
- Reconnect J/P40.
 - Turn the printer on.
 - Check J/P8-13 for +24 Vdc.

Is the voltage +24 Vdc?

No: Go to #17 in this TAG.

Yes: Continue.

- 15** Turn the printer off.
- Reconnect J/P41.
 - Disconnect J/P81.
 - Turn the printer on.
 - Check J/P8-13 for +24 Vdc.

Is the voltage +24 Vdc?

No: Repair or replace the connectors or wiring from P41-26 to P81-1, then turn to TAG 002.

Yes: Continue.

- 16** Turn the printer off.
- Reconnect J/P81.
 - Disconnect J/P82.
 - Turn the printer on.
 - Check J/P8-13 for +24 Vdc.

Is the voltage +24 Vdc?

No: Repair or replace the connectors or wiring from J81-1 to P82-1, then turn to TAG 002.

Yes: Replace the counter assembly, then turn to TAG 002.

- 17** Turn the printer off.
- Reconnect J/P41.
 - Disconnect J/P69.
 - Turn the printer on.
 - Check J/P8-13 for +24 Vdc.

Is the voltage +24 Vdc?

No: Continue.

Yes: Replace the lower pick-up roller assembly, then turn to TAG 002.

- 18** Turn the printer off.
- Reconnect J/P69.
 - Disconnect J/P65.
 - Turn the printer on.
 - Check J/P8-13 for +24 Vdc.

Is the voltage +24 Vdc?

No: Continue.

Yes: Replace the paper timing roller assembly, then turn to TAG 002.

- 19** Turn the printer off.
- Reconnect J/P65.
 - Disconnect J/P66.
 - Turn the printer on.
 - Check J/P8-13 for +24 Vdc.

Is the voltage +24 Vdc?

No: Continue.

Yes: Replace the upper feed roller assembly, then turn to TAG 002.

- 20** Turn the printer off.
- Reconnect J/P66.
 - Disconnect J/P67.
 - Turn the printer on.
 - Check J/P8-13 for +24 Vdc.

Is the voltage +24 Vdc?

No: Continue.

Yes: Replace the lower feed roller assembly, then turn to TAG 002.

- 21** Turn the printer off.
- Reconnect J/P67.
 - Disconnect J/P68.
 - Turn the printer on.
 - Check J/P8-13 for +24 Vdc.

Is the voltage +24 Vdc?

No: Repair or replace the connectors or wiring from:

P40-10 to J69-1,
P40-11 to J65-1,
P40-11 to J66-1,
P40-11 to J67-1, or
P40-11 to J 68-1;
then turn to TAG 002.

Yes: Replace the upper pick-up roller assembly, then turn to TAG 002.

- 22** Turn the printer off and unplug the power cord.
- Disconnect J/P8, J/P11, and J/P91.
 - Check P8-11 to P11-1 and P8-13 to P91-1 for continuity to ground.

Is there continuity?

No: Replace the DC power supply, then turn to TAG 002.

Yes: Repair or replace the connectors or wiring from:

P8-13 to P91-1, or
P8-11 to P11-1;
then turn to TAG 002.

-
- 23** Turn the printer off.
- Reconnect J/P330.
 - Disconnect J/P323.
 - Turn the printer on.
 - Check J/P330-1 for +24 Vdc.

Is the voltage +24 Vdc?

No: Go to #27 in this TAG.

Yes: Continue.

- 24** Turn the printer off.
- Reconnect J/P323.
 - Disconnect J/P305.
 - Turn the printer on.
 - Check J/P330-1 for +24 Vdc.

Is the voltage +24 Vdc?

No: Go to #25 in this TAG.

Yes: Continue.

- 25** Turn the printer off.
- Reconnect J/P305.
 - Disconnect J/P310 (inside duplex tray).
 - Turn the printer on.
 - Check J/P330-1 for +24 Vdc.

Is the voltage +24 Vdc?

No: Continue.

Yes: Go to #30 in this TAG.

- 26** Turn the printer off and unplug the power cord.
- Disconnect J/P305.
 - Check P305-1 and P310-1 for continuity to ground.

Is there continuity?

No: Return to the beginning of this TAG and start again.

Yes: Repair or replace the connectors or wiring from P305-1 to P310-1, then turn to TAG 002.

- 27** Turn the printer off and unplug the power cord.
- Disconnect J/P323.
 - Check J323-1 and J305-1 for continuity to ground.

Is there continuity?

No: Return to the beginning of this TAG and start again.

Yes: Repair or replace the connectors or wiring from J323-1 to J305-1-1, then turn to TAG 002.

- 28** Turn the printer off.
- Reconnect J/P323.
 - Disconnect J/P306.
 - Turn the printer on.
 - Check J/P330-1 for +24 Vdc.

Is the voltage +24 Vdc?

No: Continue.

Yes: Go to #32 in this TAG.

- 29** Turn the printer off and unplug the power cord.
- Disconnect J/P331.
 - Check J331-1 and P306-1 for continuity to ground.

Is there continuity?

No: Repair or replace the connectors or wiring from:
P330-1 to P331-1 or
P330-1 to P323-1;
then turn to TAG 002.

Yes: Repair or replace the connectors or wiring from P331-1 to P306-1, then turn to TAG 002.

- 30** Turn the printer off.
- Reconnect J/P310.
 - Disconnect J/P321.
 - Turn the printer on.
 - Check J/P330-1 for +24 Vdc.

Is the voltage +24 Vdc?

No: Continue.

Yes: Replace the restart motor, then turn to TAG 002.

- 31** Turn the printer off.
- Reconnect J/P321.
 - Disconnect J/P312.
 - Turn the printer on.
 - Check J/P330-1 for +24 Vdc.

Is the voltage +24 Vdc?

No: Repair or replace the connectors or wiring from P312 to J321, then turn to TAG 002.

Yes: Replace the duplex control board #2, then turn to TAG 002.

-
- 32** Turn the printer off.
- Reconnect J/P306.
 - Disconnect J/P313.
 - Turn the printer on.
 - Check J/P330-1 for +24 Vdc.
- Is the voltage +24 Vdc?**
- No:** Continue.
- Yes:** Replace the route motor, then turn to TAG 002.
-

- 33** Turn the printer off.
- Reconnect J/P313.
 - Disconnect J/P314.
 - Turn the printer on.
 - Check J/P330-1 for +24 Vdc.
- Is the voltage +24 Vdc?**
- No:** Continue.
- Yes:** Replace the “in” solenoid, then turn to TAG 002.
-

- 34** Turn the printer off.
- Reconnect J/P314.
 - Disconnect J/P315.
 - Turn the printer on.
 - Check J/P330-1 for +24 Vdc.
- Is the voltage +24 Vdc?**
- No:** Continue.
- Yes:** Replace the “C” roller solenoid, then turn to TAG 002.
-

- 35** Turn the printer off.
- Reconnect J/P315.
 - Disconnect J/P316.
 - Turn the printer on.
 - Check J/P330-1 for +24 Vdc.
- Is the voltage +24 Vdc?**
- No:** Continue.
- Yes:** Replace the “A” roller clutch, then turn to TAG 002.
-

- 36** Turn the printer off.
- Reconnect J/P316.
 - Disconnect J/P317.
 - Turn the printer on.
 - Check J/P330-1 for +24 Vdc.
- Is the voltage +24 Vdc?**
- No:** Continue.
- Yes:** Replace the exit solenoid, then turn to TAG 002.
-

- 37** Turn the printer off.
- Reconnect J/P317.
 - Disconnect J/P308 and J/P309.
 - Turn the printer on.
 - Check J/P330-1 for +24 Vdc.

Is the voltage +24 Vdc?

No: Replace the duplex control board #1, then turn to TAG 002.

Yes: Repair or replace the connectors or wiring from:

P309-7~10 to J313-1~4,
P308-1 to J314-1,
P308-2 to J315-1,
P308-3 to J316-1, or
P308-4 to P317-1;
then turn to TAG 002.

TAG 100: VPCL Board Interface Malfunction

ERROR MESSAGE:130, 132, 140, 145, 160-162, 170-172, 180-182

Symptoms: *VPCL board failure*

Possible Defects (not listed in any particular order):
Connectors or wiring
VPCL board

-
- 1** Turn off the printer and unplug the power cord.
- Verify that J/P40, J/P41, J/P33, and J/P91 are connected properly.
 - Power-on-reset the printer.

Has the problem been resolved?

No: Continue.

Yes: A loose connector was at fault. Turn to TAG 002.

- 2** **Was an error message displayed during the power-on-reset?**

No: Refer to the mechanical malfunctions cross-reference chart in [Section 2, TAG Cross-Reference Tables](#).

Yes: Continue.

- 3** **Was the error message the same as the one used to enter this TAG?**

No: Refer to the error message cross-reference chart in [Section 2, TAG Cross-Reference Tables](#).

Yes: Replace the VPCL board, then turn to TAG 002.

TAG 130: Disk Drive Malfunction

ERROR MESSAGE:130, 131, 133, 134

MC INCORRECT DISKETTE #450

MC FLOPPY FORMAT #451

MC WRITE PROTECTED #572 to MC FDC READ #576

MC FDC/DMAC OPERATIONS #586

Symptoms: *Test prints do not run*

Possible Defects (not listed in any particular order):

Diskette

Disk drive assembly

Connectors or wiring

VPCL board

RIGS board

DC power supply

- ! Electrical problems on wires J/P31 to J/P79 and J/P31 to ground may cause diskette and disk drive malfunctions. If this TAG does not correct the problem, suspect an intermittent failure from the disk drive to the RIGS board cable and replace the cable from J/P31 to J/P79 to J/P30.
- ! The causes of error message **MC FDC RESTORE #574** or **MC FDC READ #576** can alter the information on a diskette. You may have to replace the diskette with another known to be good.

1

Turn off the printer.

- Verify that J/P8, J/P77, J/P79, and J/P31 are connected properly.
- Power-on-reset the printer.

Has the problem been resolved?

No: Continue.

Yes: Loose connectors were at fault. Turn to TAG 002.

2

Is error message MC FLOPPY FORMAT #451 displayed?

No: Go to #5 in this TAG.

Yes: Continue.

3

Power-on-reset the printer.

Is error message MC FLOPPY FORMAT #451 still displayed?

No: Go to #5 in this TAG.

Yes: Continue.

4

Remove any diskette from the printer's disk drive assembly.

- Power-on-reset the printer.

Is error message MC FLOPPY FORMAT #451 still displayed?

No: The diskette was at fault. Turn to TAG 002.

Yes: Replace the disk drive assembly and reload the printer's software onto the hard disk, then turn to TAG 002.

5 Is error message MC WRITE PROTECTED #572 displayed?

No: Go to #7 in this TAG.

Yes: Continue.

6 Turn the printer off and unplug the power cord.

- Disconnect J/P31 and J/P79.
- Check P31-28 to P79-28 for continuity to ground.

Is there continuity?

No: Replace the disk drive assembly and reload the printer's software onto the hard disk. If this resolves the problem, turn to TAG 002. If this does not resolve the problem, replace the RIGS board, then turn to TAG 002.

Yes: Replace the wire harness from the drive assembly to the RIGS board, W46, then turn to TAG 002.

7 Is error message MC FLOPPY NOT READY #573 displayed?

No: Go to #13 in this TAG.

Yes: Continue.

8 Turn the printer on.

- Check J/P8-1 for +5 Vdc.

Is the voltage +5 Vdc?

No: Replace the DC power supply, then turn to TAG 002.

Yes: Continue.

9 Check J/P77-4 for +5 Vdc.

Is the voltage +5 Vdc?

No: Repair or replace the connectors or wiring from P8-1 to P77-4, then turn to TAG 002.

Yes: Continue.

10 Check J/P8-3 for +12 Vdc.

Is the voltage +12 Vdc?

No: Replace the DC power supply, then turn to TAG 002.

Yes: Continue.

11 Check J/P77-1 for +12 Vdc.

Is the voltage +12 Vdc?

No: Repair or replace the connectors or wiring from P8-3 to P77-1, then turn to TAG 002.

Yes: Continue.

12 Turn the printer off and unplug the power cord.

- Disconnect J/P31 and J/P79.
- Check for continuity to ground:
P31-34 to P79-34,
P31-32 to P79-32,
P31-16 to P79-16, and
P31-10 to P79-10.

Is there continuity on any?

No: Replace the disk drive assembly and reload the printer's software onto the hard disk. If this does not resolve the problem, replace the RIGS board, then turn to TAG 002.

Yes: Replace the wire harness from the drive assembly to the RIGS board, W46, then turn to TAG 002.

13 **Is error message MC FDC RESTORE #574 displayed?**

No: Go to #16 in this TAG.

Yes: Continue.

14 Turn the printer off and unplug the power cord.

- Disconnect J/P31 and J/P79.
- Check P31-30 to P79-30 for continuity.

Is there continuity?

No: Replace the wire harness from the drive assembly to the RIGS board, W46, then turn to TAG 002.

Yes: Continue.

15 Check for continuity to ground:

- P31-18 to P79-18,
- P31-24 to P79-24, and
- P31-26 to P79-26.

Is there continuity on any?

No: Replace the disk drive assembly and reload the printer's software onto the hard disk. If this resolves the problem, turn to TAG 002. If this does not resolve the problem, replace the RIGS board, then turn to TAG 002.

Yes: Replace the wire harness from the drive assembly to the RIGS board, W46, then turn to TAG 002.

16 **Is error message MC FDC SEEK #575 displayed?**

No: Go to #18 in this TAG.

Yes: Continue.

-
- 17** Turn the printer off and unplug the power cord.
- Disconnect J/P31 and J/P79.
 - Check P31-20 to P79-20 and P31-18 to P79-18 for continuity.
- Is there continuity on each?**
- No:** Replace the wire harness from the drive assembly to the RIGS board, W46, then turn to TAG 002.
- Yes:** Replace the disk drive assembly and reload the printer's software onto the hard disk. If this resolves the problem, turn to TAG 002. If this does not resolve the problem, replace the RIGS board, then turn to TAG 002.
-

18 Is error message MC FDC READ #576 displayed?

No: Go to #21 in this TAG.

Yes: Continue.

- 19** Turn the printer off and unplug the power cord.

- Disconnect J/P31 and J/P79.
- Check for continuity:
 - P31-22 to P79-22,
 - P31-24 to P79-24,
 - P31-26 to P79-26,
 - P31-28 to P79-28, and
 - P31-32 to P79-32.

Is there continuity on each?

No: Replace the wire harness from the drive assembly to the RIGS board, W46, then turn to TAG 002.

Yes: Continue.

- 20** Check for continuity to ground:
P31-20,
P31-22,
P31-26, and
P31-32.

Is there continuity to ground on any?

No: Replace the disk drive assembly, then turn to TAG 002.

Yes: Replace the wire harness from the drive assembly to the RIGS board, W46.

21 Is error message 130, 131, 133, or 134 displayed?

No: Continue.

Yes: Replace the VPCL board, then turn to TAG 002.

22 Can the printer run test prints?

No: Continue.

Yes: Replace the disk drive assembly and reload the printer's software onto the hard disk. If this resolves the problem, turn to TAG 002. If this does not resolve the problem, replace the RIGS board, then turn to TAG 002.

TAG 130: Disk Drive Malfunction

- 23** Turn the printer off and unplug the power cord.
- Disconnect J/P31 and J/P79.
 - Check P31-34 to P79-34 for continuity to ground.

Is there continuity?

No: Replace the disk drive assembly and reload the printer's software onto the hard disk. If this resolves the problem, turn to TAG 002. If this does not resolve the problem, replace the RIGS board, then turn to TAG 002.

Yes: Replace the wire harness from the drive assembly to the RIGS board, W46, then turn to TAG 002.

TAG 200: RIGS Internal Communication Malfunction

ERROR MESSAGE:MC PERIPHERAL BUS #401
 MC FATAL SOFTWARE TRAP #454
 MC SOFTWARE TRAP #455
 MC PIT0 INVALID #500 TO MC PIT2 NO TIMER INTR #509
 MC NO DMAC RESET #520 TO MC NO DMAC2 TRANSFER #530 #540
 TO MC VSYNC TIMEOUT #566
 MC FDC/SCSI READ/WRITE #570
 MC FDC BUSY TIMEOUT #571
 MC FDC CHECKSUM #577 TO MC FDC/DMAC WRITE #585 #600-#610

Symptoms: *RIGS board failure*

Possible Causes: *RIGS program error*

Possible Defects (not listed in any particular order):

Wiring or connectors
RIGS board
Software
I/O card

- 1** Turn the printer off and unplug the power cord.
- Verify that J/P31, J/P32, J/P33, J/P79, and J/P74 are connected properly.
 - Power-on-reset the printer.

Has the problem been resolved?

No: Continue.

Yes: A loose connector was at fault. Turn to TAG 002.

2 **Was an error message displayed?**

No: Refer to the mechanical malfunctions cross-reference chart in [Section 2, TAG Cross-Reference Tables](#).

Yes: Continue.

3 **If the operator panel displayed more than one error message, was it the first message that displayed on the panel that led you to this TAG?**

No: Look in [Section 2, TAG Cross-Reference Tables](#)'s error message cross-reference chart under the first error message that displayed, then turn to the TAG referenced in the chart.

Yes: Continue.

4 Turn the printer off.

- Disconnect J/P31 and J/P79.
- Check P31-34 for continuity to ground.

Is there continuity to ground?

No: Continue.

Yes: Replace wire harness W46, then turn to TAG 002.

TAG 200: RIGS Internal Communication Malfunction

5 Replace the RIGS board, making sure that RIGS EPROM version is correctly matched to the software release installed on the printer.

- Power-on-reset the printer.

Has the problem been resolved?

No: Reinstall the original RIGS board and continue.

Yes: Turn to TAG 002.

6 Reinstall the printer's software. Follow the instructions for loading software in the *C40D Installation Guide*.

- Power-on-reset the printer.

Has the problem been resolved?

No: Replace the I/O card, then turn to TAG 002.

Yes: Software was at fault. Turn to TAG 002.

TAG 201: RIGS-VPCL Interface Malfunction

ERROR MESSAGE:121-127, 199-215

MC PCL CMD RETRY #380 TO MC PCL PARITY #387

Symptoms: *Communication failure between the RIGS board and the VPCL board*

Possible Causes: *Insufficient delay period between power off and power on
Electrical spikes*

Possible Defects (not listed in any particular order):

Connectors or wiring

VPCL board

RIGS board

DC power supply

High voltage power supply

1 **Is error message 201 displayed?**

No: Go to #3 in this TAG.

Yes: Continue.

2 Turn the printer off and unplug the power cord.

- Verify that J/P33 is connected properly.
- Power-on-reset the printer.

Has the problem been resolved?

No: Confirm that the RIGS firmware is correct for the version of software being used; then replace the RIGS board. Turn to TAG 002.

Yes: Turn to TAG 002.

3 **Is error message 121 or 123 displayed?**

No: Go to #6 in this TAG.

Yes: Continue.

4 Turn the printer off and unplug the power cord.

- Confirm that J/P33 is connected properly.

Are the connectors or wiring damaged?

No: Continue.

Yes: Replace the VPCL board, then turn to TAG 002.

5 Replace the VPCL board.

- Power-on-reset the printer.

Has the problem been resolved?

No: Continue.

Yes: Turn to TAG 002.

TAG 201: RIGS-VPCL Interface Malfunction

6

Replace the RIGS board.

- Power-on-reset the printer.

Has the problem been resolved?

No: If error message 121 or 123 brought you to this TAG, replace the DC or high voltage power supply, then turn to TAG 002. For all other error messages, replace the RIGS board, then turn to TAG 002.

Yes: Turn to TAG 002.

TAG 405: RIGS Bit-Map RAM Malfunction

ERROR MESSAGE:600-610

Possible Defects (not listed in any particular order):
RIGS board

-
- 1** The RIGS bit-map RAM has malfunctioned. Replace the RIGS board, then turn to TAG 002.
-

TAG 500: +5 Vdc Power Malfunction

Symptoms: *Operator panel blank with AC power supply cooling fan running*

Possible Defects (not listed in any particular order):

DC fuse
DC power supply
Connectors or wiring
Operator panel circuit board
VPCL board
RIGS board
Disk drive assembly
LED printhead assembly
Attachment option
AC power supply
Signal interface board
Duplex control board #1
Duplex control board #2

-
- 1** Turn off the printer and unplug the power cord.
- Confirm that J/P94, J/P4, J/P41, J/P91, J/P90, J/P6, and J/P8 are connected properly.
 - Power-on-reset the printer.

Is the operator panel still blank?

No: Loose connectors were at fault. Turn to TAG 002.

Yes: Continue.

- 2** Check J/P8-10 for +5 Vdc.

Is the voltage +5 Vdc?

No: Go to [#7](#) in this TAG.

Yes: Continue.

- 3** Check J/P91-5 for +5 Vdc.

Is the voltage +5 Vdc?

No: Repair or replace the connectors or wiring from P8-10 to P91-5, then turn to TAG 002.

Yes: Continue.

- 4** Check J/P94-1 for +5 Vdc.

Is the voltage +5 Vdc?

No: Repair or replace the connectors or wiring from P8-14 to J94-1, then turn to TAG 002.

Yes: Continue.

- 5** Check J/P42-1 for +5 Vdc.

Is the voltage +5 Vdc?

No: Repair or replace the connectors or wiring from P94-1 to J/P90-1 to P42-1, then turn to TAG 002.

Yes: Continue.

-
- 6** Turn the printer off and unplug the power cord.
- Disconnect J/P8 and J/P42.
 - Check P42-20 to P8-15 for continuity.
- Is there continuity?**
- No:** Repair or replace the connectors or wiring from P42-20 to J/P90-20 to J/P94-2 to P8-15, then turn to TAG 002.
- Yes:** Replace the operator panel circuit board. If this resolves the problem, turn to TAG 002. If this does not resolve the problem, replace the VPCL board, wire harness W72, or wire harness W63, then turn to TAG 002.
-

- 7** Turn the printer off.
- Disconnect J/P330.
 - Turn the printer on.
 - Check J/P8-1 for +5 Vdc.
- Is the voltage +5 Vdc?**
- No:** Continue.
- Yes:** Go to #16 in this TAG.
-

- 8** Turn the printer off.
- Disconnect J/P8.
 - Turn the printer on.
 - Check J/P330-3 for +5 Vdc.
- Is the voltage +5 Vdc?**
- No:** Go to #20 in this TAG.
- Yes:** Continue.
-

- 9** Turn the printer off.
- Reconnect J/P8.
 - Disconnect J/P77.
 - Turn the printer on.
 - Check J/P8-10 for +5 Vdc.
- Is the voltage +5 Vdc?**
- No:** Continue.
- Yes:** Replace the disk drive assembly, then turn to TAG 002.
-

- 10** Turn the printer off.
- Reconnect J/P77.
 - Disconnect J/P27.
 - Turn the printer on.
 - Check J/P8-10 for +5 Vdc.
- Is the voltage +5 Vdc?**
- No:** Continue.
- Yes:** Replace the LED printhead assembly, then turn to TAG 002.
-

- 11** Turn the printer off.
- Reconnect J/P27.
 - Disconnect J/P91.
 - Turn the printer on.
 - Check J/P8-10 for +5 Vdc.

Is the voltage +5 Vdc?

No: Continue.

Yes: Replace the VPCL board, then turn to TAG 002.

- 12** Turn the printer off.
- Reconnect J/P91.
 - Remove the IO card(s).
 - Turn the printer on.
 - Check J/P8-10 for +5 Vdc.

Is the voltage +5 Vdc?

No: Continue.

Yes: Replace the IO card(s), then turn to TAG 002.

- 13** Turn the printer off.
- Reinstall the IO card(s).
 - Disconnect J/P32.
 - Turn the printer on.
 - Check J/P8-10 for +5 Vdc.

Is the voltage +5 Vdc?

No: Continue.

Yes: Replace the RIGS board, then turn to TAG 002.

- 14** Turn the printer off.
- Reconnect J/P32.
 - Disconnect J/P94.
 - Turn the printer on.
 - Check J/P8-10 for +5 Vdc.

Is the voltage +5 Vdc?

No: Replace wire harness W36, then turn to TAG 002.

Yes: Continue.

- 15** Turn the printer off.
- Disconnect J/P42.
 - Check P42-1 for continuity to ground.

Is there continuity to ground?

No: Replace the operator panel circuit board, then turn to TAG 002.

Yes: Repair or replace the connectors or wiring from P94-1 to J/P90-1 to P42-1, then turn to TAG 002.

-
- 16** Turn the printer off.
- Reconnect J/P330.
 - Disconnect J/P331.
 - Turn the printer on.
 - Check J/P8-10 for +5 Vdc.

Is the voltage +5 Vdc?

No: Go to #18 in this TAG.

Yes: Continue.

- 17** Turn the printer off.
- Reconnect J/P331.
 - Disconnect J/P306.
 - Turn the printer on.
 - Check J/P8-10 for +5 Vdc.

Is the voltage +5 Vdc?

No: Repair or replace the connectors or wiring from J331-3 to P306-3, then turn to TAG 002.

Yes: Replace the duplex control board #1, then turn to TAG 002.

- 18** Turn the printer off.
- Reconnect J/P333.
 - Disconnect J/P323.
 - Turn the printer on.
 - Check J/P8-10 for +5 Vdc.

Is the voltage +5 Vdc?

No: Replace wire harness W127 or W128, then turn to TAG 002.

Yes: Continue.

- 19** Turn the printer off.
- Disconnect J/P310, found inside the duplex tray.
 - Check P310-3 for continuity to ground.

Is there continuity to ground?

No: Replace the duplex control board #2, then turn to TAG 002.

Yes: Repair or replace the connectors or wiring from J323-3 to J/P305-3 to P310-3, then turn to TAG 002.

- 20** Turn the printer on.
- ! Use extreme caution:**
- Check from J/P6-1 to J/P6-2 (neutral) for 100 Vac or more.

Is the voltage at least 100 Vac?

No: Continue.

Yes: Replace the DC power supply, then turn to TAG 002.

21 **! Use extreme caution:** Check from J/P4-7 to J/P4-8 (neutral) for 100 Vac or more.
Is the voltage at least 100 Vac?

No: Replace the AC power supply.

Yes: Repair or replace the connectors or wiring from:
P4-7 to P6-1 or
P4-8 to P6-2;
then turn to TAG 002.

TAG 600: Vac Power Malfunction

Symptoms: *Operator panel blank with fans not running*
 “Close cover” displayed
 Circuit breaker keeps tripping

Possible Defects (not listed in any particular order):
Upper fuse in the AC power supply
AC power supply
DC power supply
Connectors or wiring
Power control #2 board
Power control #3 board
Fuser
Back cover interlock switch
Front cover interlock switch
Top cover interlock switch
Toner supply motor
Cooling fans
Jogging motor
Main drive motor
Vacuum transport
Operator panel assembly

- 1** Turn the printer off and unplug the power cord.
- Verify that J/P44, J/P84, J/P4, J/P9, J/P12, J/P40, J/P6, and the AC power cord are connected properly.
 - Power-on-reset the printer.

Has the problem been resolved?

No: Continue.

Yes: Loose connectors were at fault. Turn to TAG 002.

- 2** Turn the printer off.
- Open the back cover and install an interlock by-pass tool.
 - Turn the printer on.
- ! Use extreme caution:** Check from J/P9-2 to J/P9-1 for +100 Vac.

Is the voltage +100 Vac?

No: Go to #4 in this TAG.

Yes: Continue.

- 3** Turn the printer off and unplug the power cord.
- Disconnect J/P40 and J/P12.
 - Check P40-29 to P12-3 and P40-30 to P12-4 for continuity.

Is there continuity on each?

No: Repair or replace the connectors or wiring as needed.

Yes: Replace the power control #2 board. If this resolves the problem, turn to TAG 002. If this does not resolve the problem, replace the VPCL board, then turn to TAG 002.

4 Does the CLOSE COVER message display on with all the covers closed?

No: Go to #24 in this TAG.

Yes: Continue.

5 Operate the top and front cover interlock switch actuators.

Are the interlock switch actuators working properly?

No: Repair or replace any defective actuator, then turn to TAG 002.

Yes: Continue.

6 ! Use extreme caution: Check from J/P4-4 to J/P4-3 for +100 Vac.
Is the voltage +100 Vac?

No: Continue.

Yes: Repair or replace the connectors or wiring from:

P9-2 to P4-4 or

P9-1 to P4-3.

If this is a duplex printer and the problem remains, go to TAG 900. If this corrects the problem, turn to TAG 002.

7 Turn the printer off and unplug the power cord.

- Remove the upper fuse in the AC power supply.

- Check the fuse for continuity.

Does the fuse have continuity?

No: Continue.

Yes: Go to #10 in this TAG.

8 Replace the upper fuse in the AC power supply.

- Reconnect the power.

- Power-on-reset the printer.

Was the power-on-reset successful?

No: Go to #14 in this TAG.

Yes: Continue.

9 Remove the developer.

- Run diagnostic test “Transfer Corona Test” on page 5-9 for approximately 5 seconds, then stop.

- Turn the printer off and unplug the power cord.

- Remove the fuse.

- Check the fuse for continuity.

Does the fuse have continuity?

No: Go to #12 in this TAG.

Yes: A defective fuse was at fault. Turn to TAG 002.

-
- 10** Reinstall the fuse.
- Disconnect J/P4.
 - Close the top cover.
 - Check P4-5 to P4-6 for continuity.

Is there continuity?

No: Go to [#33](#) in this TAG.

Yes: Continue.

- 11** Remove the AC power supply.
- Operate the front cover interlock switch.
 - Check for continuity as you operate the front interlock switch.

Does the front cover interlock switch have continuity?

No: Repair or replace the front interlock switch, then turn to TAG 002.

Yes: Repair or replace the AC power supply, then turn to TAG 002.

- 12** Disconnect J/P13.
- Install a new upper fuse in the AC power supply.
 - Run diagnostic test “[Transfer Corona Test](#)” on page 5-9 for approximately 5 seconds, then stop.
 - Remove the fuse.
 - Check the fuse for continuity.

Does the fuse have continuity?

No: Replace the power control #2 board, then turn to TAG 002.

Yes: Continue.

- 13** Disconnect J/P18.
- Check P13-5 to P18-1 for continuity to ground.

Is there continuity to ground?

No: Replace the toner supply motor, then turn to TAG 002.

Yes: Repair or replace the connectors or wiring from P18-1 to P13-5, then turn to TAG 002.

- 14** Turn off the printer.
- Disconnect J/P9.
 - Install a new upper fuse in the AC power supply.
 - Turn the printer on for 5 seconds, then off.
 - Remove the upper fuse.
 - Check the fuse for continuity.

Does the fuse have continuity?

No: Go to [#20](#) in this TAG.

Yes: Continue.

- 15** Reconnect J/P9.
- Install a good upper fuse in the AC power supply.
 - Disconnect J/P13 and J/P14.
 - Turn the printer on for 5 seconds, then off.
 - Remove the fuse.
 - Check the fuse for continuity.

Does the fuse have continuity?

No: Replace the power control #2 board, then turn to TAG 002.

Yes: Continue.

- 16** Reconnect J/P13 and J/P14.
- Disconnect J/P20, J/P21, J/P22, and J/P326 (duplex printers).
 - Power-on-reset the printer.
 - Wait 2¹/₂ minutes, then turn the printer off.
 - Remove the upper fuse in the AC power supply.
 - Check the fuse for continuity.

Does the fuse have continuity?

No: Repair or replace connectors or wiring that have continuity to ground:

P21-1 to P13-4,
P22-1 to P13-6,
J326-1 to P13-4, or
P20-2 to P14-6;
then turn to TAG 002.

Yes: Continue.

- 17** Turn the printer off.
- Reconnect J/P21.
 - Turn the printer on for 5 seconds, then off.
 - Remove the upper fuse in the AC power supply.
 - Check the fuse for continuity.

Does the fuse have continuity?

No: Replace the large cooling fan assembly, then turn to TAG 002.

Yes: Continue.

- 18** Turn the printer off.
- Reconnect J/P20.
 - Turn the printer on for 2-1/2 minutes, then off.
 - Remove the upper fuse from the AC power supply.
 - Check the fuse for continuity.

Does the fuse have continuity?

No: Replace the main drive motor and power supply, then turn to TAG 002.

Yes: Continue.

-
- 19** Turn the printer off.
- Reconnect J/P22.
 - Turn on the printer for 2¹/₂ minutes, then off.
- Was the power-on-reset successful?**
- No:** Replace the vacuum transport, then turn to TAG 002.
- Yes:** Replace the small cooling fan assembly, then turn to TAG 002.

-
- 20** Reconnect J/P9.
- Disconnect J/P100.
 - Install a new upper fuse in the AC power supply.
 - Run diagnostic test “[Photoconductor Seam Sensor Test](#)” on page 5-8 for approximately five seconds, then turn off the printer.
 - Remove the fuse.
 - Check the fuse for continuity.
- Does the fuse have continuity?**
- No:** Go to [#22](#) in this TAG.
- Yes:** Continue.

-
- 21** Turn off the printer.
- Reconnect J/P100.
 - Install a good upper fuse in the AC power supply.
 - Disconnect J/P101.
 - Run diagnostic test “[Photoconductor Seam Sensor Test](#)” on page 5-8 for approximately five seconds, then stop.
 - Remove the fuse.
 - Check the fuse for continuity.
- Does the fuse have continuity?**
- No:** Replace the power control #3 board, then turn to TAG 002.
- Yes:** Continue.

-
- 22** Disconnect J/P4 and J/P9.
- Check P4-4 to P9-2 and P4-4 to P100-1 for continuity to ground.
- Is there continuity to ground?**
- No:** Continue.
- Yes:** Repair or replace the connectors or wiring from P4-4 to P9-2 or P4-4 to P100-1; then turn to TAG 002.

- 23** Close the top cover.
- Check P4-5 for continuity to ground.
- Is there continuity?**
- No:** Replace the AC power supply, then turn to TAG 002.
- Yes:** Repair or replace the top cover interlock switch assembly. If this resolves the problem, turn to TAG 002. If this does not resolve the problem, repair or replace the connectors or wiring from:
P4-5 to J/P84-1 to P131, or
P132 to J/P84-2 to P4-6;
then turn to TAG 002.
-

- 24** **Is the operator panel blank and are the cooling and AC power supply fans off?**
- No:** You have chosen an incorrect TAG. Refer to the mechanical malfunctions cross-reference chart in [Section 2, TAG Cross-Reference Tables](#) to identify a more appropriate TAG.
- Yes:** Continue.
-

- 25** Turn off the printer and unplug the power cord.
- Check the wall power outlet for proper voltage.
- Is the voltage correct? If the circuit breaker was reset after beginning this TAG, answer no.**
- No:** Go to [#27](#) in this TAG.
- Yes:** Continue.
-

- 26** Unplug power cord from the printer and the wall outlet.
- Check the power cord for continuity.
- Is there continuity?**
- No:** Replace the power cord, then turn to TAG 002.
- Yes:** Replace the AC power supply, then turn to TAG 002.
-

- 27** Disconnect J/P4.
- Check P4-1 for continuity to ground.
- Is there continuity?**
- No:** Go to [#29](#) in this TAG.
- Yes:** Continue.
-

- 28** Remove the fuser.
- Check P4-1 to J/P44-3 to J5-1 to the fuser for continuity to ground.
- Is there continuity?**
- No:** Replace the fuser, making sure the fuser has the proper voltage rating, then turn to TAG 002.
- Yes:** Repair or replace connectors or wiring that have continuity, then turn to TAG 002.
-

- 29** Check J4-1 at the AC power supply for continuity to ground.
- Is there continuity?**
- No:** Continue.
- Yes:** Replace the AC power supply, then turn to TAG 002.
-

-
- 30** Check P4-7 for continuity to ground.
Is there continuity?
No: Go to [#32](#) in this TAG.
Yes: Continue.
-
- 31** Disconnect J/P6.
• Check P4-7 to P6-1 for continuity to ground.
Is there continuity?
No: Replace the DC power supply, then turn to TAG 002.
Yes: Repair or replace the connectors or wiring from P4-7 to P6-1, then turn to TAG 002.
-
- 32** Check J4-7 at the AC power supply for continuity to ground.
Is there continuity?
No: The customer's circuit breaker may be defective. Verify that the wall outlet has the proper voltage. If it does, continue; otherwise, turn to TAG 002.
Yes: Replace the AC power supply, then turn to TAG 002.
-
- 33** Disconnect J/P84.
• Check P4-5 to P84-1 and P4-6 to P84-2 for continuity.
Is there continuity on both?
No: Repair or replace the connectors or wiring that lack continuity, then turn to TAG 002.
Yes: Continue.
-
- 34** Check J84-1 to P131 and J84-2 to P132 for continuity.
Is there continuity on both?
No: Repair or replace the connectors or wiring that lack continuity, then turn to TAG 002.
Yes: Continue.
-
- 35** Check J131 to J132 (top interlock switch) for continuity while activating the top cover interlock switch.
Is there continuity?
No: Repair or replace the top cover interlock switch, then turn to TAG 002.
Yes: You have failed to isolate the problem. Return to the beginning of this TAG.
-

TAG 610: Operator Panel Malfunction

Symptoms: *One or more message indicators will not light*
Incomplete numbers are displayed
Tone does not work properly
All status lights remain on
One or more function keys do not work

Possible Causes: *Operator panel*
Connectors or wiring
VPCL board

- 1** Turn the printer off and unplug the power cord.
- Turn the volume control (on operator panel inside front cover) up fully.
 - Verify that J/P90, J/P42, J/P8, J/P41, and J/P94 are connected properly.
 - Run diagnostic test “[Operator Panel Test](#)” on page 5-4.

Has the problem been resolved?

No: Continue.

Yes: Loose connectors were at fault. Turn to TAG 002.

- 2** **Do the status lights stay on continuously?**

No: Continue.

Yes: Replace the VPCL board, then turn to TAG 002.

- 3** Turn the printer off and unplug the power cord.

- Disconnect J/P42, J/P91, J/P8, and J/P32.
- Check P8-15 to P42-20 for continuity.

Is there continuity?

No: Repair or replace the connectors or wiring from P8-15 to J/P94-2 to J/P90-20 to P42-20, then turn to TAG 002.

Yes: Continue.

- 4** Reconnect J/P42, J/P91, J/P8, and J/P32.

- Power-on-reset the printer.
 - When the “ready” indicator lights, press each function key and listen for the tone.
- !** Test prints may be produced. Press **STOP** or turn the printer **OFF** to quit.

Did you hear the tone after pressing each function key?

No: Go to [#14](#) in this TAG.

Yes: Continue.

- 5** **Is one of the function keys not working properly?**

No: Go to [#16](#) in this TAG.

Yes: Continue.

-
- 6** Turn the printer off and unplug the power cord.
- Disconnect J/P42 and J/P41.
 - Check P42-18 to P41-3 for continuity.
- Is there continuity?**
- No:** Repair or replace the connectors or wiring from P42-18 to J/P90-18 to P41-3, then turn to TAG 002.
- Yes:** Continue.
-
- 7** Check P41-3 to P42-18 for continuity to ground.
- Is there continuity?**
- No:** Continue.
- Yes:** Repair or replace the connectors or wiring from P42-18 to J/P90-18 to P41-3, then turn to TAG 002.
-
- 8** Check P42-17 to P41-4 for continuity.
- Is there continuity?**
- No:** Repair or replace the connectors or wiring from P42-17 to J/P90-17 to P41-4, then turn to TAG 002.
- Yes:** Continue.
-
- 9** Check P41-4 to P42-17 for continuity to ground.
- Is there continuity?**
- No:** Continue.
- Yes:** Repair or replace the connectors or wiring from P42-17 to J/P90-17 to P41-4, then turn to TAG 002.
-
- 10** Check P42-16 to P41-5 for continuity.
- Is there continuity?**
- No:** Repair or replace the connectors or wiring from P42-16 to J/P90-16 to P41-5, then turn to TAG 002.
- Yes:** Continue.
-
- 11** Check P41-5 to P42-16 for continuity to ground.
- Is there continuity?**
- No:** Continue.
- Yes:** Repair or replace the connectors or wiring from P42-16 to J/P90-16 to P41-5, then turn to TAG 002.
-
- 12** Check P42-15 to P41-6 for continuity.
- Is there continuity?**
- No:** Repair or replace the connectors or wiring from P42-15 to J/P90-15 to P41-6, then turn to TAG 002.
- Yes:** Continue.
-

TAG 610: Operator Panel Malfunction

- 13** Check P41-6 to P42-15 for continuity to ground.
Is there continuity?
- No:** Replace the operator panel. If this resolves the problem, turn to TAG 002. If this does not resolve the problem, replace the VPCL board, then turn to TAG 002.
- Yes:** Repair or replace the connectors or wiring from P42-15 to J/P90-15 to P41-6, then turn to TAG 002.
-

- 14** Turn the printer off and unplug the power cord.
- Disconnect J/P41 and J/P42.
 - Check P41-18 to P42-3 for continuity to ground.
- Is there continuity?**
- No:** Continue.
- Yes:** Repair or replace the connectors or wiring from P41-18 to J/P90-3 to P42-3, then turn to TAG 002.
-

- 15** Check P41-18 to P42-3 for continuity.
Is there continuity?
- No:** Repair or replace the connectors or wiring from P41-18 to J/P90-3 to P42-3, then turn to TAG 002.
- Yes:** Replace the operator panel. If this resolves the problem, turn to TAG 002. If this does not resolve the problem, replace the VPCL board, then turn to TAG 002.
-

- 16** Run diagnostic test [“Operator Panel Test” on page 5-4](#).
Does the combination of lights and display match the description in the diagnostic test?
- No:** Replace the operator panel.
- Does this resolve the problem?**
- No:** Replace the operator panel and continue.
- Yes:** Turn to TAG 002.
-

- 17** The problem is the wiring between the VPCL and operator panel. Repair or replace W63 and/or W72, then turn to TAG 002.
-

TAG 700: Output Tray Circuit Malfunction

Symptoms: *Invalid REMOVE PRINTS message on display*

Possible Defects (not listed in any particular order):

Output tray full sensor

Connectors or wiring

Job offset assembly

VPCL board

High capacity output unit

- 1** Turn the printer off and unplug the power cord.
- Verify that J/P50 and J/P40 are connected properly.
 - Power-on-reset the printer.

Has the problem been resolved?

No: Continue.

Yes: Loose connectors were at fault. Turn to TAG 002.

- 2** **Is a high capacity output unit installed on the printer?**

No: Go to [#4](#) in this TAG.

Yes: Continue.

- 3** Turn off the printer.
- Remove the high capacity output unit.
 - Turn on the printer.

Has the problem been resolved?

No: Continue.

Yes: The high capacity output unit is malfunctioning. Refer to [Section 8, Options](#), for instructions on repairing the high capacity unit.

- 4** Inspect the output tray full sensor actuator for damage or binding.

Is it in good working order?

No: Replace the actuator, then turn to TAG 002.

Yes: Continue.

- 5** Turn the printer off and unplug the power cord.

- Disconnect J/P51 and J/P40.
- Check P40-26 to P51-1 for continuity.

Is there continuity?

No: Repair or replace the connectors or wiring from P40-26 to J/P50-4 to P51-1, then turn to TAG 002.

Yes: Continue.

TAG 700: Output Tray Circuit Malfunction

6

Check P40-17 to P51-2 for continuity.

Is there continuity?

No: Repair or replace the connectors or wiring from P40-17 to J/P50-5 to P51-2, then turn to TAG 002.

Yes: Continue.

7

Check P40-13 to P51-3 for continuity.

Is there continuity?

No: Repair or replace the connectors or wiring from P40-13 to J/P50-6 to P51-3, then turn to TAG 002.

Yes: Continue.

8

Verify that the output tray full sensor is mounted properly.

- Verify that it moves down fully.

Is the output tray full sensor in good working order?

No: Replace the sensor, then turn to TAG 002.

Yes: Replace the VPCL board. If this resolves the problem, then turn to TAG 002. If this does not resolve the problem, replace wire harness W71 or W52, then turn to TAG 002.

TAG 702: Paper Size Detection Malfunction

Symptoms: *Incorrect paper size displayed*

Possible Defects (not listed in any particular order):

Upper cassette
Lower cassette
Upper paper size sensor
Lower paper size sensor
Connectors or wiring
VPCL board

- 1** Turn the printer off and unplug the power cord.
- Verify that J/P52 and J/P40 are connected properly.
 - Remove the upper and lower cassettes.
 - Make sure that the rear and side paper guides are securely against the paper.
 - Power-on-reset the printer.
 - Insert the cassette exhibiting the problem.

Does the display still indicate the incorrect paper size?

No: A loose connector or incorrectly positioned paper guides were at fault. Turn to TAG 002.

Yes: Continue.

- 2** Remove the cassette exhibiting the problem.
- Take out the paper.
 - Inspect the two paper size sensing balls on the bottom of the cassette by changing positions of the side and rear paper guides.

Is the paper size sensing mechanism in good working order?

No: Replace the defective cassette, then turn to TAG 002.

Yes: Continue.

- 3** Inspect the upper and lower paper size sensor assemblies.
- Is either paper size sensor assembly damaged or improperly mounted?**

No: Continue.

Yes: Remount, repair or replace the faulty paper size sensor assembly, then turn to TAG 002.

- 4** Remove the upper paper size sensor assembly.
- Disconnect the upper circuit board from its mounting.
 - Inspect the paper size sensor circuit board and mounting for damage or contamination.

Is the circuit board or mounting damaged or contaminated?

No: Continue.

Yes: Repair or replace the upper paper size sensor assembly, then turn to TAG 002.

TAG 702: Paper Size Detection Malfunction

- 5** Remove the lower paper size sensor assembly.
- Disconnect the circuit board from its mounting.
 - Inspect the paper size sensor circuit board and mounting for contamination or damage.
- Is the circuit board or mounting contaminated or damaged?**

No: Continue.

Yes: Repair or replace the lower paper size sensor assembly, then turn to TAG 002.

- 6** **Is the paper size sensing problem occurring with the upper cassette?**

No: Go to #8 in this TAG.

Yes: Continue.

- 7** Turn the printer off and unplug the power cord.
- Disconnect J/P40 and J/P45.
 - Refer to the charts at the end of this TAG.
 - Check the connectors or wiring for the upper paper size sensor.
- Is there a wiring problem?**

No: Replace the upper paper size sensor assembly. If this resolves the problem, turn to TAG 002. If this does not resolve the problem, replace the VPCL board, then turn to TAG 002.

Yes: Repair or replace the connectors or wiring that are defective, then turn to TAG 002.

- 8** Turn the printer off and unplug the power cord.
- Disconnect J/P40 and J/P43.
 - Refer to the chart at the end of this TAG.
 - Check the connectors or wiring for the lower paper size sensor.
- Is there a wiring problem?**

No: Replace the lower paper sensor assembly. If this resolves the problem, turn to TAG 002. If this does not resolve the problem, replace the VPCL board, then turn to TAG 002.

Yes: Repair or replace the connectors or wiring that are defective, then turn to TAG 002.

Wiring for the Upper Paper Size Sensor

Refer to the chart when performing continuity checks for an open or short to ground for the upper paper size sensor.

| Wiring Upper Paper Size Sensor | | | | |
|---------------------------------------|-------------|----------|-----------|-----------|
| P40-41 | to J/P52-10 | to J43-1 | to J47-10 | to J45-10 |
| P40-42 | to J/P52-9 | to J43-2 | to J47-9 | to J45-9 |
| P40-43 | to J/P52-8 | to J43-3 | to J47-8 | to J45-8 |
| P40-44 | to J/P52-7 | to J43-4 | to J47-7 | to J45-7 |
| P40-45 | to J/P52-6 | to J43-5 | to J47-6 | to J45-6 |
| P40-46 | to J/P52-5 | to J43-6 | to J47-5 | to J45-5 |
| P40-47 | to J/P52-4 | to J43-7 | to J47-4 | to J45-4 |
| P40-48 | to J/P52-3 | to J43-8 | to J47-3 | to J45-3 |
| P40-49 | to J/P52-2 | to J43-9 | to J47-2 | to J45-2 |

Wiring for the Lower Paper Size Sensor

Refer to the chart when performing continuity checks for an open or short to ground for the lower paper size sensor.

| Wiring Lower Paper Size Sensor | | |
|---------------------------------------|-------------|-----------|
| P40-41 | to J/P52-10 | to J43-1 |
| P40-42 | to J/P52-9 | to J43-2 |
| P40-43 | to J/P52-8 | to J43-3 |
| P40-44 | to J/P52-7 | to J43-4 |
| P40-45 | to J/P52-6 | to J43-5 |
| P40-46 | to J/P52-5 | to J43-6 |
| P40-47 | to J/P52-4 | to J43-7 |
| P40-49 | to J/P52-2 | to J43-9 |
| P40-50 | to J/P52-1 | to J43-10 |

TAG 703: Upper Cassette Malfunction

Symptoms: *Upper cassette does not load or unload properly*
 Upper cassette does not latch properly

Possible Defects (not listed in any particular order):

Upper cassette
Upper pressure lever
Upper cassette release latch
Upper cassette release
Damper assembly
Upper cassette release cam
Wire cable/roller/spring

1 Inspect the upper cassette for damage.
Is the upper cassette in good working order?
No: Replace the upper cassette, then turn to TAG 002.
Yes: Continue.

2 Inspect the following for damage:

- Upper pressure lever
- Upper cassette release latch
- Upper cassette release
- Damper assembly
- Upper cassette release cam
- Wire cable/roller/spring

Are all parts in good working order?
No: Repair or replace the damaged part, then turn to TAG 002.
Yes: Only mechanical defects and malfunctions can cause this type of problem. Carefully reinspect each part. Repair or replace and defective parts, then turn to TAG 002.

TAG 704: Lower Cassette Malfunction

Symptoms: *Lower cassette does not load or unload properly*
 Lower cassette does not latch properly

Possible Defects (not listed in any particular order):
Lower cassette
Lower pressure lever
Lower cassette release latch
Lower cassette release
Lower cassette release cam
Spring

1 Inspect the lower cassette for damage.
Is the lower cassette in good working order?
No: Replace the lower cassette, then turn to TAG 002.
Yes: Continue.

2 Inspect the following for damage:

- Lower pressure lever
- Lower cassette release latch
- Lower cassette release
- Lower cassette release cam
- Spring

Are all the parts in good working order?
No: Repair or replace the damaged part, then turn to TAG 002.
Yes: Only mechanical defects and malfunctions can cause this type of problem. Carefully reinspect each part. Repair or replace the damaged part, then turn to TAG 002.

TAG 705: Multiple Paper Feeding

Possible Causes: *Wrong weight or type of paper loaded*
Paper improperly loaded

Possible Defects (not listed in any particular order):
Upper feed roller assembly
Lower feed roller assembly
Paper cassette

- 1** Remove paper from the cassette.
- Fan the paper stack and place it in the cassette.
 - Make sure the paper curl is turned up in the cassette.
 - Make sure the paper is under the corner separators.
 - Make sure the rear and side paper guides are positioned properly.
 - Make sure the paper being used does not have a high static charge.
 - Confirm that the paper in the cassettes meets paper specifications.
 - Run at least 20 test prints.

Has the problem been resolved?

No: Continue.

Yes: The paper being used was at fault. Turn to TAG 002.

- 2** Adjust the paper tension lever or pick pressure as outlined in [Section 9, General Printer Maintenance](#).

Has the problem been resolved?

No: Replace the pick-up roller assembly, then turn to TAG 002.

Yes: Turn to TAG 002.

TAG 706: Paper Damaged or Wrinkled

Possible Causes: *Paper incorrectly loaded*
Wrong weight or type of paper loaded
Paper path obstructed

Possible Defects (not listed in any particular order):
Fuser
Exit roller assembly
Exit pinch roller assembly

- 1** Make sure the paper being used is not damaged.
- Make sure the paper is loaded properly.
 - Make sure the side and rear paper guides in the paper cassettes are positioned properly.
 - Check both upper and lower paper paths for obstructions or roller contamination.
 - Confirm that the paper in the cassettes meets paper specifications.
 - Power-on-reset the printer.
 - Run test prints from the upper cassette.

Are the prints wrinkled or damaged?

No: Continue.

Yes: Go to [#3](#) in this TAG.

- 2** Remove the upper cassette.
- Power-on-reset the printer.
 - Run test prints from the lower cassette.

Are the prints wrinkled or damaged?

No: The paper in use was at fault. Turn to TAG 002.

Yes: Continue.

- 3** Run a test print from the cassette exhibiting the problem.

Is the print on the paper skewed?

No: Continue.

Yes: Go to TAG 807.

- 4** Remove the exit cover assembly.
- Inspect the exit roller assembly for damage, wear, or contamination.
 - Inspect the exit pinch roller for damage, wear, or contamination.

Is either part damaged, worn, or contaminated?

No: Replace the fuser, then turn to TAG 002.

Yes: Repair or replace the part as needed, then turn to TAG 002.

TAG 707: Upper Paper Guide Assembly Not Closing

Possible Causes: *Obstructions*

Photoconductor front or rear latch arm springs

Photoconductor latch arms in incorrect position

Upper paper guide latching mechanism damaged or binding

Front or rear photoconductor guides damaged

Possible Defects (not listed in any particular order):

Photoconductor latch arms

Upper paper guide latch

Photoconductor guide rails

1

Check under the upper paper guide assembly for obstructions.

- Remove the photoconductor from the printer.
- Inspect the front and rear photoconductor latch arm springs for damage.
- Inspect the front and rear photoconductor guide rails for damage.
- Make sure there are no obstructions in the mounting area of the photoconductor.
- Make sure the upper paper guide latching mechanism is functioning properly.
- Make sure the photoconductor latch arms are in the upper position.

Are all parts in good working order?

No: Repair or replace any malfunctioning parts, then turn to TAG 002.

Yes: Continue.

Yes: Remove the photoconductor.

- Close and lock the upper paper guide.

Did the upper paper guide lock into place?

No: Replace the upper paper guide, then turn to TAG 002.

Yes: Only mechanical defects and malfunctions can cause this type of problem. Go to #1 in this TAG and carefully reinspect each part.

TAG 750: Counter Malfunction

Symptoms: *Counter does not count*
 Counter counts too often
 Consumable components require replacement too frequently

Possible Defects (not listed in any particular order):
 Counter assembly
 Connectors or wiring
 VPCL board

-
- 1** Run diagnostic test “Counter Test” on page 5-7.
Is the counter functioning properly?
No: Continue.
Yes: The counter is working correctly. Turn to TAG 002.
-
- 2** Verify that J/P41, J/P81, and J/P82 are connected properly.
 • Run diagnostic test “Counter Test” on page 5-7.
Is the counter functioning properly?
No: Continue.
Yes: Loose connectors were at fault. Turn to TAG 002.
-
- 3** Replace the counter.
 • Run test prints.
Has the problem been resolved?
No: Replace the VPCL board, then turn to TAG 002.
Yes: The counter was at fault. Turn to TAG 002.
-
- 4** Replace the VPCL board.
Has the problem been resolved?
No: Replace the VPCL board and continue.
Yes: The VPCL board was at fault. Turn to TAG 002.
-
- 5** Turn the printer off and unplug the power cord.
 • Disconnect J/P41 and J/P82.
 • Check P41-26 to J82-1 for continuity.
Is there continuity?
No: Repair or replace the connectors or wiring from P41-26 to J/P81-1 to J82-1, then turn to TAG 002.
Yes: Continue.

TAG 750: Counter Malfunction

6 Check P41-25 to J82-2 for continuity.

Is there continuity?

No: Repair or replace the connectors or wiring from P41-25 to J/P81-2 to J82-2, then turn to TAG 002.

Yes: Replace the counter. If this resolves the problem, turn to TAG 002. If this does not resolve the problem, replace the VPCL board, then turn to TAG 002.

TAG 751: Main Drive Motor Runs Continuously

Possible Defects (not listed in any particular order):

Power control #2 board

Connectors or wiring

VPCL board

1 Turn the printer off and unplug the power cord.

- Disconnect J/P12 and J/P40.
- Check P40-33 for continuity to ground.

Is there continuity?

No: Replace the power control #2 board. If this resolves the problem, turn to TAG 002. If this does not resolve the problem, replace the VPCL board, then turn to TAG 002.

Yes: Repair or replace the connectors or wiring from P40-33 to P12-7, then turn to TAG 002.

TAG 753: Async IO Communications Malfunction

ERROR MESSAGE:MC HOST SCC ERROR #701-#722

Symptoms: *Test prints can be made but jobs do not run
Jobs do not print correctly*

Possible Causes: *Improper DIP switch settings
Host computer
Improper application*

Possible Defects (not listed in any particular order):
*RIGS board communications cable
Cable connectors
I/O card
Diskette
Wrap connector
DC power supply*

! Communication problems may require trial replacement of numerous parts. After each trial replacement, run the job that exhibited the failure.

- 1** Turn the printer off and unplug the power cord.
- Verify that J/P8, J/P32, J/P74, and J/P92 are connected properly.
 - Verify that all communication cables are attached properly.
 - Verify that the correct software is installed in the printer.
 - Reseat the IO card(s).
 - Power-on-reset the printer.
 - Confirm that the printer's soft configuration is set properly.
 - Run the failing job.

Has the problem been resolved?

No: Continue.

Yes: Loose connectors or software configuration were at fault. Determine which of these is at fault, correct the problem, then turn to TAG 002.

- 2** Turn the printer off.
- Reload the software on the hard disk.
 - Power-on-reset the printer.
 - Confirm that the printer's software configuration is set correctly to the interface you are using.

Has the problem been resolved?

No: Continue.

Yes: Software or software configuration were at fault. Determine which of these is at fault, correct the problem, then turn to TAG 002.

-
- 3** Disconnect the interface cable from the printer.
- Install the RS-232C and RS-422 wrap connectors.
 - Run diagnostic test “[LED Printhead Test](#)” on page 5-15.
- Did the diagnostic test run properly?**
- No:** Continue.
- Yes:** Go to [#11](#) in this TAG.
-
- 4** Turn the printer off and unplug the power cord.
- Inspect J/P71 (RS-232C), J/P72 (RS-422), and J/P74 for connector body cracks or damaged pins.
- Is there a problem with the connectors or pins?**
- No:** Go to [#7](#) in this TAG.
- Yes:** Continue.
-
- 5** Replace the I/O card(s).
- Run diagnostic test “[LED Printhead Test](#)” on page 5-15.
- Did the diagnostic test run properly?**
- No:** Continue.
- Yes:** The I/O card was at fault. Turn to TAG 002.
-
- 6** Replace the RIGS board.
- Run diagnostic test “[LED Printhead Test](#)” on page 5-15.
- Did the diagnostic test run properly?**
- No:** Continue.
- Yes:** The RIGS board was at fault. Turn to TAG 002.
-
- 7** Open the back cover and install an interlock by-pass tool.
- Power-on-reset the printer.
 - Check J/P32-10 for +12 Vdc.
- Is the voltage +12 Vdc?**
- No:** Repair or replace the connectors or wiring from P8-6 to P32-10, then turn to TAG 002.
- Yes:** Continue.
-
- 8** Check J/P32-3 for -12 Vdc.
- Is the voltage -12 Vdc?**
- No:** Continue.
- Yes:** Replace the signal interface board, then turn to TAG 002. If this does not resolve the problem, replace the RIGS board, then turn to TAG 002.
-
- 9** Check J/P8-8 for -12 Vdc.
- Is the voltage -12 Vdc?**
- No:** Replace the DC power supply, then turn to TAG 002.
- Yes:** Repair or replace connectors or wiring from P8-8 to P32-3, then turn to TAG 002.

10 Does the problem appear while using RS-232C communications?

No: The problem may be caused by the RIGS board, I/O card, host computer, or host interface cable. Determine which of these are at fault, correct the problem, then turn to TAG 002.

Yes: Continue.

11 Turn the printer off and unplug the power cord.

- Install a breakout box on the printer to confirm that the host interface cable works as outlined in the chart that follows.
- Reconnect all communication lines.
- Reconnect any external attachment option.
- Power-on-reset the printer.
- Run the failing job again.

| Host Computer | | | Printer | | | Description |
|---------------|-------|------------|---------|--------|-----|---|
| Signal | Pin # | Directions | Pin # | Signal | | |
| FG | 1 | | | 1 | FG | |
| SG | 7 | | | 7 | SG | |
| TD | 2 | -> | <- | 2 | TD | Data OUT (status) |
| TD | 2 | <- | -> | 3 | RD | Data in (CMD/Data) |
| RTS | 4 | -> | <- | 4 | RTS | Optional; continuous positive voltage for host computers that require a "printer present" indication. |
| CTS | 5 | <- | | 5 | CTS | Must go to a positive voltage from the host computer. It is only looked at by the printer at power-on initialization. |
| DSR | 6 | <- | -> | | | |
| DCD | 8 | <- | | | | |
| DTR | 20 | -> | | 20 | DTR | Depends on printer soft configuration option 15. DTR will always be a positive voltage if set to "DTR High". DTR will change from a positive to a negative voltage if set to "DTR Pacing" and the buffer is full. |

Does your cable work as outlined in the Cable Reference Chart above?

No: The problem appears to be related to the host computer or host interface cable. Correct the problem, then turn to TAG 002.

Yes: The problem may be caused by the RIGS board, signal interface board, or outdated printer software. Determine which of these is at fault, correct the problem, then turn to TAG 002.

TAG 754: Smart I/O Card Malfunction

Symptoms: *Job fails only when a smart I/O card is used.*

Possible Causes: *Lack of voltage*

Possible Defects (not listed in any particular order):

*Attachment option
Communication cables
Cable connectors
Signal interface board
Signal interface board fuse
RIGS board
Host computer
Host interface cable*

! Communication problems may require trial replacement of numerous parts. After each trial replacement, run the job that exhibited failure.

-
- 1** Turn off the printer and unplug the power cord.
- Disconnect all attachment cables.
 - Open the back cover and install an interlock by-pass tool.
 - Confirm that J/P8, J/P32, and J/P74 are connected properly.
 - Reseat the IO card.
 - Reinstall all communication cables.
 - Power-on-reset the printer.
 - Confirm that the printer has been correctly configured using the printer's soft configuration mode.
 - Run the failing job.
- Has the problem been resolved?**
- No:** Continue.
- Yes:** Loose or damaged connectors or software configuration were at fault. Turn to TAG 002.

-
- 2** Turn on the printer.
- Check for the indicated voltages:
 - J73-1 should be +5 Vdc;
 - J73-3 should be +12 Vdc;
 - J73-4 should be -12 Vdc;
 - J73-6 should be +5 Vdc.
- Are all voltages correct?**
- No:** Replace the optional IO card. If this resolves the problem, turn to TAG 002. If this doesn't resolve the problem, go to the appropriate TAG for the incorrect voltage and continue.
- Yes:** Continue.

TAG 754: Smart I/O Card Malfunction

3 Turn off the printer and unplug the power cord.

- Replace the optional IO card.
- Reconnect all communication cables.
- Run the failing job.

Has the problem been resolved?

No: The problem appears to be related to the host computer or the host interface cable. Correct the problem, then turn to TAG 002.

Yes: The external attachment option was at fault. Turn to TAG 002.

TAG 800: Prints Blank or With Dark Horizontal Bands

Possible Defects (not listed in any particular order):

Photoconductor
Printhead assembly
RIGS board
Main drive gear assembly
Connectors or wiring
Transfer corona
High voltage power supply
Upper paper guide assembly
Developer

! If there is a developed image on the paper other than dark horizontal bands, follow TAG 804.

-
- 1** Turn the printer off and unplug the power cord.
- Verify that J/P7, J/P27, J/P41, J/P23, J/P30, J/P31, and transfer corona high voltage power supply lead are connected properly.
 - Refer to [Section 9, General Printer Maintenance](#), and perform the every-call cleaning procedure.
 - Run test prints.

Has the problem been resolved?

No: Continue.

Yes: Loose connectors or contamination were at fault. Turn to TAG 002.

-
- 2** Refer to [Section 9, General Printer Maintenance](#), and check the voltages.

Are the voltages correct?

No: Replace the high voltage power supply, then turn to TAG 002.

Yes: Continue.

-
- 3** **Have the photoconductor, charge corona, developer, and toner cartridge been replaced recently?**

No: Continue.

Yes: Go to [#6](#) in this TAG.

-
- 4** Replace the photoconductor and charge corona.

- Run test prints.

Has the problem been resolved?

No: Reinstall original photoconductor and charge corona and continue.

Yes: The photoconductor was at fault. Turn to TAG 002.

-
- 5** Replace the developer and toner cartridge.

- Run test prints.

Has the problem been resolved?

No: Reinstall the original developer and continue.

Yes: Turn to TAG 002. If the problem recurs, the toner carrier mix may be old or contaminated.

TAG 800: Prints Blank or With Dark Horizontal Bands

6 Produce a developed image on the photoconductor.

Is a developed image on the photoconductor?

No: Go to #10 in this TAG.

Yes: Continue.

7 Remove and clean the transfer corona.

- Clean the transfer corona contacts in the upper paper guide.
- Inspect the transfer corona contacts for proper alignment.
- Reinstall the transfer corona.
- Power-on-reset the printer.
- Run test prints.

Has the problem been resolved?

No: Continue.

Yes: Turn to TAG 002.

8 Turn the printer off and unplug the power cord.

- Remove the transfer corona.
- Check the lower transfer corona contact, with the upper paper guide assembly in its fully upright position, for continuity to ground.

Is there continuity?

No: Replace the upper paper guide assembly, then turn to TAG 002.

Yes: Continue.

9 Replace the transfer corona.

- Power-on-reset the printer.
- Run test prints.

Has the problem been resolved?

No: Replace the upper paper guide assembly. If this resolves the problem, turn to TAG 002. If this does not resolve the problem, replace the high voltage power supply, then turn to TAG 002.

Yes: The transfer corona was at fault. Turn to TAG 002.

10 Replace the printhead.

- Produce a developed image on the photoconductor.

Is a developed image on the photoconductor?

No: Go to #18 in this TAG.

Yes: Continue.

11 **Are the prints blank without dark bands?**

No: Go to #15 in this TAG.

Yes: Continue.

12 Remove the photoconductor and place it in its protective packaging.

- Remove the developer.
- Inspect the drive coupling on the developer for damage.

Is the coupling damaged?

No: Continue.

Yes: Replace the developer, then turn to TAG 002.

13 Rotate the drive coupling on the developer clockwise.

- Watch the magnetic brush.

Does the magnetic brush turn?

No: Replace the developer, then turn to TAG 002.

Yes: Continue.

14 Reinstall the photoconductor.

- Run diagnostic test [“Photoconductor Seam Sensor Test”](#) on page 5-8.
- Watch the developer drive coupling at the rear of the developer cavity.

Does the developer drive coupling turn?

No: Repair or replace the main drive gear assembly, then turn to TAG 002.

Yes: Replace the high voltage power supply, then turn to TAG 002.

15 **Do the prints have one or more horizontal dark bands?**

No: The problem has not been identified. Go back to TAG 001 and begin again.

Yes: Continue.

16 Turn the printer off and unplug the power cord.

- Remove the photoconductor.
- Clean the photoconductor contacts and guide rail contacts.
- Check the bottom connector contact on the photoconductor guide rail for continuity to ground.

Is there continuity?

No: Repair or replace the grounding circuit wiring, then turn to TAG 002.

Yes: Continue.

17 Reinstall the photoconductor.

- Turn the printer on.
- Run test prints.

Has the problem been resolved?

No: Replace the photoconductor, then turn to TAG 002.

Yes: Contamination was at fault. Turn to TAG 002.

TAG 800: Prints Blank or With Dark Horizontal Bands

18 Check J/P27-1, J/P27-2, and J/P27-3 for +5 Vdc.

Is there +5 Vdc at each?

No: Continue.

Yes: Replace wire harness W46. If this resolves the problem, turn to TAG 002. If this doesn't resolve the problem, replace the RIGS board, then turn to TAG 002.

19 Check J/P7-1 for +5 Vdc.

Is the voltage +5 Vdc?

No: Replace the DC power supply, then turn to TAG 002.

Yes: Replace wire harness W37, then turn to TAG 002.

TAG 801: Prints Light or Light With Carrier Particles

Possible Defects (not listed in any particular order):

Photoconductor
Connectors or wiring
Main drive gear assembly
Transfer corona
Power control #2 board
Printhead assembly
High voltage power supply
Toner supply motor
VPCL board
Upper paper guide assembly
Developer

! If the problem still exists after completing this TAG, go to TAG 800.

-
- 1** Run test prints.
- Examine the letters A, V, and W for jaggedness on the diagonal lines.
- Are they jagged?**
- No:** Continue.
- Yes:** Refer to [Section 4, Print Quality Samples](#). Review the printhead problem print samples, identify one similar to the test prints, and turn to the associated TAG.
-
- 2** Turn the printer off and unplug the power cord.
- Verify that J/P12, J/P13, J/P18, and J/P41 are connected properly.
 - Refer to [Section 9, General Printer Maintenance](#), and perform the every-call cleaning procedure.
 - Clean the printhead lens and toner patch sensor located on the developer.
 - Turn the printer on.
 - Run test prints.
- Has the problem been resolved?**
- No:** Continue.
- Yes:** Contamination or loose connectors were at fault. Turn to TAG 002.
-
- 3** Refer to [Section 9, General Printer Maintenance](#), and check the voltages.
- Are the voltages correct?**
- No:** Replace the high voltage power supply, then turn to TAG 002.
- Yes:** Continue.
-
- 4** **Have the photoconductor, charge corona, developer, and toner cartridge been replaced recently?**
- No:** Continue.
- Yes:** Go to [#7](#) in this TAG.

TAG 801: Prints Light or Light With Carrier Particles

- 5** Replace the photoconductor and charge corona.
- Run test prints.
- Has the problem been resolved?**
- No:** Reinstall the original photoconductor and charge corona and continue.
- Yes:** Run at least 200 test prints to detone the engine, then turn to TAG 002.
-

- 6** Replace the developer and toner cartridge.
- Run test prints.
- Has the problem been resolved?**
- No:** Reinstall the original developer and continue.
- Yes:** Turn to TAG 002.
-

- 7** Produce a developed image on the photoconductor.
- Is the developed image on the photoconductor correct?**
- No:** Go to #11 in this TAG.
- Yes:** Continue.
-

- 8** Remove and clean the transfer corona.
- Clean the transfer corona contacts in the upper paper guide.
 - Inspect the transfer corona contacts for proper alignment.
 - Reinstall the transfer corona.
 - Power-on-reset the printer.
 - Run test prints.
- Has the problem been resolved?**
- No:** Continue.
- Yes:** Turn to TAG 002.
-

- 9** Turn the printer off and unplug the power cord.
- Remove the transfer corona.
 - Check the lower transfer corona contact, with the upper paper guide assembly in its fully upright position, for continuity to ground.
- Is there continuity?**
- No:** Repair or replace the upper paper guide assembly, then turn to TAG 002.
- Yes:** Continue.
-

- 10** Turn the printer off and unplug the power cord.
- Replace the transfer corona.
 - Power-on-reset the printer.
 - Run test prints.
- Has the problem been resolved?**
- No:** Replace the upper paper guide assembly. If this resolves the problem, turn to TAG 002. If this does not resolve the problem, replace the high voltage power supply, then turn to TAG 002.
- Yes:** The transfer corona was at fault. Turn to TAG 002.

-
- 11** Open the front cover and install an interlock by-pass tool.
- Remove the photoconductor.
 - Remove the developer.
 - Run diagnostic test [“Toner Supply Motor Test” on page 5-8.](#)
 - Watch the toner motor coupling in the developer cavity.

Does the coupling turn?

No: Go to [#20](#) in this TAG.

Yes: Continue.

- 12** Inspect the toner drive coupling on the developer for damage.

Is the coupling damaged?

No: Continue.

Yes: Replace the developer, then turn to TAG 002.

- 13** Rotate both the drive couplings on the developer clockwise.

Do both drive couplings rotate freely?

No: Replace the developer, then turn to TAG 002.

Yes: Continue.

- 14** Reinstall the photoconductor.

- Run diagnostic test [“Photoconductor Seam Sensor Test” on page 5-8.](#)
- Watch the developer drive coupling in the developer cavity.

Does the coupling turn?

No: Repair or replace the main drive gear assembly, then turn to TAG 002.

Yes: Continue.

- 15** Turn the printer off and unplug the power cord.

- Disconnect J/P41, J/P24, and J/P23.
- Check the following for continuity:
 - P41-30 to J24-4,
 - P41-38 to J23-2,
 - P41-43 to J25-5,
 - P41-44 to J25-2,
 - P41-47 to J25-3,
 - P41-48 to J25-6,
 - P41-49 to J25-4, and
 - P41-50 to J25-1.

Is there continuity on all?

No: Repair or replace the connectors or wiring that do not have continuity, then turn to TAG 002.

Yes: Continue.

TAG 801: Prints Light or Light With Carrier Particles

- 16** Reconnect J/P23, J/P41, and J/P24.
- Reinstall the developer.
 - Power-on-reset the printer.
 - Refer to [Section 9, General Printer Maintenance](#), and check the voltages.

Are the voltages correct?

No: Replace the high voltage power supply, then turn to TAG 002.

Yes: Go to #17 in this TAG.

- 17** Turn the printer off and unplug the power cord.
- Replace the charge corona terminal assembly.
 - Power-on-reset the printer.
 - Run test prints.

Has the problem been resolved?

No: Reinstall the original charge corona terminal assembly and continue.

Yes: Turn to TAG 800.

- 18** Turn the printer off and unplug the power cord.
- Replace the printhead assembly.
 - Power-on-reset the printer.
 - Run test prints.

Has the problem been resolved?

No: Reinstall the original printhead assembly and continue.

Yes: Turn to TAG 002.

- 19** Turn the printer off and unplug the power cord.
- Replace the RIGS board.
 - Power-on-reset the printer.
 - Run test prints.

Has the problem been resolved?

No: Reinstall the original RIGS board and go to TAG 800.

- 20** Turn to TAG 002.
- Run diagnostic test [“Toner Supply Motor Test” on page 5-8](#).
- ! Use extreme caution:**
- Check J/P13-5 to J/P13-2 for 100 Vac while the test is running.

Is the voltage 100 Vac?

No: Replace the VPCL board. If this does not resolve the problem, repair or replace the wiring from J/P 13 to P40, then turn to TAG 002.

Yes: Continue.

21 Run diagnostic test “[Toner Supply Motor Test](#)” on page 5-8.

! Use extreme caution:

- Check J/P18-1 to J/P18-2 for 100 Vac while the test is running.

Is the voltage 100 Vac?

No: Repair or replace the connectors or wiring from P18-1 to P13-5, P18-2 to P13-2, or both.

Yes: Replace the toner supply motor, then turn to TAG 002.

TAG 802: Prints With Voids or White Spots

Possible Causes: *Wrong weight or type of paper loaded*

Possible Defects (not listed in any particular order):

Photoconductor

Developer

- 1** Perform the every-call cleaning procedure.
- Confirm that the paper in the cassettes meets paper specifications.
 - Turn the printer on.
 - Run test prints.

Has the problem been resolved?

No: Continue.

Yes: Contamination was at fault. Turn to TAG 002.

- 2** Refer to [Section 9, General Printer Maintenance](#), and check the voltages.

Are the voltages correct?

No: Replace the high voltage power supply, then turn to TAG 002.

Yes: Continue.

- 3** **Have the photoconductor, developer, and fuser been replaced recently?**

No: Continue.

Yes: Refer to [Section 4, Print Quality Samples](#). Compare the test prints with the print samples, and identify a sample having the same print flaw as the test prints; turn to the TAG listed under the sample.

- 4** Replace the photoconductor and charge corona.

- Run test prints.

Has the problem been resolved?

No: Reinstall the original photoconductor and charge corona, and continue.

Yes: Turn to TAG 002.

- 5** Replace the developer and toner cartridge.

- Run test prints.

Has the problem been resolved?

No: Reinstall the original developer and continue.

Yes: Turn to TAG 002.

6 Replace the fuser.

- Run test prints.

Has the problem been resolved?

No: Reinstall the original fuser. Refer to [Section 4, Print Quality Samples](#). Compare the test prints with the print samples, and identify a sample having the same print flaw as the test prints; turn to the TAG listed under the sample.

Yes: Turn to TAG 002.

TAG 803: Prints With Light or White Vertical Streaks

Possible Defects (not listed in any particular order):

Transfer corona
Printhead assembly
Photoconductor
Developer

-
- 1** Turn off the printer and unplug the power cord.
- Verify that J/P13, J/P30, and J/P31 are connected properly.
 - Make sure the customer's paper supply is not at fault.
 - Refer to [Section 9, General Printer Maintenance](#) and perform the every-call cleaning procedure.
 - Turn the printer on.
 - Run test prints.

Has the problem been resolved?

No: Continue.

Yes: Loose connectors or contamination were at fault. Turn to TAG 002.

-
- 2** Refer to [Section 9, General Printer Maintenance](#), and check the voltages.

Are the voltages correct?

No: Replace the high voltage power supply, then turn to TAG 002.

Yes: Continue.

-
- 3** **Have the photoconductor, charge corona, and developer been replaced recently?**

No: Continue.

Yes: Go to [#6](#) in this TAG.

-
- 4** Replace the photoconductor and charge corona.

- Run test prints.

Has the problem been resolved?

No: Reinstall the original photoconductor and charge corona, and continue.

Yes: Turn to TAG 002.

-
- 5** Replace the developer and toner cartridge.

- Run test prints.

Has the problem been resolved?

No: Reinstall the original developer and continue.

Yes: Turn to TAG 002.

-
- 6** Turn on the printer.

- Produce a developed image on the photoconductor.

Are there vertical streaks on the photoconductor belt image?

No: Replace the transfer corona, then turn to TAG 002.

Yes: Replace the printhead assembly, then turn to TAG 002.

TAG 804: Prints With Light Horizontal Bands

Possible Causes: *Loose printhead connectors*

Possible Defects (not listed in any particular order):

Transfer corona

Photoconductor

Charge corona

- 1** Turn the printer off and unplug the power cord.
- Refer to [Section 9, General Printer Maintenance](#), and perform the every-call cleaning procedure.
 - Verify that J/P30 and J/P31 are connected properly.
 - Turn the printer on.
 - Run test prints.

Has the problem been resolved?

No: Continue.

Yes: Contamination or loose connectors were at fault. Turn to TAG 002.

- 2** Refer to [Section 9, General Printer Maintenance](#), and check the voltages.

Are the voltages correct?

No: Replace the high voltage power supply, then turn to TAG 002.

Yes: Continue.

- 3** **Have the photoconductor and charge corona have been replaced recently?**

No: Continue.

Yes: Go to [#5](#) in this TAG.

- 4** Replace the photoconductor and charge corona.

- Turn on the printer.
- Run test prints.

Has the problem been resolved?

No: Reinstall the original photoconductor and charge corona, then continue.

Yes: Turn to TAG 002.

- 5** Replace the transfer corona.

Has the problem been resolved?

No: Replace the photoconductor. If this resolves the problem, turn to TAG 002. If this does not resolve the problem, refer to [Section 4, Print Quality Samples](#). Compare the test prints with the print samples, and identify a sample having the same print flaw as the test prints; turn to the TAG listed under the sample.

Yes: Turn to TAG 002.

TAG 805: Black Prints

Possible Causes: *Contaminated toner/carrier mix*

Possible Defects (not listed in any particular order):

Charge corona
Printhead assembly
Connectors or wiring
VPCL board
RIGS board
High voltage power supply
Charge corona lead
Photoconductor
Developer
Charge corona terminal assembly

- 1** Turn the printer off and unplug the power cord.
- Verify that J/P23, J/P24, J/P41, and the charge corona high voltage lead are connected properly.
 - Refer to [Section 9, General Printer Maintenance](#), and perform the every-call cleaning procedure.
 - Clean the contacts on the charge corona.
 - Open the printer's top cover and install an interlock by-pass tool.
 - Run diagnostic test "[Photoconductor Seam Sensor Test](#)" on page 5-8.

Is the photoconductor belt covered with toner?

No: Loose connectors or contamination were at fault. Turn to TAG 002.

Yes: Continue.

- 2** Refer to [Section 9, General Printer Maintenance](#), and check the voltages.

Are the voltages correct?

No: Replace the high voltage power supply, then turn to TAG 002.

Yes: Continue.

- 3** **Has the photoconductor, charge corona, developer, and cleaner been replaced recently?**

No: Continue.

Yes: Go to [#6](#) in this TAG.

- 4** Replace the photoconductor and charge corona.

- Turn the printer on.
- Run test prints.

Has the problem been resolved?

No: Reinstall the original photoconductor and charge corona, then continue.

Yes: Turn to TAG 002.

-
- 5** Replace the developer, toner cartridge, and cleaner.
- Turn the printer on.
 - Run test prints.
- Has the problem been resolved?**
- No:** Reinstall the original developer and cleaner, then continue.
- Yes:** Turn to TAG 002. If the problem recurs, the toner/carrier mix may be old or contaminated.
-

- 6** Turn the printer off and unplug the power cord.
- Disconnect J/P41, J/P23, and J/P24.
 - Check P41-33 to P23-7 for continuity.
- Is there continuity?**
- No:** Repair or replace the connectors or wiring from P41-33 to P23-7, then turn to TAG 002.
- Yes:** Continue.
-

- 7** Check P41-30 to P24-4 for continuity.
- Is there continuity?**
- No:** Repair or replace the connectors or wiring from P41-30 to P24-4.
- Yes:** Continue.
-

- 8** Replace the charge corona terminal assembly.
- Run test prints.
- Has the problem been resolved?**
- No:** Continue.
- Yes:** Turn to TAG 002.
-

- 9** Replace the high voltage power supply.
- Run test prints.
- Has the problem been resolved?**
- No:** Reinstall the original high voltage power supply and continue.
- Yes:** Turn to TAG 002.
-

- 10** Replace the printhead assembly.
- Run test prints.
- Has the problem been resolved?**
- No:** Reinstall the original printhead assembly and continue.
- Yes:** Turn to TAG 002.
-

- 11** Replace the RIGS board.
- Run test prints.
- Has the problem been resolved?**
- No:** Replace the charge corona lead wiring, then turn to TAG 002.
- Yes:** Turn to TAG 002.
-

TAG 806: Prints with Dark Spots or Scratches

Possible Causes: *Paper path contamination*
Paper supply defects
Toner

Possible Defects (not listed in any particular order):
Photoconductor
Charge corona
Fuser
Developer
Cleaner

- 1** Turn the printer off and unplug the power cord.
- Refer to [Section 9, General Printer Maintenance](#), and perform the every-call cleaning procedure.
 - Turn the printer on.
 - Run test prints.

Has the problem been resolved?

No: Continue.

Yes: Contamination was at fault. Turn to TAG 002.

- 2** Refer to [Section 9, General Printer Maintenance](#) and check the voltages.

Are the voltages correct?

No: Replace the high voltage power supply, then turn to TAG 002.

Yes: Continue.

- 3** **Have the photoconductor, charge corona, fuser, cleaner, and developer with new toner cartridge been replaced recently?**

No: Continue.

Yes: Go to [#8](#) in this TAG.

- 4** Replace the photoconductor and charge corona.

- Run test prints.

Has the problem been resolved?

No: Reinstall the original photoconductor and charge corona and continue.

Yes: Turn to TAG 002.

- 5** Replace the cleaner.

- Run test prints.

Has the problem been resolved?

No: Reinstall the original cleaner and continue.

Yes: Turn to TAG 002.

-
- 6** Replace the fuser.
- Run test prints.
- Has the problem been resolved?**
- No:** Reinstall the original fuser and continue.
- Yes:** Turn to TAG 002.

-
- 7** Replace the developer and toner cartridge.
- Run test prints.
- Has the problem been resolved?**
- No:** Reinstall the original developer and continue.
- Yes:** Turn to TAG 002. If this problem recurs, the toner/carrier mix may be old or contaminated.

-
- 8** Inspect the paper being used for scratches or dark spots.
- Does the paper have any problems?**
- No:** Continue.
- Yes:** Replace the paper. Turn to TAG 002.

-
- 9** Inspect for damage or binding:
- Main drive motor gear
 - Main drive gear assembly
 - Developer coupling on the developer and the printer
- Are these mechanisms in good working order?**
- No:** Replace the defective parts, then turn to TAG 002.
- Yes:** Verify that the photoconductor, charge corona, developer, and fusers are new. If these items are new, defective or contaminated toner may be the cause of the problem. Replace the developer and cleaners with units from the printer's manufacturer, then turn to TAG 002.
-

TAG 807: Misregistered/Skewed Prints

! If this problem occurs in the duplex printing mode only, go to TAG 901.

Possible Causes: *Paper incorrectly loaded*
Wrong weight or type of paper loaded

Possible Defects (not listed in any particular order):

Upper cassette
Lower cassette
Upper paper guide assembly
Lower paper guide assembly
Paper timing guide assembly
Paper timing roller assembly
Upper pick-up roller assembly
Upper feed roller assembly
Upper pinch rollers
Lower feed roller assembly
Lower pick-up roller assembly
Lower pinch rollers
Paper feed drive belt
Paper feed idler assembly
Main drive gear assembly
VPCL board

! If the test pattern has a 20 line indicator at the top of the page, registration is correct when the twentieth line of the indicator is at the leading edge of the print (+ or - 2).

! If the problem varies from print to print, a mechanical binding malfunction may be at fault.

1

Inspect both paper cassettes for damage.

- Make sure the paper in the cassettes is loaded properly.
- Make sure the side and rear paper guides are positioned properly.
- Inspect both paper paths for contamination and remove any obstructions.
- Confirm that the paper in the cassettes meets paper specifications.
- Power-on-reset the printer.
- Remove and insert the cassette causing the problem. Confirm that the message, which displays on the operator's panel, corresponds to the paper size in the cassette. Refer to TAG 702.
- Run test prints from the upper cassette.

Is the problem with the upper cassette.

No: Go to #5 in this TAG.

Yes: Continue.

2

Remove the upper cassette.

- Power-on-reset the printer.
- Run test prints from the lower cassette.

Is the problem also with the lower cassette?

No: Go to #4 in this TAG.

Yes: Continue.

-
- 3** Turn the printer off and unplug the power cord.
- Inspect the following for damage or contamination:
 - Paper timing roller assembly
 - Upper paper guide assembly
 - Lower paper guide assembly
 - Paper timing guide assembly
 - Paper feed drive belt
 - Paper feed idler assembly
 - Main drive gear assembly

Are these parts clean and in good working order?

No: Repair or replace the parts as needed, then turn to TAG 002.

Yes: Go to #7 in this TAG.

- 4** Inspect the following for damage and contamination:
- Upper pick-up roller assembly
 - Upper feed roller assembly
 - Upper pinch rollers
 - Upper cassette

Are these parts clean and in good working order?

No: Repair or replace the parts as needed, then turn to TAG 002.

Yes: You have not isolated the problem. Return to the beginning of this TAG.

- 5** Remove the upper cassette.
- Power-on-reset the printer.
 - Run test prints from the lower cassette.

Is the problem with the lower cassette?

No: Incorrectly loaded paper was at fault. Turn to TAG 002.

Yes: Continue.

- 6** Inspect the following for damage or contamination:
- Lower pick-up roller assembly
 - Lower feed roller assembly
 - Lower pinch rollers
 - Lower cassette.

Are these parts clean and in good working order?

No: Repair or replace the parts as needed, then turn to TAG 002.

Yes: You have not isolated the problem. Return to the beginning of this TAG.

- 7** **Is misregistration the symptom of the problem?**

No: Skew problems can only result from mechanical causes. Return to the beginning of this TAG.

Yes: Continue.

TAG 807: Misregistered/Skewed Prints

8

Run test prints.

Is the amount of misregistration within + or - 2 lines of the 20-line indicator from the leading edge of the test print?

No: Continue.

Yes: The registration is within specification. Turn to TAG 002.

9

Adjust the registration as described in [Section 9, General Printer Maintenance](#).

Did adjusting the registration resolve the problem?

No: Replace the paper timing roller assembly, then turn to TAG 002. If this does not resolve the problem, replace the upper paper guide assembly or the paper timing guide, then turn to TAG 002.

Yes: Turn to TAG 002.

TAG 808: Prints Overtoned/Dark Vertical Streaks

Possible Causes: *Clogged cleaner*
Contaminated toner/carrier mix

Possible Defects (not listed in any particular order):
Cleaner
Photoconductor
Charge corona
High voltage power supply
Power control #2 board
VPCL board
Connectors or wiring
Developer

! Overtoned print and dark print problems are very similar. If this TAG does not resolve the problem, go to TAG 811.

-
- 1** Turn the printer off and unplug the power cord.
- Verify that J/P23, J/P12, J/P25, and J/P41 are connected properly.
 - Refer to [Section 9, General Printer Maintenance](#), and perform the every-call cleaning procedure.
 - Power-on-reset the printer.
 - Run test prints.
- Has the problem been resolved?**
- No:** Continue.
- Yes:** Contamination or loose connectors were at fault. Turn to TAG 002.
-
- 2** Refer to [Section 9, General Printer Maintenance](#), and check the voltages.
- Are the voltages correct?**
- No:** Replace the high voltage power supply, then turn to TAG 002.
- Yes:** Continue.
-
- 3** **Have the photoconductor, charge corona, cleaner, and developer with toner cartridge been replaced recently?**
- No:** Continue.
- Yes:** Go to [#7](#) in this TAG.
-
- 4** Replace the photoconductor and charge corona.
- Run test prints.
- Has the problem been resolved?**
- No:** Reinstall the original photoconductor and charge corona, then continue.
- Yes:** Run at least 200 test prints to detone the printer's engine, then turn to TAG 002.

TAG 808: Prints Overtone/Dark Vertical Streaks

5

Replace the cleaner.

- Run test prints.

Has the problem been resolved?

No: Reinstall the original cleaner and continue.

Yes: Turn to TAG 002.

6

Replace the developer with toner cartridge.

- Run test prints.

Has the problem been resolved?

No: Reinstall the original developer and continue.

Yes: Turn to TAG 002. If the problem recurs, the toner/carrier mix may be old or contaminated.

7

Turn the printer off.

- Open the front cover and install an interlock by-pass tool.
- Remove the developer.
- Power-on-reset the printer.
- Watch the toner motor coupling at the rear of the developer cavity.

Does the coupling turn continuously?

No: Go to #9 in this TAG.

Yes: Continue.

8

Turn off the printer and unplug the power cord.

- Disconnect J/P12 and J/P40.
- Check P40-31 to P12-5 for continuity.

Is there continuity?

No: Repair or replace the connectors or wiring from P40-31 to P12-5, then turn to TAG 002.

Yes: Replace the power control #2 board. If this resolves the problem, turn to TAG 002. If this doesn't resolve the problem, replace the VPCL board, then turn to TAG 002.

9

Reinstall the developer.

- Replace the VPCL board.
- Run test prints.

Has the problem been resolved?

No: Reinstall the old VPCL board and continue.

Yes: VPCL board was the problem. Turn to TAG 002.

10 Turn the printer off and unplug the power cord.

- Disconnect J/P41.
- Remove the developer.
- Check for continuity:
P41-44 to P25-2,
P41-47 to P25-3, and
P41-50 to P25-1.

Is there continuity at each?

No: Repair or replace the connectors or wiring from:
P41-44 to P25-2,
P41-47 to P25-3, or
P41-50 to P25-1;
then turn to TAG 002.

Yes: Continue.

11 Clean the printhead lens and toner patch sensor.

- Reinstall the developer.
- Reconnect J/P41.
- Run test prints.

Has the problem been resolved?

No: Continue.

Yes: Contamination was at fault. Turn to TAG 002.

12 Turn the printer off and unplug the power cord.

- Disconnect J/P41 and J/P24.
- Check P41-30 for continuity to ground.

Is there continuity?

No: Continue.

Yes: Repair or replace the connectors or wiring from P41-30 to P24-2, then turn to TAG 002.

13 Reconnect J/P24.

- Disconnect J/P23.
- Check P41-38 to P23-2 for continuity.

Is there continuity?

No: Repair or replace the connectors or wiring from P41-38 to P23-2, then turn to TAG 002.

Yes: Continue.

14 Disconnect J/P85.

- Remove the developer.
- Check P85-8 to J25-7 for continuity.

Is there continuity?

No: Repair or replace the connectors or wiring from P85-8 to J25-7, then turn to TAG 002.

Yes: Continue.

- 15** Reconnect J/P85.
- Reinstall the developer.
 - Replace the high voltage power supply.
 - Run test prints.

Has the problem been resolved?

No: Reinstall the original high voltage power supply and continue.

Yes: Turn to TAG 002.

- 16** Repair or replace the VPCL board.
- Run test prints.

Has the problem been resolved?

No: Reinstall the original VPCL board. Confirm that the photoconductor, charge corona, developer, and fusers are new. If these items are new, the toner/carrier mix may be old or contaminated. Replace the developer and cleaners with units from the printer's manufacturer. If this resolves the problem, turn to TAG 002. Otherwise, turn to TAG 811.

Yes: Turn to TAG 002.

TAG 809: Blurred or Smearred Vertical Streaks on Prints

Possible Defects (not listed in any particular order):

Photoconductor
Charge corona
Cleaner
Fuser
Vacuum transport
Fuser drive gear
Fuser drive idler and spring
Fuser drive belt
Main drive assembly
Printhead assembly
Power control #2 board

-
- 1** Turn the printer off and unplug the power cord.
- Verify that J/P23, J/P41, and J/P13 are connected properly.
 - Refer to [Section 9, General Printer Maintenance](#) and perform the every-call cleaning procedure.
 - Clean the printhead lens.
 - Turn the printer on.
 - Run test prints.

Has the problem been resolved?

No: Continue.

Yes: Contamination or loose connectors were at fault. Turn to TAG 002.

-
- 2** Refer to [Section 9, General Printer Maintenance](#) and check the voltages.

Are the voltages correct?

No: Replace the high voltage power supply, then turn to TAG 002.

Yes: Continue.

-
- 3** **Have the photoconductor, charge corona, cleaner, or fusers been replaced recently?**

No: Continue.

Yes: Go to [#7](#) in this TAG.

-
- 4** Replace the photoconductor and charge corona.

- Run test prints.

Has the problem been resolved?

No: Reinstall the original photoconductor and charge corona and continue.

Yes: Turn to TAG 002.

TAG 809: Blurred or Smearred Vertical Streaks on Prints

-
- 5** Replace the fuser.
- Run test prints.
- Has the problem been resolved?**
- No:** Reinstall the original fuser and continue.
- Yes:** Turn to TAG 002.

-
- 6** Replace the cleaner.
- Run test prints.
- Has the problem been resolved?**
- No:** Reinstall the original cleaner and continue.
- Yes:** Turn to TAG 002.

-
- 7** Check the following for damage:
- Vacuum transport
 - Vacuum transport assembly ozone filter
 - fuser drive gear on the fuser and fuser cavity
 - Fuser drive belt
 - Main drive assembly
 - cleaner drive belt
 - Cleaner drive idler assembly
 - Cleaner drive assembly
- Are they in good working order?**
- No:** Repair or replace the parts as needed, then turn to TAG 002.
- Yes:** Continue.

-
- 8** Open the printer's top cover and install an interlock by-pass tool.
- Turn the printer on.
 - Wait until the motor turns on, then proceed.
 - Verify the vacuum transport fan is running by placing a sheet of paper over the holes in the vacuum transport.
- Does the vacuum fan hold the paper?**
- No:** Go to [#10](#) in this TAG.
- Yes:** Continue.

-
- 9** Inspect the vacuum transport belts and gear for damage or binding.
- Is the vacuum transport in good working order?**
- No:** Repair or replace the vacuum transport, then turn to TAG 002.
- Yes:** Go to [#12](#) in this TAG.

-
- 10** Run test prints.
- ! Use extreme caution:**

TAG 809: Blurred or Smeared Vertical Streaks on Prints

- Check J/P22-1 to J/P22-2 for 100 Vac.

Is the voltage 100 Vac?

No: Continue.

Yes: Replace the vacuum transport, then turn to TAG 002.

TAG 809: Blurred or Smearred Vertical Streaks on Prints

11

Run test prints.

! Use extreme caution:

- Check J/P13-6 to J/P13-3 for 100 Vac.

Is the voltage 100 Vac?

No: Replace the power control #2 board, then turn to TAG 002.

Yes: Repair or replace the connectors or wiring from J22-1 to P13-6 or J22-2 to P13-3, then turn to TAG 002.

12

Inspect the fuser drive assembly and the fuser drive belt for damage or a slipping belt.

Are they in good working order?

No: Replace the parts that are defective, then turn to TAG 002.

Yes: Replace the printhead assembly, then turn to TAG 002.

TAG 810: Uneven Density or Dark Areas on Prints

Possible Defects (not listed in any particular order):

Photoconductor

Charge corona

Developer

Cleaner

1 Refer to [Section 9, General Printer Maintenance](#), and perform the every-call cleaning procedure.

- Turn the printer on.
- Run test prints.

Has the problem been resolved?

No: Continue.

Yes: Contamination was at fault. Turn to TAG 002.

2 Refer to [Section 9, General Printer Maintenance](#), and check the voltages.

Are the voltages correct?

No: Replace the high voltage power supply, then turn to TAG 002.

Yes: Continue.

3 **Have the photoconductor, charge corona, cleaner and developer with new toner cartridge been replaced recently?**

No: Continue.

Yes: Go to TAG 811.

4 Replace the photoconductor and charge corona.

- Run test prints.

Has the problem been resolved?

No: Reinstall the original photoconductor and charge corona and continue.

Yes: Turn to TAG 002.

5 Replace the cleaner.

- Run test prints.

Has the problem been resolved?

No: Reinstall the original cleaner and continue.

Yes: Turn to TAG 002.

6 Replace the developer and toner cartridge.

- Run test prints.

Has the problem been resolved?

No: Reinstall the original developer and toner cartridge, then turn to TAG 811.

Yes: Turn to TAG 002. If the problem recurs, the toner/carrier mix may be old or contaminated.

TAG 811: Background/Residual Images/Dark Prints

Possible Causes: *Contaminated toner/carrier mix*

Possible Defects (not listed in any particular order):

Photoconductor

Charge corona

Cleaner

Developer

Erase lamp assembly

High voltage power supply

Power control #2 board

Connectors or wiring

VPCL board

Charge corona terminal assembly

Cleaner terminal assembly

- 1** Turn the printer off and unplug the power cord.
- Verify J/P23, J/P24, J/P85, and the charge corona high voltage lead are connected properly.
 - Refer to [Section 9, General Printer Maintenance](#), and perform the every-call cleaning procedure.
 - Clean the contacts on the charge corona.
 - Clean the printhead lens and toner patch sensor located on the developer.
 - Turn the printer on.
 - Run test prints.

Has the problem been resolved?

No: Continue.

Yes: Contamination or a loose connector was at fault. Turn to TAG 002.

- 2** Refer to [Section 9, General Printer Maintenance](#), and check the voltages.

Are the voltages correct?

No: Replace the high voltage power supply, then turn to TAG 002.

Yes: Continue.

- 3** **Have the photoconductor, charge corona, cleaner and developer with new toner cartridge been replaced recently?**

No: Continue.

Yes: Go to #5 in this TAG.

- 4** Replace the photoconductor and charge corona.

- Run 200+ test prints, then evaluate the test print background.

Has the problem been resolved?

No: Reinstall the original photoconductor and charge corona and continue.

Yes: Turn to TAG 002.

-
- 5** Replace the developer and cleaner.
- Run test prints.
- Has the problem been resolved?**
- No:** Reinstall the original developer and cleaner and continue.
- Yes:** Turn to TAG 002.
-
- 6** Remove the photoconductor from the printer.
- Run diagnostic test “Erase Lamp Test” on page 5-10.
 - Watch the erase lamp while the test is running.
- Are all the erase lamps on?**
- No:** Continue
- Yes:** The VPCL was the problem, Turn to TAG 002.
-
- 7** Turn the printer off.
- Open the front cover and install an interlock by-pass tool.
 - Remove the developer.
 - Power-on-reset the printer.
 - Watch the toner motor coupling in the developer cavity.
- Does the coupling turn continuously before error message MC NO DEVELOPER #036 is displayed?**
- No:** Continue.
- Yes:** Go to #17 in this TAG.
-
- 8** Reinstall the developer.
- Replace the VPCL
 - Run test prints.
- Has the problem been resolved?**
- No:** Go to #10 in this TAG.
- Yes:** Continue.
-
- 9** Turn the printer off and unplug the power cord.
- Disconnect J/P41.
 - Remove the developer.
 - Check for continuity:
P41-44 to J25-2,
P41-47 to J25-3, and
P41-50 to J25-1.
- Is there continuity on each?**
- No:** Repair or replace the connectors or wiring:
P41-44 to J24-2,
P41-47 to J25-3, or
P41-50 to J25-1;
then turn to TAG 002.
- Yes:** Continue.

- 10** Turn the printer off and unplug the power cord.
- Disconnect J/P41 and J/P24.
 - Check P41-30 to P24-2 for continuity.
- Is there continuity?**
- No:** Repair or replace the connectors or wiring from P41-30 to P24-2, then turn to TAG 002.
- Yes:** Continue.
-

- 11** Reconnect J/P24.
- Disconnect J/P23.
 - Check P41-33 to P23-7 for continuity.
- Is there continuity?**
- No:** Continue.
- Yes:** Repair or replace the connectors or wiring from P41-33 to P23-7, then turn to TAG 002.
-

- 12** Reconnect J/P23.
- Disconnect J/P85 from the high voltage power supply.
 - Check P85-8 to J25-7 for continuity.
- Is there continuity?**
- No:** Repair or replace the connectors or wiring from P85-8 to J25-7, then turn to TAG 002.
- Yes:** Continue.
-

- 13** Reinstall the developer.
- Reconnect J/P85.
 - Disconnect J/P41 and J/P24.
 - Check P41-40 to P24-3 for continuity.
- Is there continuity?**
- No:** Repair or replace the connector or wiring from P41-40 to P24-3, then turn to TAG 002.
- Yes:** Continue.
-

- 14** Reconnect J/P41 and J/P24.
- Turn the printer on.
 - Run test prints.
 - Check TP4-40 for 0.5 Vdc while running the prints.
- Is the voltage 0.5 Vdc?**
- No:** Replace the VPCL board, then turn to TAG 002.
- Yes:** Continue.
-

- 15** Refer to [Section 9, General Printer Maintenance](#), and check the voltages.
- Are the voltages correct?**
- No:** Replace the high voltage power supply, then turn to TAG 002.
- Yes:** Continue.
-

16 Replace the VPCL board.
Has the problem been resolved?
No: Reinstall original VPCL board. Go back to #3 in this TAG. If this does not resolve the problem, the RIGS board, cleaner terminal assembly, or charge corona terminal assembly may be at fault. Determine which of these is at fault, correct the problem, then turn to TAG 002.
Yes: Turn to TAG 002.

17 Check J/P40-31 for 0 Vdc.
Is the voltage 0 Vdc?
No: Replace the power control #2 board, then turn to TAG 002.
Yes: Continue.

18 Turn the printer off and unplug the power cord.
• Disconnect J/P40.
• Check P40-31 for continuity to ground.
Is there continuity?
No: Replace the VPCL board, then turn to TAG 002.
Yes: Continue.

19 Disconnect J/P12.
• Check P40-31 and P12-5 for continuity to ground.
Is there continuity?
No: Replace the power control #2 board, then turn to TAG 002.
Yes: Repair or replace the connectors or wiring from P40-31 to P12-5, then turn to TAG 002.

TAG 812: Uneven or No Fusing on Prints

Possible Causes: *Wrong weight or type of paper loaded*

Possible Defects (not listed in any particular order):

Fuser
Connectors or wiring
AC power supply
VPCL board

- 1** Turn the printer off and unplug the power cord.
- Verify that J/P44, J/P4, J/P10, J/P11, J/P12, J/P40, J/P83, J/P91, and J/P8 are connected properly.
 - Refer to [Section 9, General Printer Maintenance](#), and perform the every-call cleaning procedure.
 - Turn the printer on.
 - Run test prints.

Has the problem been resolved?

No: Continue.

Yes: Contamination or loose connectors were at fault. Turn to TAG 002.

- 2** Refer to [Section 9, General Printer Maintenance](#), and check the voltages.

Are the voltages correct?

No: Replace the high voltage power supply, then turn to TAG 002.

Yes: Continue.

- 3** Have the fuser and developer with new toner cartridge been replaced recently?

No: Continue.

Yes: Go to [#6](#) in this TAG.

- 4** Replace the fuser.

- Run test prints.

Has the problem been resolved?

No: Reinstall the original fuser and continue.

Yes: Turn to TAG 002.

- 5** Replace the developer and toner cartridge.

- Run test prints.

Has the problem been resolved?

No: Reinstall the original developer and continue.

Yes: Turn to TAG 002.

-
- 6** Power-on-reset the printer.
- Watch through the output tray opening to see if the fuser lamp comes on.
- Does the lamp light within 1.5 minutes?**
- No:** Go to TAG 070.
- Yes:** Continue.
-
- 7** Run test prints.
- Does the print seem to be excessively dark or do the characters feel raised on the paper?**
- No:** Continue.
- Yes:** Go to TAG 808.
-
- 8** Confirm that the paper in the cassettes meets paper specifications.
- Is the paper within specification?**
- No:** Do not use this paper. Turn to TAG 002.
- Yes:** Continue.
-
- 9** Turn the printer off and unplug the power cord.
- Remove the fuser.
 - Disconnect J/P41.
 - Check P41-22 to P5-6 for continuity.
- Is there continuity?**
- No:** Repair or replace the connectors or wiring from P41-22 to P83-1, or J83-1 to P5-6, then turn to TAG 002.
- Yes:** Continue.
-
- 10** Check P41-21 to P5-7 for continuity.
- Is there continuity?**
- No:** Repair or replace the connectors or wiring from P41-21 to P83-2, or J83-2 to P5-7, then turn to TAG 002.
- Yes:** Continue.
-
- 11** Reinstall the fuser.
- Check P41-21 to P41-22 for resistance.
- Is the resistance between 1K Ω and 400 K Ω ?**
- No:** Replace the fuser. If this resolves the problem, turn to TAG 002. If this does not resolve the problem, replace the VPCL board, then turn to TAG 002.
- Yes:** Replace the VPCL board, then turn to TAG 002.
-

TAG 813: Residual Images on Prints

Possible Defects (not listed in any particular order):

Cleaner drive belt

Cleaner

High voltage power supply

Photoconductor

Erase lamp assembly

Developer

-
- 1** Turn the printer off and unplug the power cord.
- Refer to [Section 9, General Printer Maintenance](#), and perform the every-call cleaning procedure.
 - Turn the printer on.
 - Run test prints.

Has the problem been resolved?

No: Continue.

Yes: Contamination was at fault. Turn to TAG 002.

-
- 2** Open the printer's back cover.
- Remove the paper feed drive cover.
 - Check the cleaner drive belt.

Is the belt attached?

No: Repair or replace the cleaner drive belt, then turn to TAG 002.

Yes: Continue.

-
- 3** Refer to [Section 9, General Printer Maintenance](#), and check the voltages.

Are the voltages correct?

No: Replace the high voltage power supply, then turn to TAG 002.

Yes: Continue.

-
- 4** **Have the cleaner, developer with new toner cartridge, and photoconductor been replaced recently?**

No: Continue.

Yes: Go to [#8](#) in this TAG.

-
- 5** Replace the cleaner.
- Run test prints.
- Has the problem been resolved?**
- No:** Reinstall the original cleaner and continue.
- Yes:** Turn to TAG 002.

-
- 6** Replace the developer and toner cartridge.
- Run test prints.
- Has the problem been resolved?**
- No:** Reinstall the original developer and continue.
- Yes:** Turn to TAG 002.

-
- 7** Replace the photoconductor and charge corona.
- Run test prints.
- Has the problem been resolved?**
- No:** Reinstall the original photoconductor and charge corona, then continue.
- Yes:** Turn to TAG 002. If the problem recurs, the toner may be old or contaminated.

-
- 8** Turn the printer off and unplug the power cord.
- Disconnect J/P40 and J/P24.
 - Check P40-40 to P24-3 for continuity.
- Is there continuity?**
- No:** Repair or replace the connector or wiring from P40-40 to P24-3, then turn to TAG 002.
- Yes:** Continue.

-
- 9** Repair or replace the cleaner terminal assembly.
- Run test prints.
- Has the problem been resolved?**
- No:** Reinstall the original cleaner terminal assembly, then go back to [#5](#) in this TAG.
- Yes:** Turn to TAG 002.
-

TAG 815: Prints Resulting From Printhead Malfunctions

Symptoms: *Additional lines or missing lines on page.*

Possible Defects (not listed in any particular order):

*Printhead assembly
Connectors or wiring
RIGS board*

1 Turn off the printer and unplug the power cord.

- Replace wire harness 200.

Has the problem been resolved?

No: Continue.

Yes: Turn to TAG 002.

2 Turn off the printer and unplug the power cord.

- Replace the printhead assembly.

Has the problem been resolved?

No: Continue.

Yes: Turn to TAG 002.

3 Turn off the printer and unplug the power cord.

- Replace the RIGS board.

Has the problem been resolved?

No: Replace the RIGS board and continue.

Yes: RIGS board was at fault. Turn to TAG 002.

4 Turn off the printer and unplug the power cord.

- Replace the VPCL board.

Has the problem been resolved?

No: This is not a printhead malfunction. Replace the VPCL board and turn to TAG 808.

Yes: VPCL board was at fault. Turn to TAG 002.

TAG 900: Top Cover Interlock Malfunction, Duplex

ERROR MESSAGE:090

Possible Defects (not listed in any particular order):

Cover open sensor
VPCL board
Duplex control board #1
Connectors or wiring

! Complete TAG 600 before starting this TAG.

-
- 1** Turn the printer off and unplug the power cord.
- Verify that J/P306, J/P307, J/P309, and J/P318 are connected properly.
 - Confirm that the top and front covers are closing completely.
 - Power-on-reset the printer.
- Is error message 090 displayed?**
- No:** Loose connectors or obstructions were at fault. Turn to TAG 002.
- Yes:** Continue.

-
- 2** Open the printer's top cover and insert the interlock by-pass tool.
- Turn on the printer.
 - Check J/P309-3 on duplex control board #1 for +12 Vdc.
- Is the voltage +12 Vdc?**
- No:** Replace the duplex control board #1, then turn to TAG 002.
- Yes:** Continue.

-
- 3** Check J/P309-1 on duplex control board #1 for +12 Vdc.
- Is the voltage +12 Vdc?**
- No:** Continue.
- Yes:** Go to #5 in this TAG.

-
- 4** Turn the printer off and unplug the power cord.
- Disconnect J/P318 and J/P309.
 - Check the following for continuity:
 P309-1 to P318-2,
 P309-3 to P318-1, and
 P309-5 to P318-3.
- Is there continuity?**
- No:** Repair or replace the wiring or connectors from:
 P309-1 to P318-2,
 P309-3 to P318-1, or
 P309-5 to P318-3,
 then turn to TAG 002.
- Yes:** Replace the cover open sensor, then turn to TAG 002.

TAG 900: Top Cover Interlock Malfunction, Duplex

5

Turn on the printer.

- Check J/P36-1 on the VPCL board for +12 Vdc.

Is the voltage +12 Vdc?

No: Replace the duplex control board #1, then turn to TAG 002.

Yes: Replace the VPCL board, then turn to TAG 002.

TAG 901: Misregistration/Skewed Prints (Duplex)

Possible Causes: *Wrong weight or type of paper loaded*

Possible Defects (not listed in any particular order):

Duplex holding tray sensors

Duplex holding tray motor

Duplex drive/clutch

Pinch rollers A and B

Route separator

Duplex control board #2

Connectors or wiring

VPCL board

- ! Registration is correct when the top (+ or - 2) of the 20-line indicator, found on the top of a test print, is at the leading edge of the print.
- ! If the problem varies from print to print, suspect a mechanical binding problem. If problems exist in the simplex mode, go to TAG 807.

-
- 1** Verify that the upper and lower paper cassettes are not damaged.
- Confirm that the paper in the cassettes meets paper specifications.
 - Make sure the paper in both paper cassettes is loaded properly.
 - Make sure the side and rear paper guides in the paper cassettes are positioned properly.
 - Check both paper paths for obstructions or contamination.
 - Run test prints.

Has the problem been resolved?

No: Continue.

Yes: Turn to TAG 002.

-
- 2** Turn the printer off and unplug the power cord.
- Inspect the following for damage or contamination:
 - Duplex drive/clutch assembly
 - Timing belts
 - Upper paper guide assembly
 - Pinch roller springs
 - Route separator and springs
- Are these parts clean and in good working order?**
- No:** Repair or replace any damaged parts as needed, then turn to TAG 002.
- Yes:** Continue.

TAG 901: Misregistration/Skewed Prints (Duplex)

-
- 3** Verify that J/P305, J/P310, J/P311, J/P312, J/P320, J/P321, and J/P322 are connected properly to duplex control board #2.
- Verify that J/P306, J/P307, J/P308, J/P309, and J/P324 are connected properly to duplex control board #1.
 - Verify that J/P315 and J/P316 are connected properly to the “A” and “C” roller clutches.
 - Run test prints in duplex.

Did the test indicate an error message?

No: Registration or skew problems can only result from mechanical causes. Return to the beginning of this TAG.

Yes: Continue.

- 4** **Did the side guides in the duplex tray move in and out while the test was running?**

No: Go to #8 in this TAG.

Yes: Continue.

- 5** Check J/P312-1 on duplex control board #2 for +12 Vdc.

Is the voltage +12 Vdc?

No: Replace duplex control board #2, then turn to TAG 002.

Yes: Continue.

- 6** Manually move the side guides in the duplex tray to the inside positions.

- Check J/P312-2 on duplex control board #2 for 0 Vdc.

Is the voltage 0 Vdc?

No: Continue.

Yes: Replace duplex control board #2, then turn to TAG 002.

- 7** Turn the printer off and unplug the power cord.

- Disconnect J/P320 and J/P312.
- Check the following for continuity:
 - P312-1 to P320-1,
 - P312-2 to P320-2, and
 - P312-3 to P320-3.

Is there continuity?

No: Repair or replace the wiring or connectors from:

- P312-1 to P320-1,
 - P312-2 to P320-2, or
 - P312-3 to P320-3,
- then turn to TAG 002.

Yes: Replace the side sensor. If this resolves the problem, turn to TAG 002. If this does not resolve the problem, replace duplex control board #2, then turn to TAG 002.

- 8** Run diagnostic test “[Duplex Sensor Tests](#)” on page 5-12.

Did the Duplex Sensor Test indicate a duplex tray paper sensor problem?

No: Continue.

Yes: Go to #13 in this TAG.

9 Turn the printer off.

- Disconnect J/P312 and J/P321.
- Check P312-7 to J321-1 for continuity.

Is there continuity?

No: Repair or replace the wiring or connectors from P312-7 to J321-1, then turn to TAG 002.

Yes: Continue.

10 Check P312-8 to J321-2 for continuity.

Is there continuity?

No: Repair or replace the wiring or connectors from P312-8 to J321-2, then turn to TAG 002.

Yes: Continue.

11 Check P312-9 to J321-3 for continuity.

Is there continuity?

No: Repair or replace the wiring or connectors from P312-9 to J321-3, then turn to TAG 002.

Yes: Continue.

12 Check P312-10 to J321-4 for continuity.

Is there continuity?

No: Repair or replace the wiring or connectors from P312-10 to J321-4, then turn to TAG 002.

Yes: Replace duplex control board #2. If this resolves the problem, turn to TAG 002. If this does not resolve the problem, replace the registration motor, then turn to TAG 002.

13 Check J/P312-4 for +12 Vdc.

Is the voltage +12 Vdc?

No: Replace duplex control board #2, then turn to TAG 002.

Yes: Continue.

14 Manually activate the duplex tray paper sensor.

- Check J/P312-5 for 0 Vdc.

Is the voltage 0 Vdc?

No: Replace the duplex tray paper sensor. If this resolves the problem, turn to TAG 002. If this doesn't resolve the problem, repair or replace the wiring or connectors from:

- P312-4 to J322-1,
- P312-5 to J322-2, or
- P312-6 to J322-3,

then turn to TAG 002.

Yes: Continue.

TAG 901: Misregistration/Skewed Prints (Duplex)

- 15** Manually activate the duplex tray paper sensor.
- Check J/P36-6 on the VPCL board for 0 Vdc.

Is the voltage 0 Vdc?

No: Replace duplex control board #2. If this resolves the problem, turn to TAG 002. If this doesn't resolve the problem, repair or replace the wiring or connectors from P311-7 to J/P305-11 to P36-4, then turn to TAG 002.

Yes: Replace the VPCL board, then turn to TAG 002.

TAG 902: Paper Jam in Duplex Area

**ERROR MESSAGE:PAPER JAM 027 IN DUPLEX AREA
PAPER JAM 060 DUPLEX ROLLER
PAPER JAM 061 DUPLEX PATH
PAPER JAM 062 DUPLEX TRAY**

Possible Causes: *Paper incorrectly loaded
Paper path not clear*

Possible Defects (not listed in any particular order):
*Duplex drive/clutch
“A” roller clutch
Duplex input solenoid
“C” roller clutch
Duplex feed motor
Duplex control board #1
Connectors or wiring*

- 1** Turn the printer off and unplug the power cord.
- Verify that J/P306, J/P307, J/P308, J/P309, J/P313, J/P314, J/P315, J/P316, J/P317, and J/P319 are connected properly.
 - Check the following components for damage:
 - Duplex drive/clutch
 - Timing belts
 - Route separator
 - Power-on-reset the printer.

Has the problem been resolved?

No: Continue.

Yes: Loose connectors were at fault. Turn to TAG 002.

- 2** Turn on the printer.
- Run diagnostic test [“Duplex Sensor Tests” on page 5-12.](#)

Is the duplex paper path sensor in good working order?

No: Continue.

Yes: Go to [#7](#) in this TAG.

- 3** Turn the printer off.
- Disconnect J/P309.
 - Turn on the printer.
 - Check J309-4 on duplex control board #1 for +12 Vdc.

Is the voltage +12 Vdc?

No: Replace duplex control board #1, then turn to TAG 002.

Yes: Continue.

TAG 902: Paper Jam in Duplex Area

- 4** Check J/P309-2 on duplex control board #1 for +12 Vdc.
Is the voltage +12 Vdc?
No: Replace duplex control board #1, then turn to TAG 002.
Yes: Continue.
-

- 5** Turn the printer off.
- Reconnect J/P309.
 - Disconnect J/P319.
 - Turn the printer on.
 - Check J319-1 for +12 Vdc.
- Is the voltage +12 Vdc?**
No: Repair or replace the wiring or connectors from P309-4 to J319-1, then turn to TAG 002.
Yes: Continue.
-

- 6** Check J319-2 for +12 Vdc.
Is the voltage +12 Vdc?
No: Repair or replace the wiring or connectors from P309-2 to J319-2, then turn to TAG 002.
Yes: Replace the paper pass sensor, then turn to TAG 002.
-

- 7** Turn the printer on.
- Run diagnostic test [“Duplex Sensor Tests” on page 5-12.](#)
- Is the “A” roller clutch in good working order?**
No: Continue.
Yes: Go to [#10](#) in this TAG.
-

- 8** Turn the printer off.
- Disconnect J/P308.
 - Turn the printer on.
 - Check J308-3 on the duplex control board #1 for +24 Vdc.
- Is the voltage +24 Vdc?**
No: Replace duplex control board #1, then turn to TAG 002.
Yes: Continue.
-

- 9** Turn the printer off.
- Reconnect J/P308.
 - Disconnect J/P316.
 - Turn the printer on.
 - Check P316-1 for +24 Vdc.
- Is the voltage +24 Vdc?**
No: Repair or replace the wiring or connectors from P308-3 to J316-1, then turn to TAG 002.
Yes: Replace the “A” roller clutch, then turn to TAG 002.

-
- 10** Turn the printer on.
- Run diagnostic test “Duplex Clutch Tests” on page 5-13.
- Is the input solenoid in good working order?**
- No:** Continue.
- Yes:** Go to #13 in this TAG.

-
- 11** Turn off the printer.
- Disconnect J/P308.
 - Turn on the printer.
 - Check J308-1 and J308-5 for +24 Vdc.
- Is the voltage +24 Vdc?**
- No:** Replace duplex control board #1, then turn to TAG 002.
- Yes:** Continue.

-
- 12** Disconnect J/P314.
- Check for continuity:
P308-1 to J314-1, and
P308-5 to J314-2.
- Is there continuity?**
- No:** Repair or replace the wiring or connectors from:
P308-1 to J314-1, or
P308-5 to J314-2,
then turn to TAG 002.
- Yes:** Replace the input solenoid, then turn to TAG 002.

-
- 13** Turn the printer on.
- Run diagnostic test “Duplex Clutch Tests” on page 5-13.
- Is the C roller solenoid in good working order?**
- No:** Continue.
- Yes:** Go to #16 in this TAG.

-
- 14** Turn off the printer.
- Disconnect J/P308.
 - Turn on the printer.
 - Check J308-2 and J308-6 for +24 Vdc.
- Is the voltage +24 Vdc?**
- No:** Replace duplex control board #1, then turn to TAG 002.
- Yes:** Continue.

TAG 902: Paper Jam in Duplex Area

15

Disconnect J/P315.

- Check the following for continuity:
P308-2 to P315-1, and
P308-6 to P315-2.

Is there continuity?

No: Repair or replace the wiring or connectors from:
P308-2 to P315-1, or
P308-6 to P315-2,
then turn to TAG 002.

Yes: Replace the “C” roller solenoid, then turn to TAG 002.

16

Turn the printer on.

- Run diagnostic test “[Duplex Motor Tests](#)” on page 5-11.

Is the feed motor in good working order?

No: Continue.

Yes: Go to [#21](#) in this TAG.

17

Turn the printer off.

- Disconnect J/P309.
- Check P309-7 to P309-8 for continuity.

Is there continuity?

No: Go to [#19](#) in this TAG.

Yes: Continue.

18

Check P309-9 to P309-10 for continuity.

Is there continuity?

No: Continue.

Yes: Replace duplex control board #1, then turn to TAG 002.

19

Disconnect J/P313.

- Check the following for continuity:
P309-7 to J313-1,
P309-8 to J313-2,
P309-9 to J313-3, and
P309-10 to J313-4.

Is there continuity?

No: Repair or replace the wiring or connectors from P309 to J313 that have no continuity, then turn to TAG 002.

Yes: Continue.

20 Check the following for continuity:
P313-1 to P313-2, and
P313-3 to P313-4.

Is there continuity?

No: Replace the route motor, then turn to TAG 002.

Yes: Replace the duplex control board #1, then turn to TAG 002.

21 Turn the printer on.

- Check J/P306-3 to J/P306-4 for +5 Vdc.

Is the voltage +5 Vdc?

No: Repair or replace the wiring or connectors from P306-3 to J/P331-3 to P330-3, then turn to TAG 002.

Yes: Continue.

22 Check J/P306-2 to J/P306-4 for +12 Vdc.

Is the voltage +12 Vdc?

No: Repair or replace the wiring or connectors from P306-2 to J/P331-2 to P330-2, then turn to TAG 002.

Yes: Continue.

23 Check J/P306-1 to J/P306-4 for +24 Vdc.

Is the voltage +24 Vdc?

No: Repair or replace the wiring or connectors from P306-1 to J/P331-1 to P330-1, then turn to TAG 002.

Yes: Return to the beginning of this TAG.

TAG 902: Paper Jam in Duplex Area

***Print Quality
Samples***

Contents

Print Quality Samples

| | |
|---|------|
| Sample 1: Good Quality Print | 4-4 |
| Sample 2: Washout. | 4-5 |
| Sample 3: Blank Print. | 4-6 |
| Sample 4: Light Print | 4-7 |
| Sample 5: Light Print With Background | 4-8 |
| Sample 6: Voids or White Spots | 4-9 |
| Sample 7: Light Vertical Streaks | 4-10 |
| Sample 8: Blank Vertical Bands. | 4-11 |
| Sample 9: Light Horizontal Bands | 4-12 |
| Sample 10: Black or Dark Print | 4-13 |
| Sample 11: Dark Specks, Lines, or Areas | 4-14 |
| Sample 12: Dark Vertical Lines | 4-15 |
| Sample 13: Skewed Prints | 4-16 |
| Sample 14: Misregistration. | 4-17 |
| Sample 15: Overtoned Print | 4-18 |
| Sample 16: Blurred Images or Characters | 4-19 |
| Sample 17: Varying Print Density | 4-20 |
| Sample 18: Background | 4-21 |
| Sample 19: Residual Images | 4-22 |
| Sample 20: Wrinkles | 4-23 |
| Sample 21: Fusing Problems | 4-24 |

Print Quality Samples

This section contains flawed test prints, along with a good test print for comparison. Compare print samples from your customer's print job or from test prints you've run with the samples in this section. If you find a match, note the TAG (i.e., troubleshooting procedure) listed under the sample. Turn to that TAG to begin troubleshooting. All of the TAGs are contained in [Section 3, Troubleshooting Analysis Guides](#).

If your customer's prints show more than one problem, resolve them one at a time, in the order in which they are listed in this section.

Sample 1: Good Quality Print

Sample 1: Good Quality Print

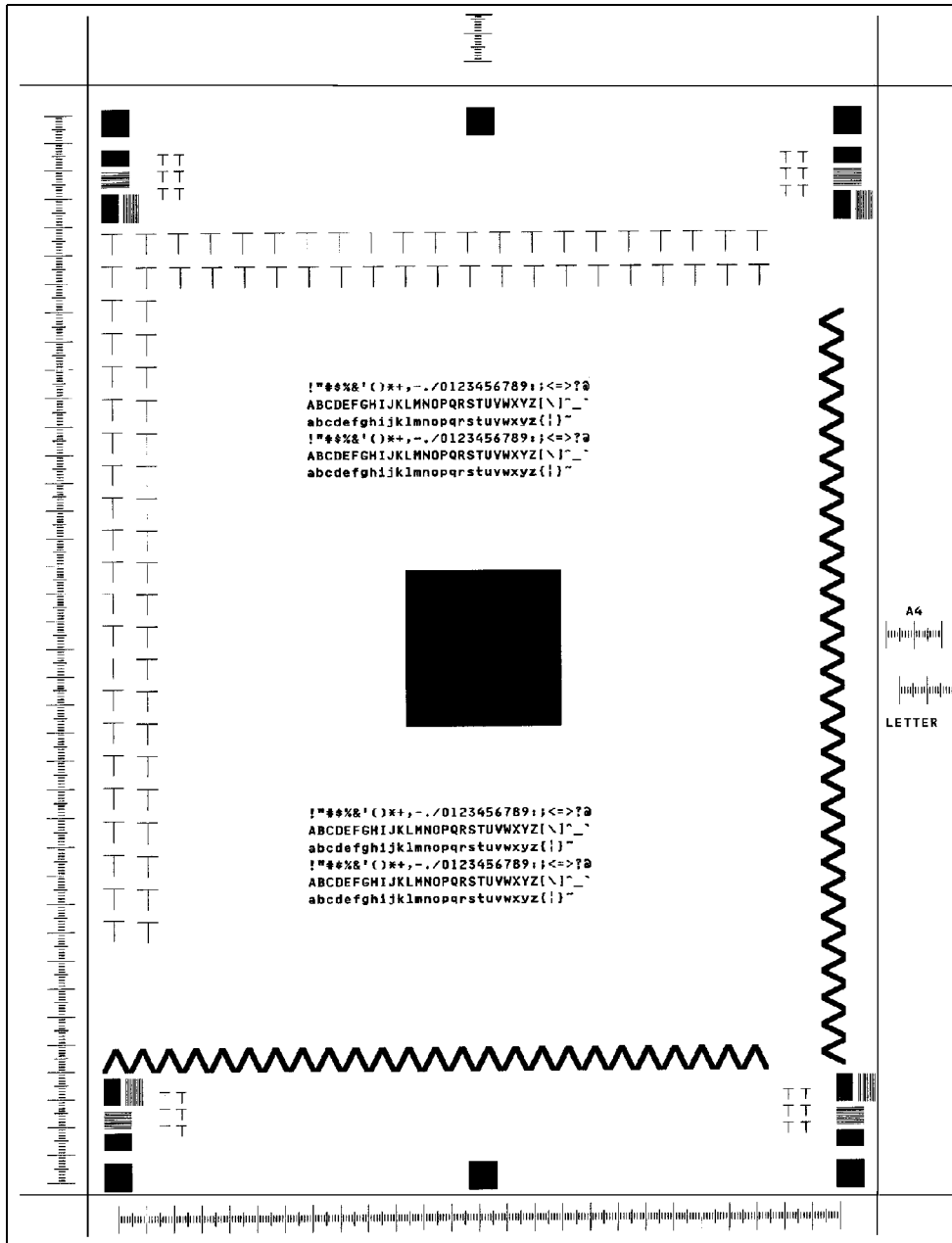

Description: Good, properly registered print.

Sample 2: Washout

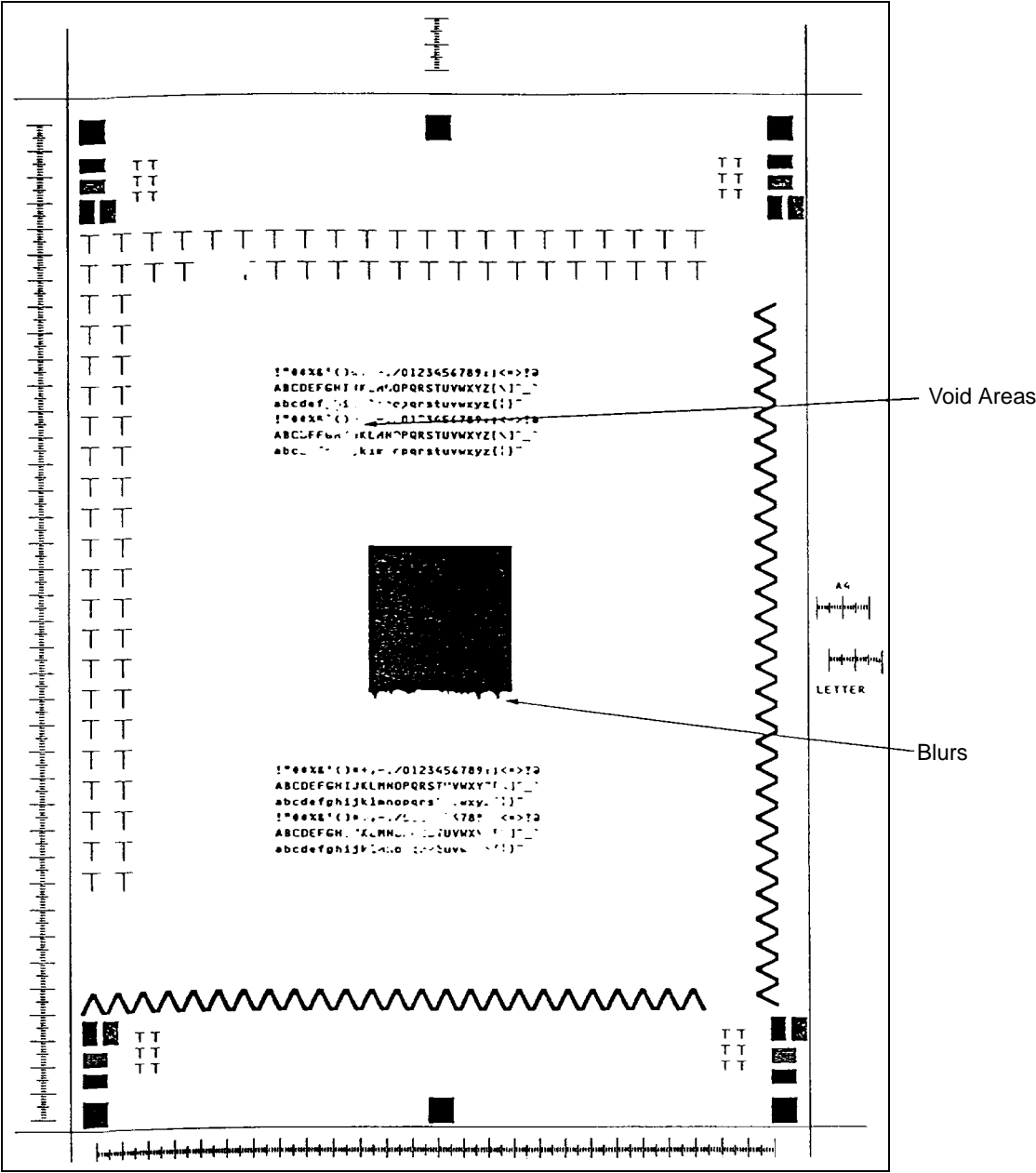

Description: Void areas, light spots, or blurs. This is a composite of the possible symptoms.

Go to TAG 801, 802, 809, or 810.

Sample 3: Blank Print

Sample 3: Blank Print

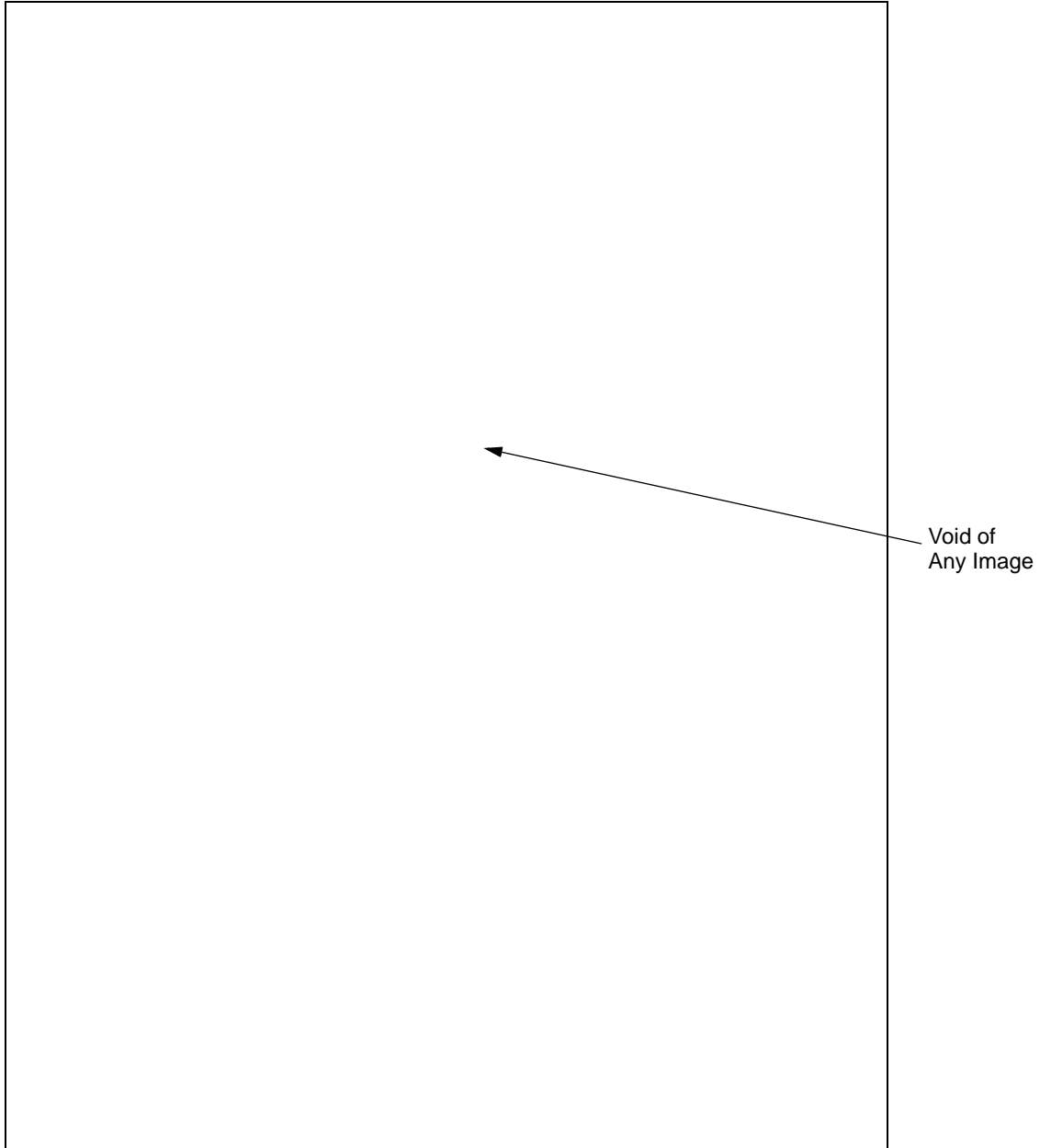

Description: No images or characters. The paper is not discolored.

Go to TAG 800, 815.

Sample 5: Light Print With Background

Sample 5: Light Print With Background

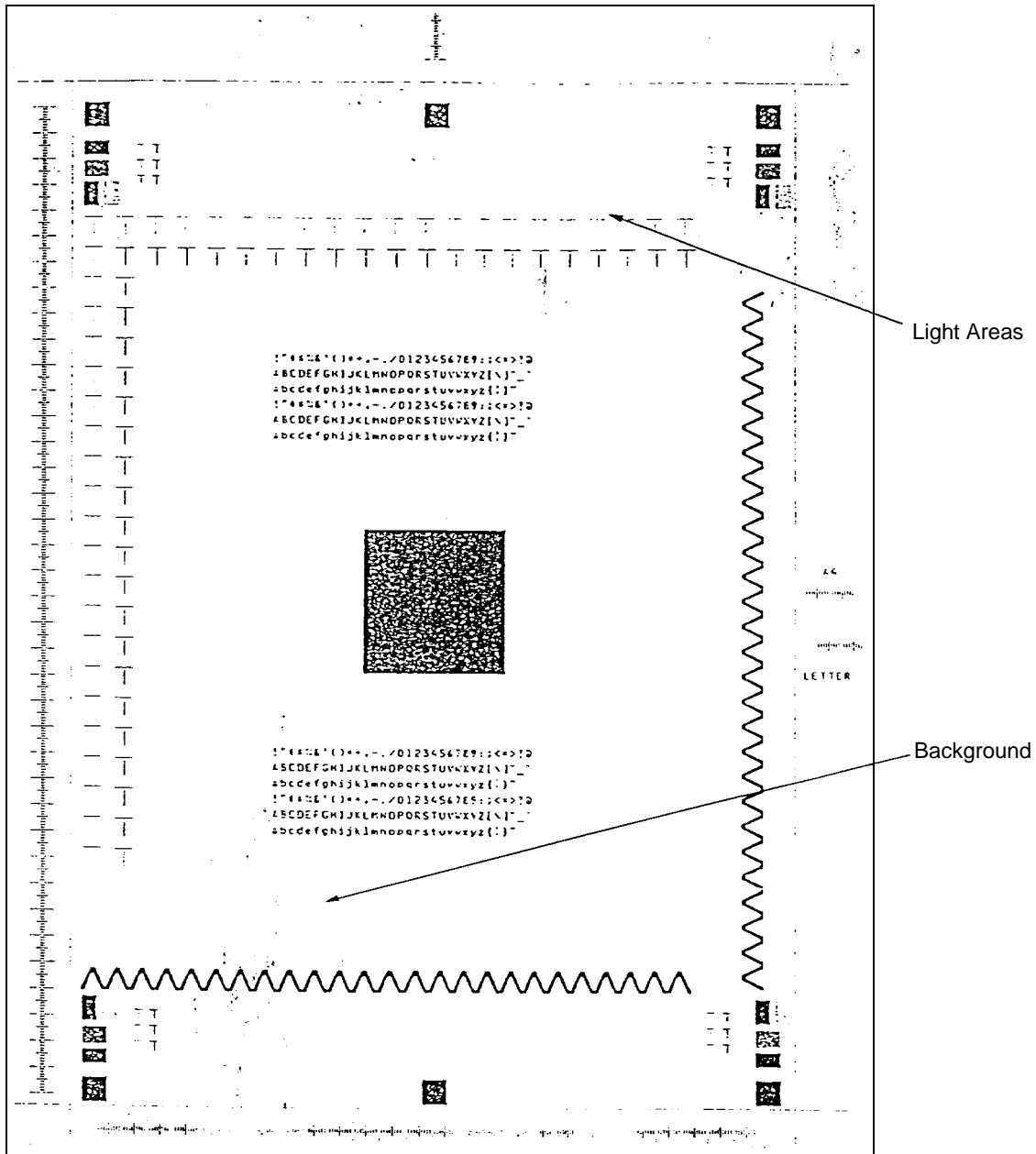

Description: Images or characters lighter than normal, ranging from a few dark specks to a large speckled background.

Go to TAG 811.

Sample 6: Voids or White Spots

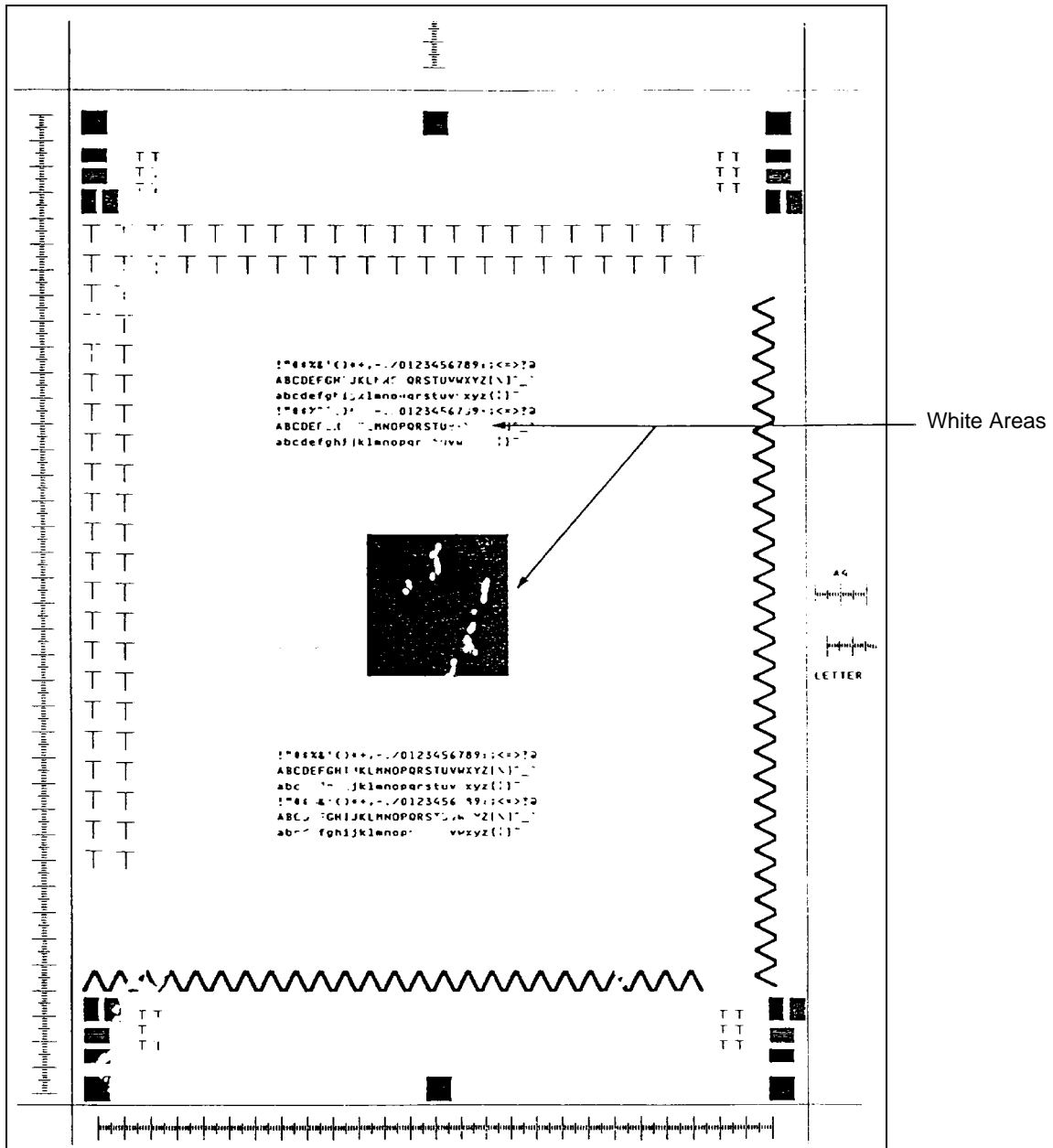

Description: Voids or white spots in image areas.

Go to TAG 802.

Sample 7: Light Vertical Streaks

Sample 7: Light Vertical Streaks

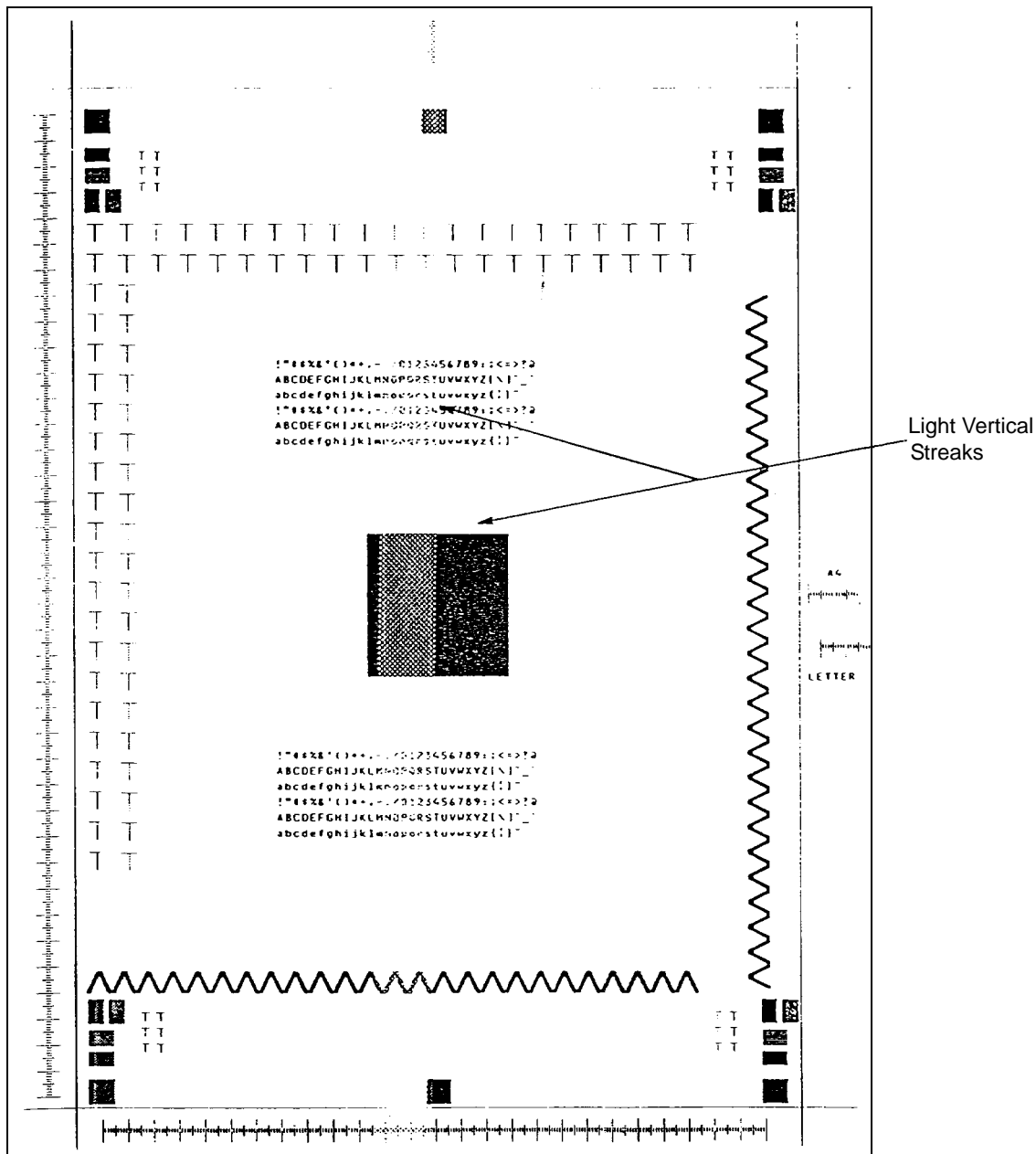

Description: One or more light vertical streaked areas of varying widths.

Go to TAG 803.

Sample 8: Blank Vertical Bands

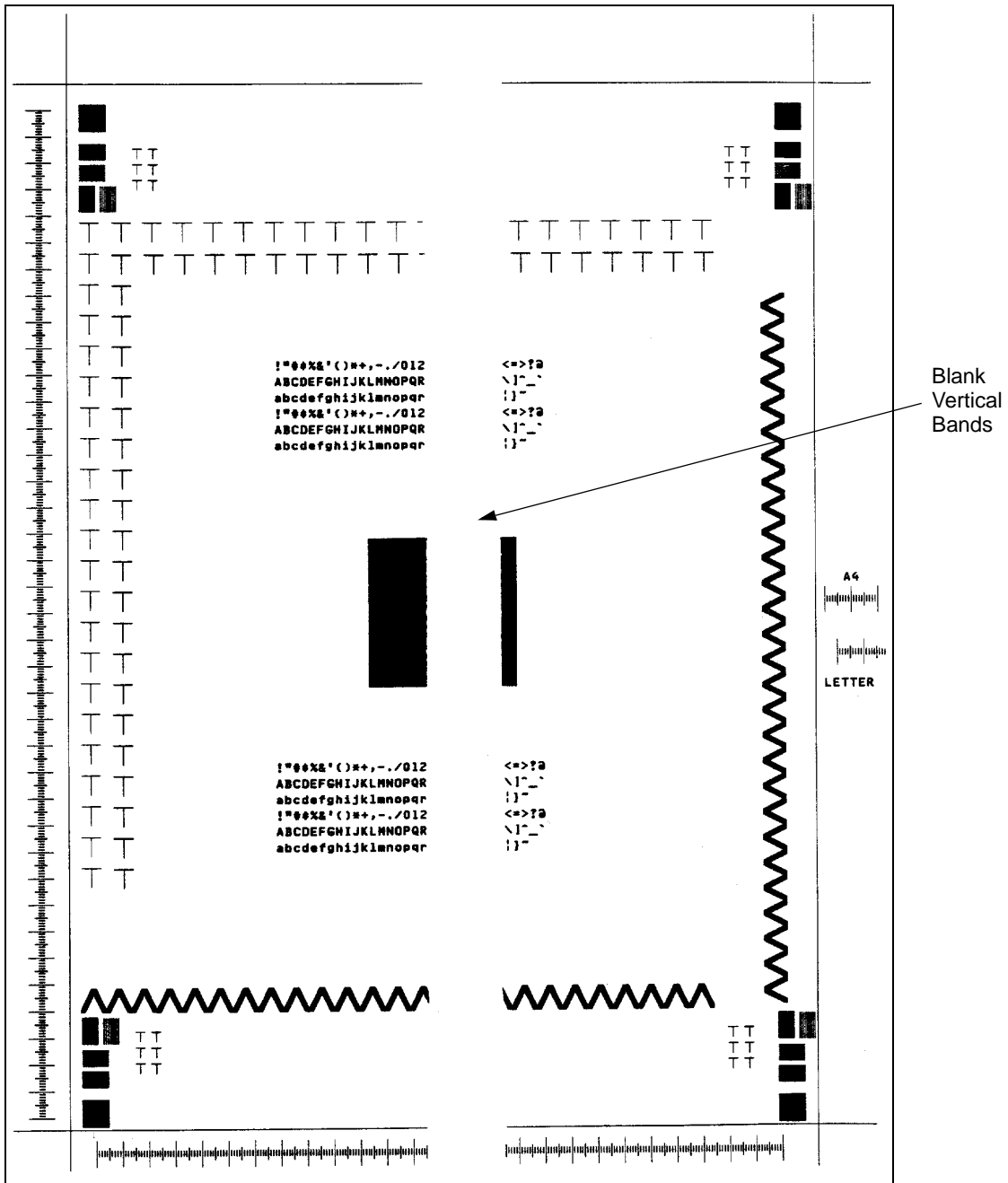

Description: One or more vertical blank bands of varying widths extend over the entire length.

Go to TAG 803.

Sample 9: Light Horizontal Bands

Sample 9: Light Horizontal Bands

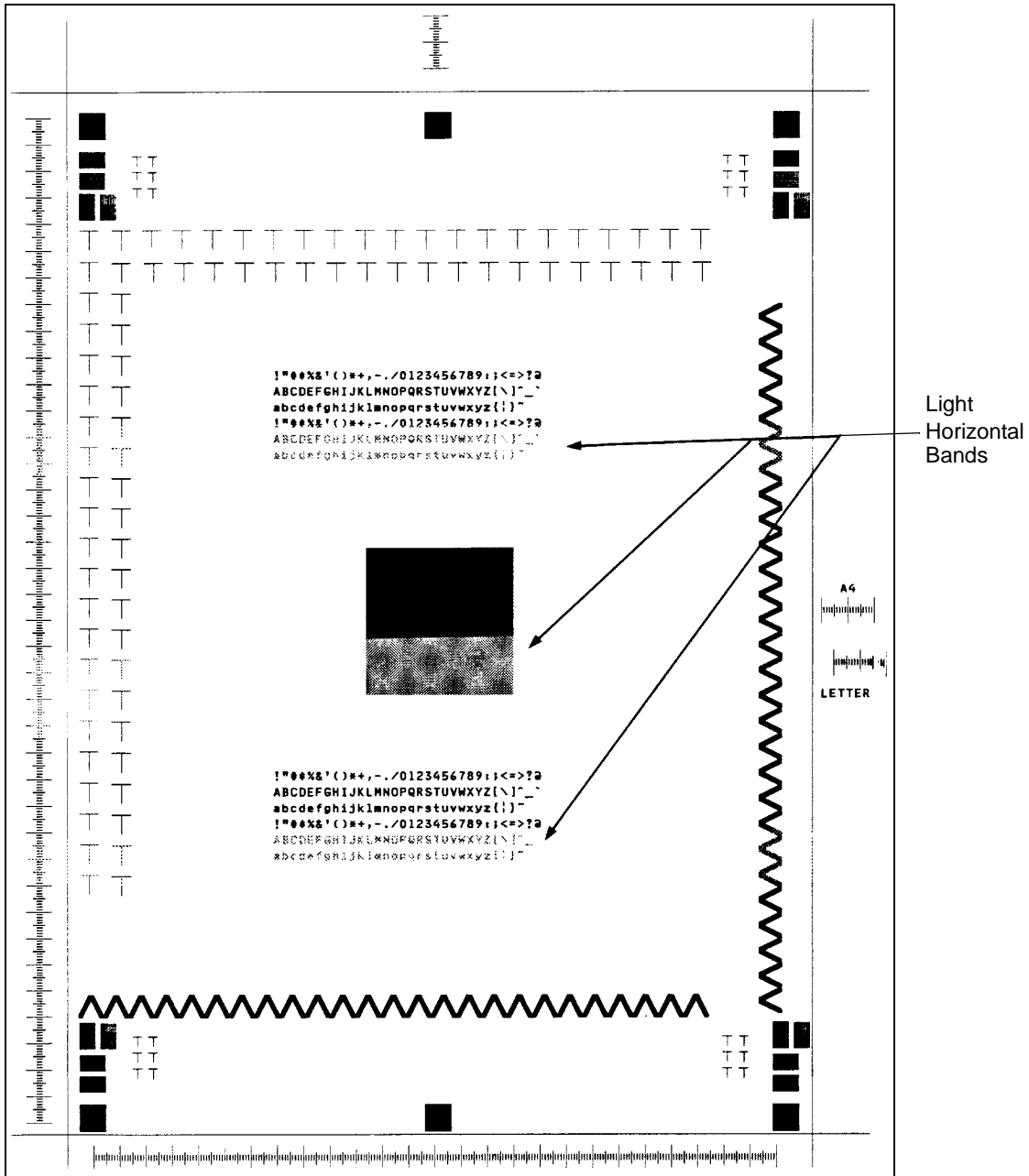

Description: One or more light horizontal bands of varying width.

Go to TAG 804.

Sample 10: Black or Dark Print



Excessively
Dark or Black
Print

Description: Black or very dark with no visible images.

Go to TAG 805, 811.

Sample 11: Dark Specks, Lines, or Areas

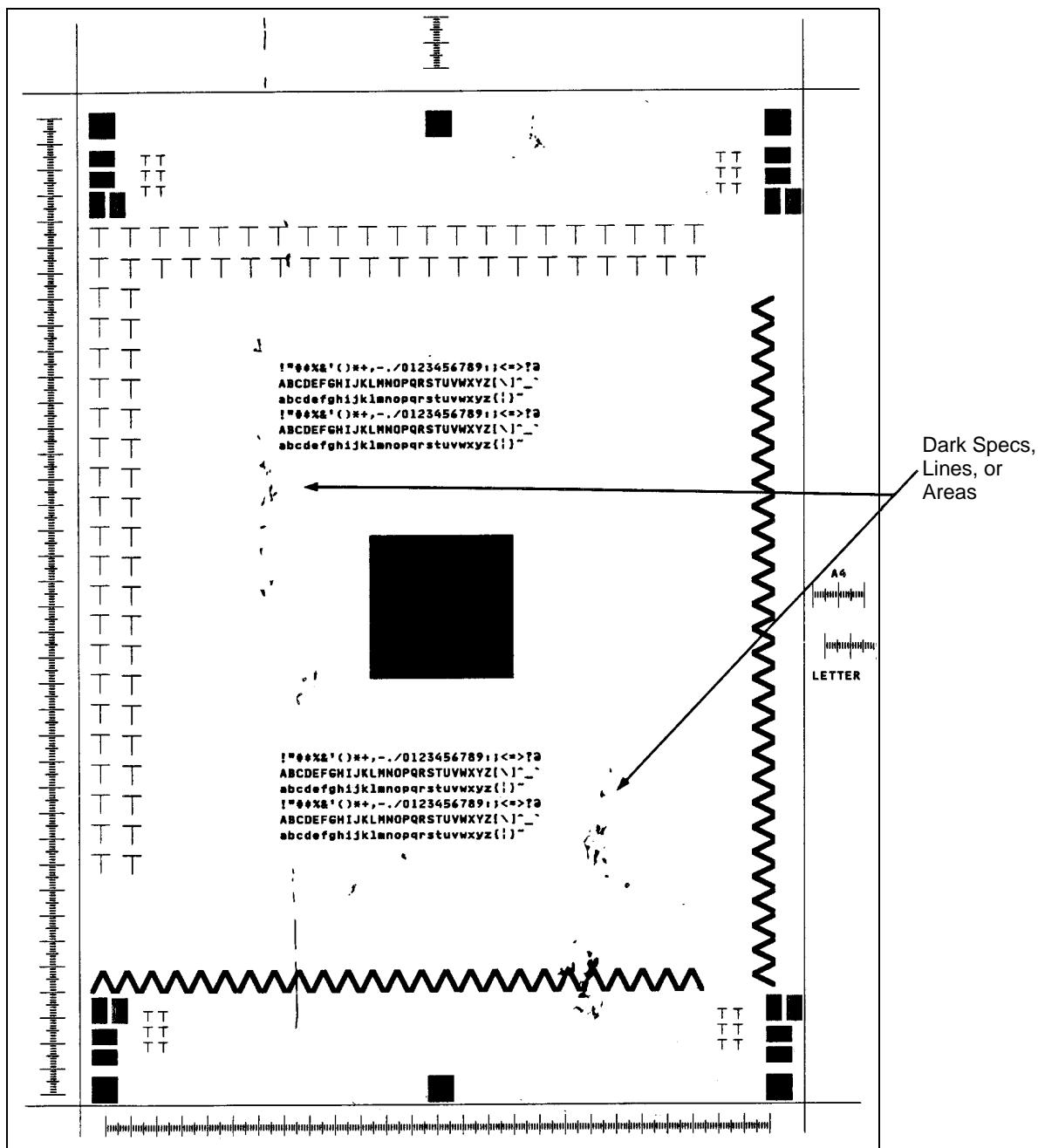

Description: Dark specks or lines (like scratches), some in the same place on each print.

Go to TAG 806, 810.

Sample 12: Dark Vertical Lines

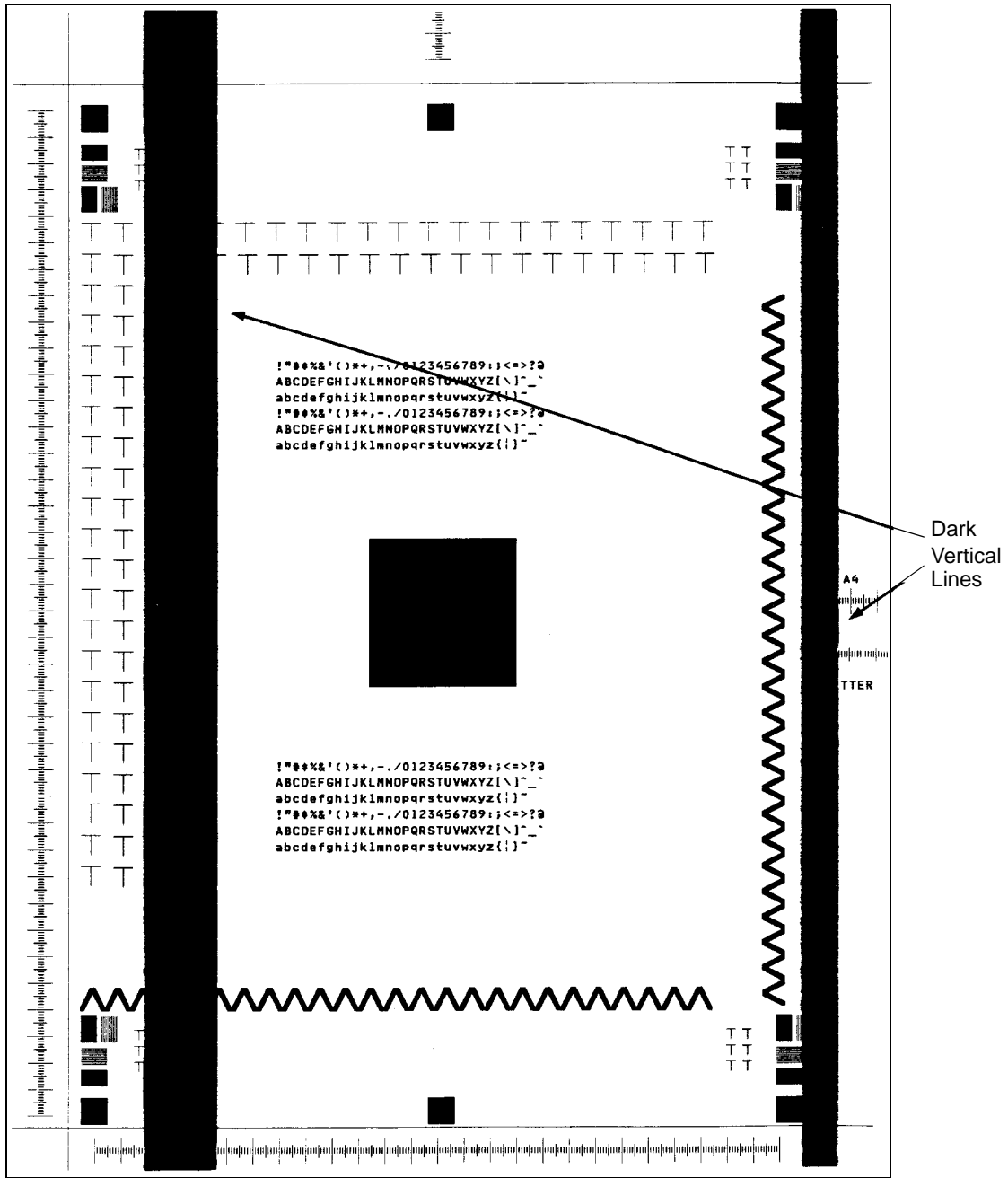

Description: One or more dark lines of varying density. If the image can be rubbed off, go to TAG 812. If the image cannot be rubbed off, go to TAG 808.

Go to TAG 812, 808.

Sample 13: Skewed Prints

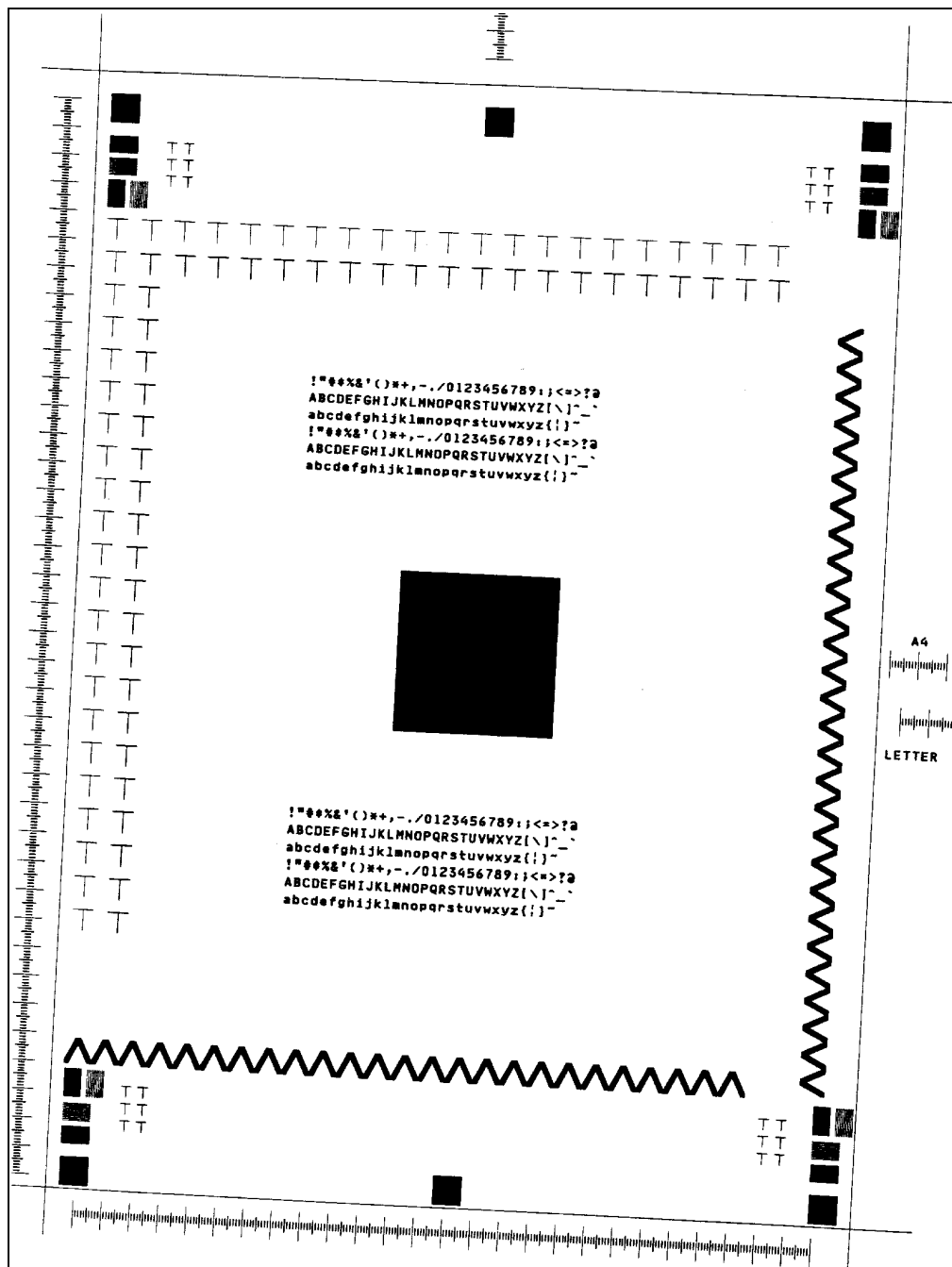

Image is Crooked on Page

Description: The entire image is not located squarely on the paper.

Go to TAG 807 for simplex.

Go to TAG 901 for duplex.

Sample 14: Misregistration

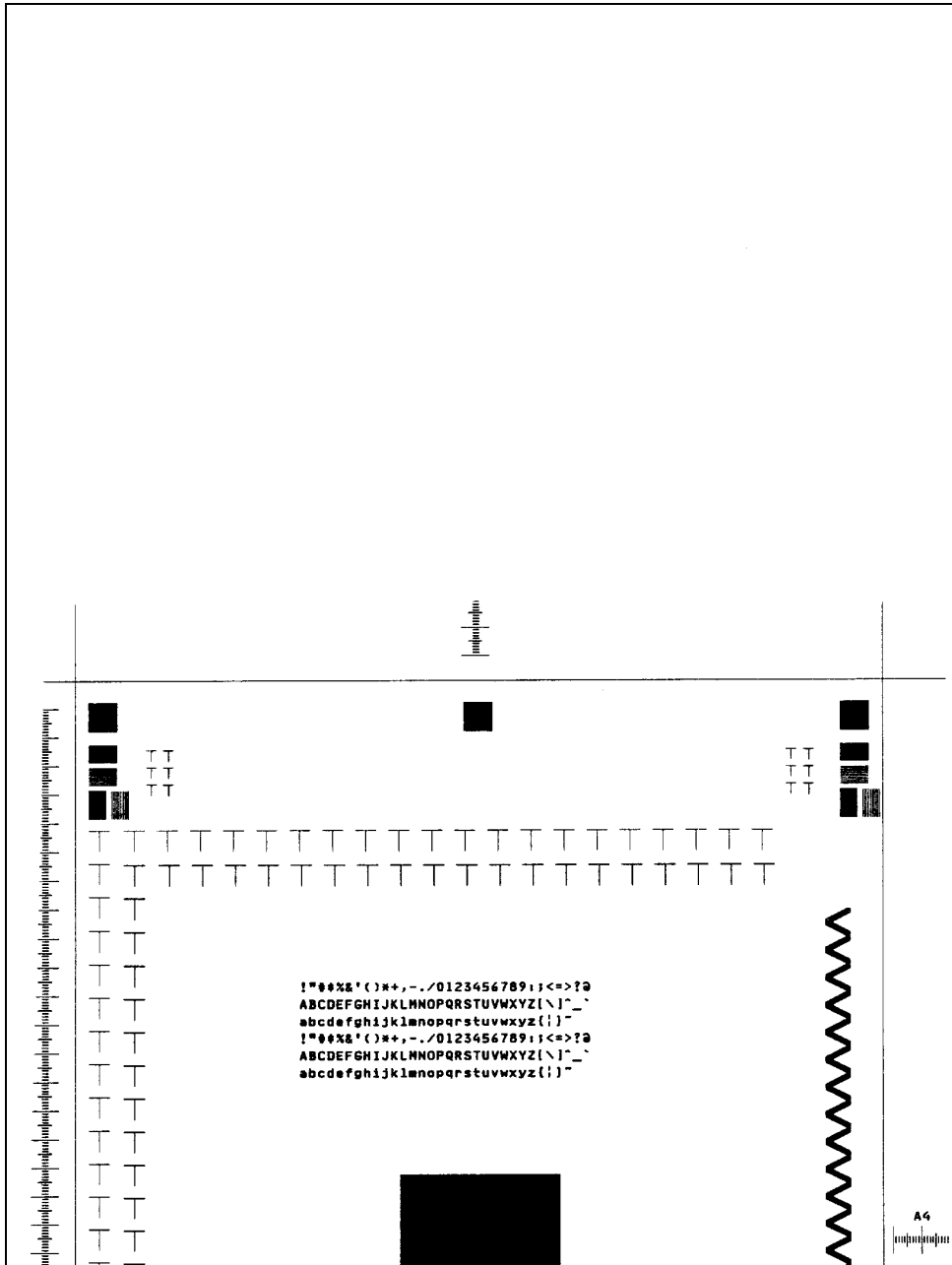
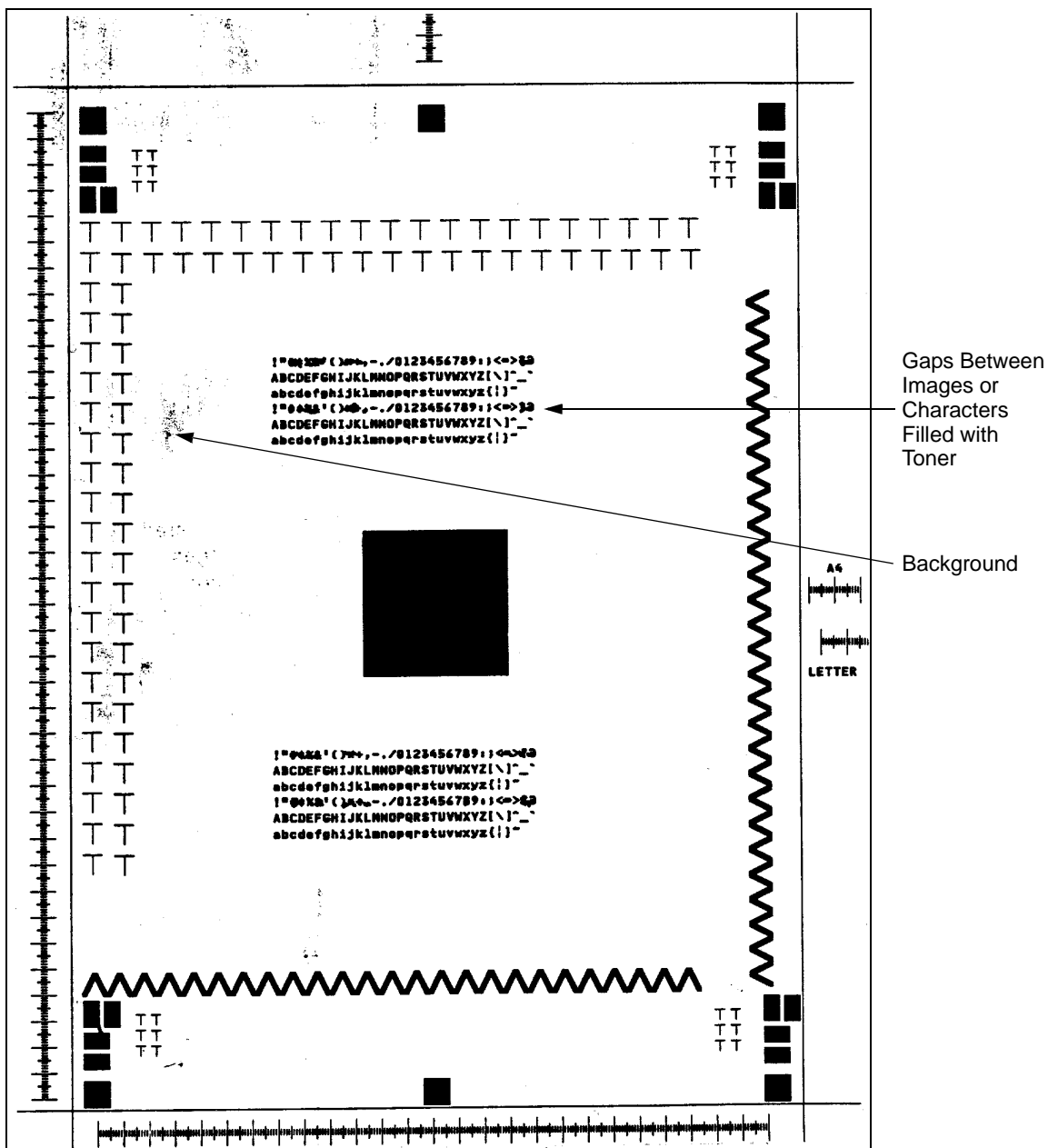

Image not
Located
Properly from
Leading Edge
of Paper

Description: The entire image is not correctly located from the leading edge of the paper. The top or bottom image area may be missing.

Go to TAG 807 for simplex. Go to TAG 901 for duplex.

Sample 15: Overtone Print



Description: Similar to dark print quality problems. Narrow gaps between letters and images may be filled with toner. Excess toner may be present on the surface of the print. Extra toner can also cause background in the white areas.

Go to TAG 808.

Sample 16: Blurred Images or Characters

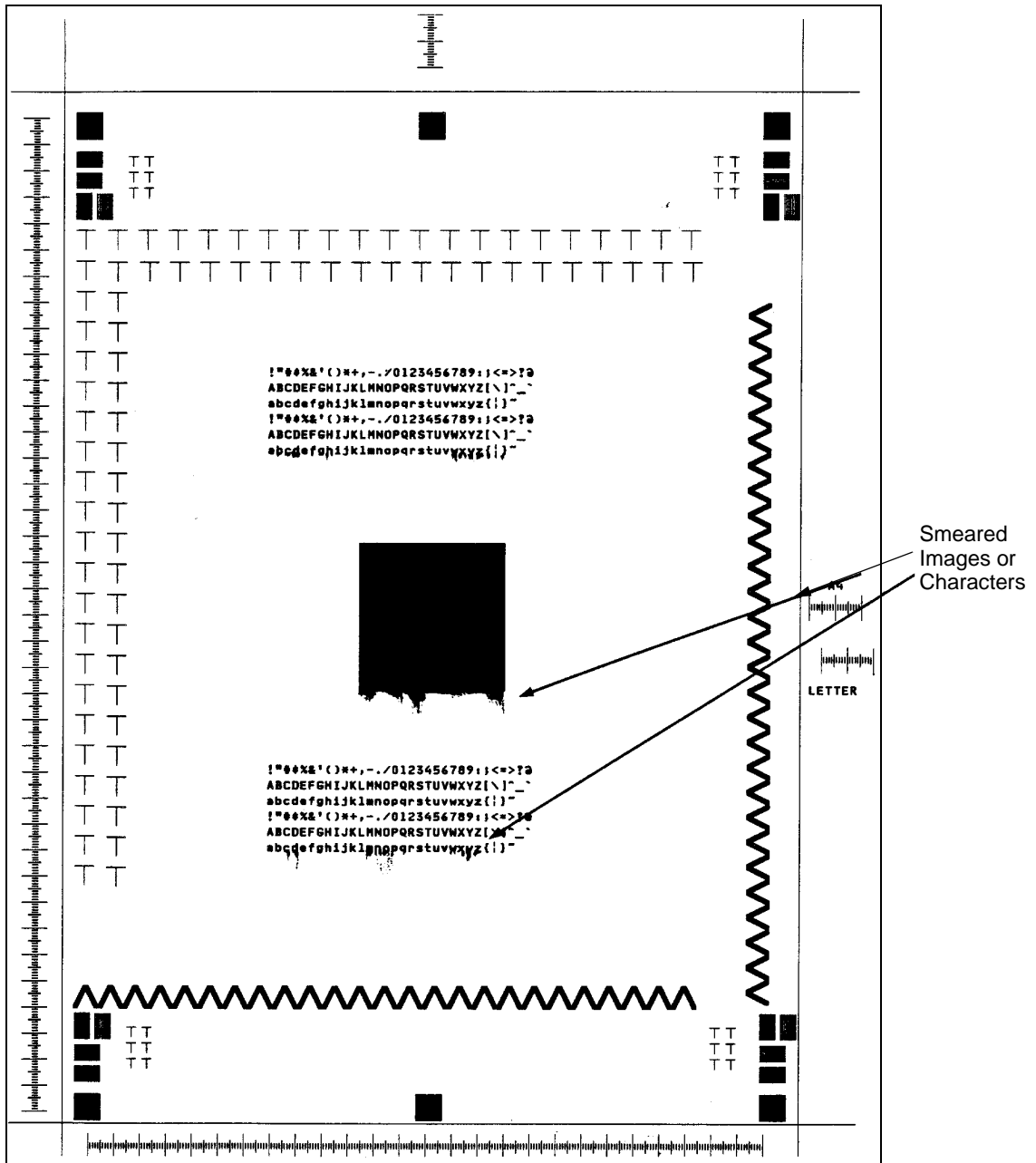

Description: The images or characters are not clear. The lower edges of images and/or characters are extended and may appear smeared.

Go to TAG 809.

Sample 17: Varying Print Density

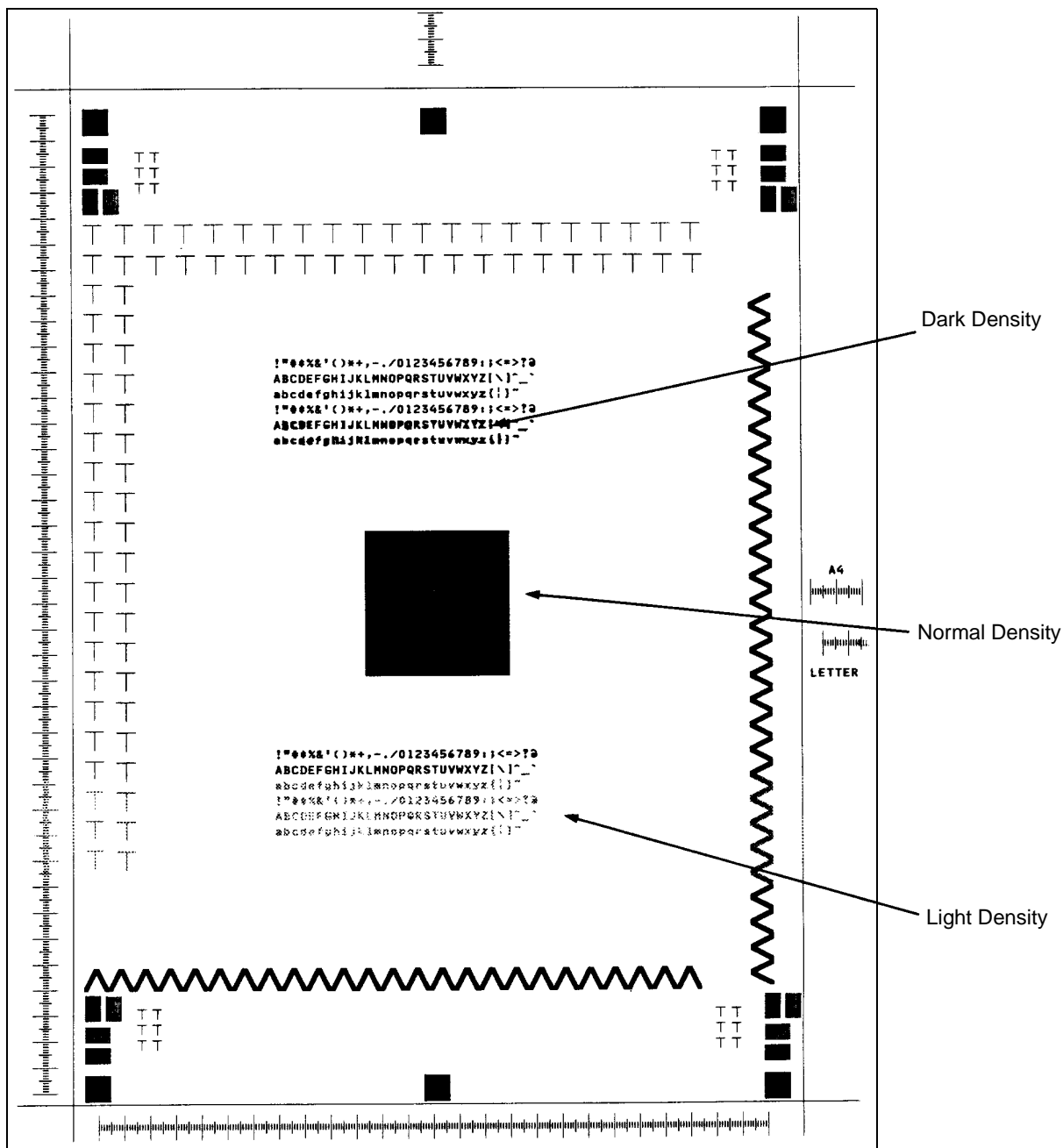

Description: Some areas of the print are lighter or darker than normal. Examine the letters H, T, M, and E on your test print. If the vertical sections are sufficiently dark, but the diagonal sections appear stair-stepped, the problem may be related to the printhead.

Go to TAG 810, 815.

Sample 18: Background

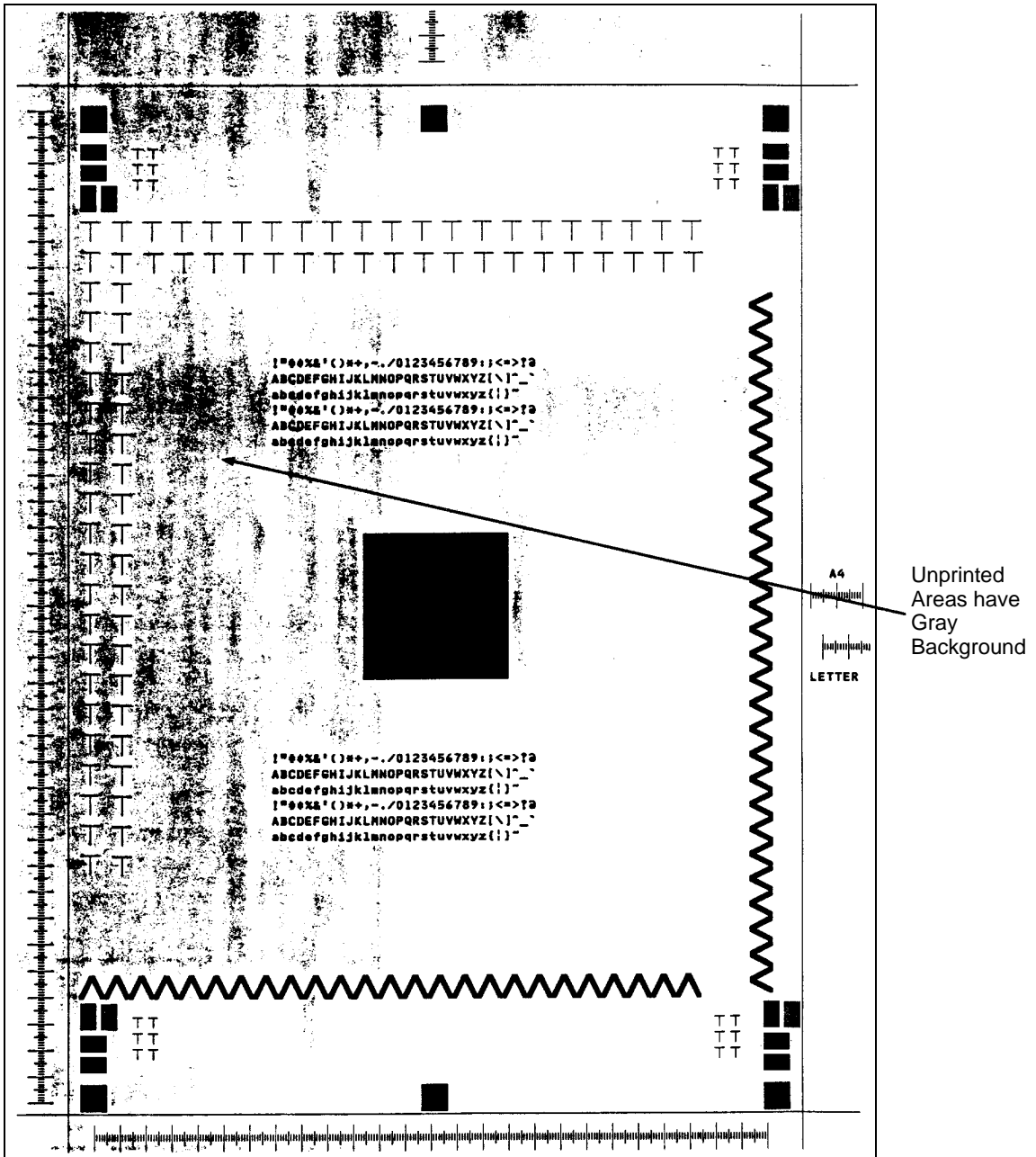

Description: White areas on the prints have varying degrees of specks appearing in a specific pattern.

Go to TAG 811.

Sample 19: Residual Images

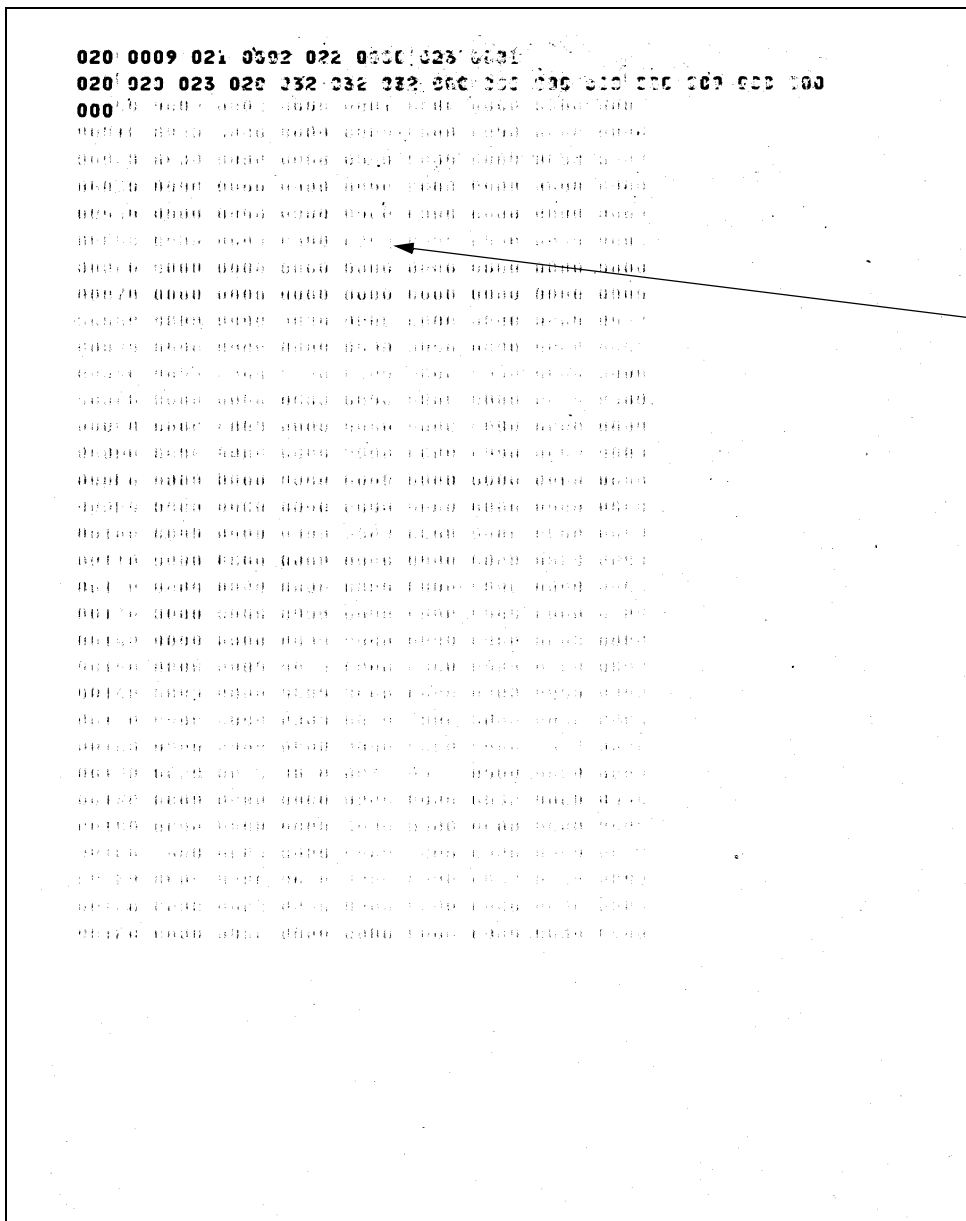

Residual Images
from Previous
Print

Description: Images from a previous print are visible. White areas on the print may have varying degrees of specks appearing in a specific pattern.

Go to TAG 811, 813.

Sample 20: Wrinkles

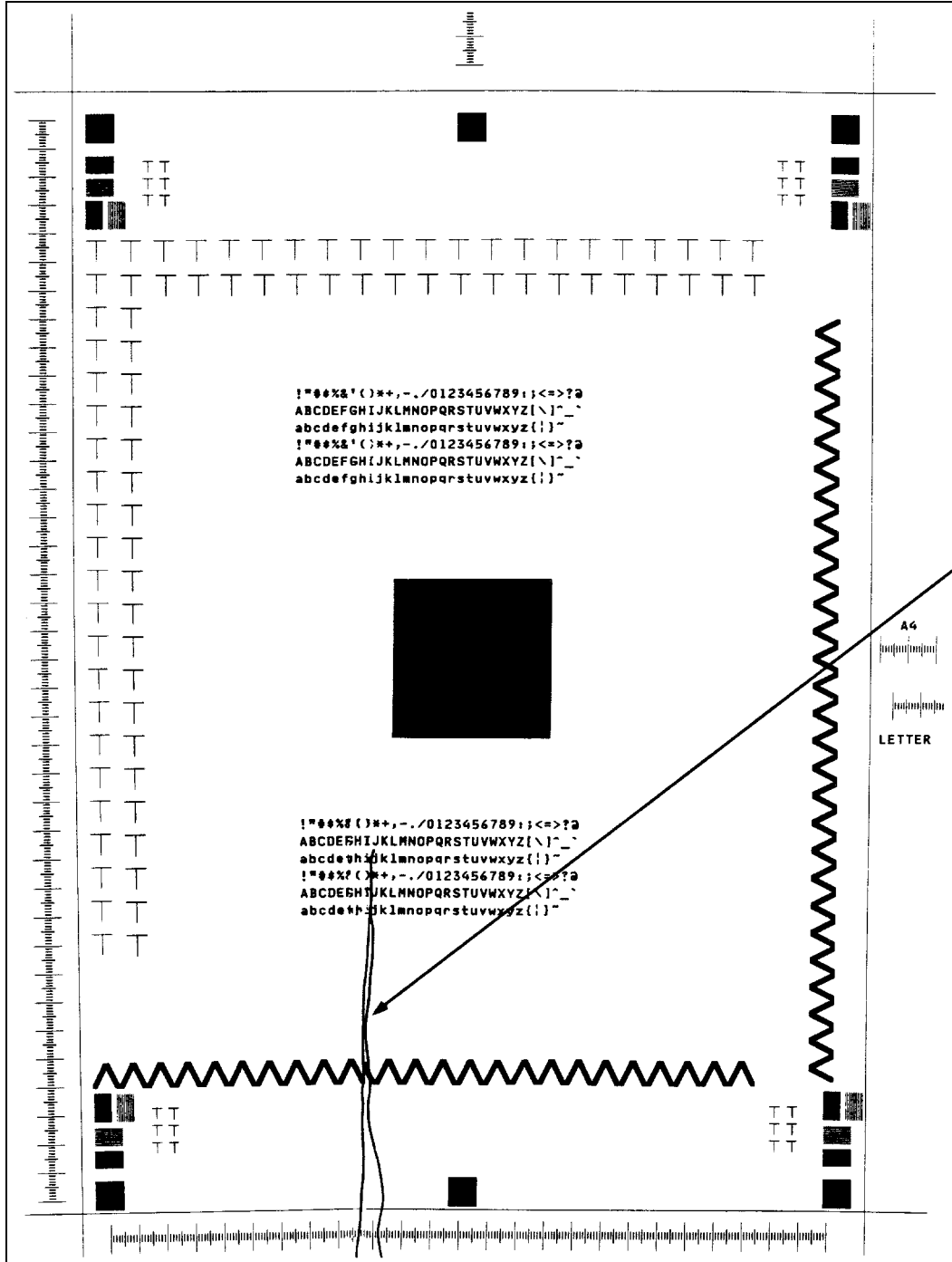

Wrinkled Paper

Description: Wrinkles or creases, often at the top or bottom.

Go to TAG 706.

Sample 21: Fusing Problems

Sample 21: Fusing Problems

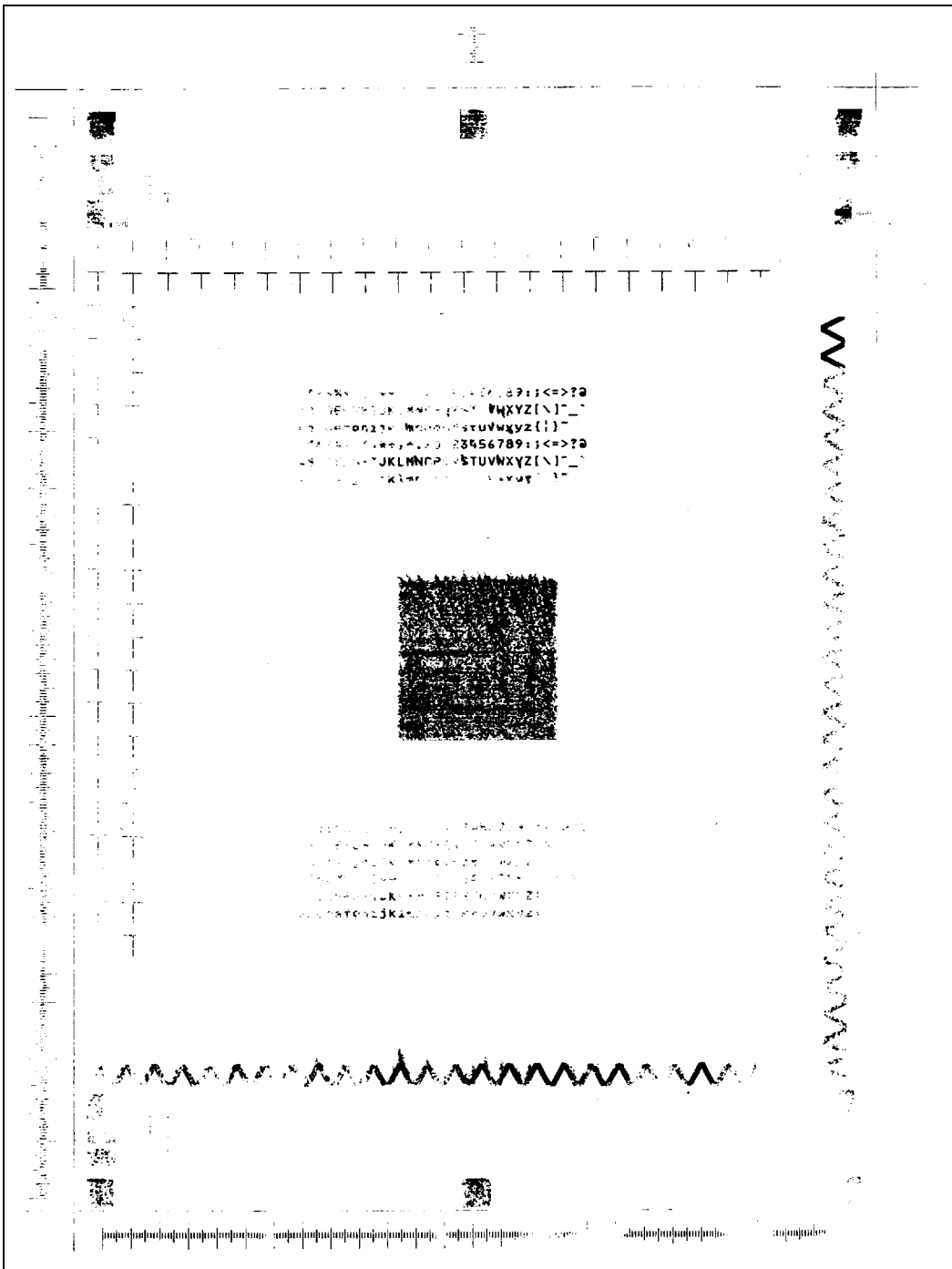

Description: Images or characters may rub off the surface.

Go to TAG 812.

Section 5

***Diagnostic
Tests***

Contents

Diagnostic Tests

| | |
|---|------|
| How to Run Diagnostics | 5-3 |
| Operator Panel Test | 5-4 |
| Upper Cassette Test | 5-4 |
| Lower Cassette Test | 5-5 |
| Fuser Thermistor Test | 5-5 |
| Sensor Tests | 5-6 |
| Roller Clutch Tests | 5-7 |
| Counter Test | 5-7 |
| Jogging Motor Test | 5-8 |
| Photoconductor Seam Sensor Test | 5-8 |
| Toner Supply Motor Test | 5-8 |
| Charge Corona Test | 5-9 |
| Transfer Corona Test | 5-9 |
| Erase Lamp Test | 5-10 |
| Toner Empty Test | 5-10 |
| Negative Developer Bias Test | 5-11 |
| Duplex Motor Tests | 5-11 |
| Duplex Sensor Tests | 5-12 |
| Duplex Clutch Tests | 5-13 |
| Duplex Tray Paper-Guide Motor Test | 5-13 |
| High-Capacity Output (HCO) Sensor Tests | 5-14 |
| High-Capacity Input (HCI) Test | 5-14 |
| LED Printhead Test | 5-15 |
| RIGS Board Test | 5-16 |
| Com. Wrap Test | 5-16 |
| Display File Version Test | 5-17 |
| Format Disk | 5-17 |
| Clear Error Log | 5-18 |
| Disk Drive Test | 5-18 |

Section 5

Diagnostic Tests

This section provides step-by-step instructions for running each of the diagnostic tests available. Check the contents page to find the page on which a specific test is described.

Note that some tests assume the condition set up in a previous test – for example, the “Toner Empty Test” assumes that the developer was removed in the previous “Erase Lamp” test. For this reason, perform the necessary tests in the sequence indicated.

How to Run Diagnostics

Follow these steps to access the self-diagnostic mode of the printer:

- 1 Turn off the printer and wait five seconds.
 - 2 Hold down **MENU** and **STATUS** while turning the printer on until all three LEDs are lit. The printer takes about 1 minute to enter diagnostic mode. When the display reads “Diagnostic Tests” – this is called the *base panel* – you are ready to run tests.
 - 3 Press \triangleright to display the first test. Once a test name is displayed, use these keys:
 - ∇ to move to the next test
 - \triangle to go back to preceding test
 -  **MENU** to return to the base panel
- If you press these keys before a test is complete, a long tone sounds and the test continues without interruption.
- 4 Press \triangleright to run the test.
 - 5 Press \triangleleft to end the test (in most cases; see specific diagnostic procedures for directions on exiting a test).
 - 6 To exit diagnostic mode, cycle printer power.

Most errors or conditions reported are valid until you press a key.

Note: Only diagnostics useful for field maintenance are documented in this manual.

Operator Panel Test

- 1 Turn the volume control on the operator panel up fully.
- 2 At the base panel, press ▷ to enter the “Operator Panel Test.”
- 3 Press ∇ to run the test.
- 4 The panel displays alphanumeric characters. Press ∇ to scroll the characters.
- 5 Press ◀ to exit.

Upper Cassette Test

- 1 Make sure the upper paper cassette is installed with paper, the side and rear guides securely against the edges of the paper in the cassette.
- 2 At the base panel, press ▷ to enter the tests.
- 3 Press ∇ until “Upper Cassette Test” is displayed.
- 4 Press ▷ to run the test.
- 5 The chart below gives the displays that show the paper size in the cassette. This indicates the paper size sensor is working properly.

The following displays indicate paper sizes:

| Display |
|-------------|
| No Cassette |
| Size A4 |
| Size B5 |
| Letter Size |
| Legal Size |
| Executive |

- 6 Press ◀ to exit.

Lower Cassette Test

- 1 Make sure the lower paper cassette is installed with paper, the side and rear guides securely against the edges of the paper in the cassette.
- 2 At the base panel, press ▷ to enter the tests.
- 3 Press ∇ until “Lower Cassette Test” is displayed.
- 4 Press ▷ to run the test.
- 5 The chart below gives the displays that show the paper size in the cassette. This indicates the paper size sensor is working properly.

The following displays indicate paper sizes:

| Display |
|-------------|
| No Cassette |
| Size A4 |
| Size B5 |
| Letter Size |
| Legal Size |
| Executive |

Note: If you have installed the HCI, it should also cause the C40D to display the correct paper setting during testing.

- 6 Press ◀ to exit.

Fuser Thermistor Test

- 1 At the base panel, press ▷ to enter the tests.
- 2 Press ∇ until “Fuser Thermistor Test” is displayed.
- 3 Press ▷ to run the test.
- 4 You will see a response listing the A/D value, such as “A/D Value is nn”
- 5 Press ◀ to exit.

Sensor Tests

Note: Remove the HCO from the printer before running this test.

- 1 At the base panel, press \triangleright to enter the tests.
- 2 Press ∇ until “Sensor Tests” is displayed.
- 3 Press \triangleright to run the test. The name of the first sensor appears on the display, confirming that the sensor is working properly.

Note: No paper moves through the machine, so indications of “Paper Not Hitting” are normal.

- 4 Press \triangleright to advance to the next sensor. The display changes, showing the next sensor as outlined in the chart below.

| 1st Display Line | 2nd Display Line |
|------------------|-------------------------------------|
| Upper Cassette | Not Empty Empty |
| Lower Cassette | Not Empty Empty |
| Paper Timing | Paper Not Hitting Paper Hitting |
| Paper Exit | Paper Not Hitting Paper Hitting |
| Output Tray Full | Not Full Full |
| PC Seam | PSS is Not Active PSS is Active |
| Developer Unit | Developer Connected No Developer |

- 5 To check a specific sensor, press \triangleright repeatedly until the name of the sensor you want to check is displayed. Manually activate the sensor. Confirm that the display changes when you activate the sensor. See [“Sensors and Switches Illustrations”](#) on page 1-8 for the locations of the sensors.
- 6 Press \triangleleft to exit.

Roller Clutch Tests

- 1 At the base panel, press \triangleright to enter the tests.
- 2 Press ∇ until "Roller Clutch Tests" is displayed.
- 3 Press \triangleright to run the test. The first clutch engages and disengages, signaled by a continuous clicking sound. "Upper Paper Pick-up" appears on the display, corresponding to the upper pick-up roller clutch. The display also shows "On" and "Off" alternately as the clutch operates.
- 4 Press ∇ to test the next clutch. The display changes to indicate the next clutch. Listen

| | |
|-------------------|--|
| Output Tray Front | |
| Output Tray Back | |

| | |
|-------------------|--|
| Output Tray Front | |
| Output Tray Back | |

for the clicking sound as the next clutch engages. The displays for each of the clutches are listed in the following chart.

| Display |
|---------------------|
| Upper Paper Pick-up |
| Lower Paper Pick-up |
| Upper Paper Feed |
| Lower Paper Feed |
| Paper Timing Roller |

- 5 Repeat Step 4 until you have tested all of the clutches.
- 6 Press \triangleleft to exit.

Counter Test

- 1 Open the front cover.
- 2 At the base panel, press \triangleright to enter the tests.
- 3 Press ∇ until "Counter Test" is displayed.
- 4 Press \triangleright to run the test.
- 5 Press \triangle to increment the counter.
- 6 Confirm that the page counter advances by 1 each time you press \triangle .
- 7 Press \triangleleft to exit.

Jogging Motor Test

Note: This test exercises the HCO. If you have no HCO attached to the C40D, you will not notice any test activity.

- 1 At the base panel, press ▷ to enter the tests.
- 2 Press ∇ until “Jogging Motor Test” is displayed.
- 3 Press ▷ to run the test.
- 4 The HCO exit rollers jog left and right.
- 5 Press ◀ to exit.

Photoconductor Seam Sensor Test

- 1 At the base panel, press ▷ to enter the tests.
- 2 Press ∇ until “PC Seam Sensor Test” is displayed.
- 3 Press ▷ to run the test. The main motor rotates the photoconductor belt.

Be aware that the following error conditions may occur:

- Developer bias short detected
 - Photoconductor seam sensor not received or detected
 - Seam sensor (sender) short
 - Seam sensor (sender) open or the photoconductor is not installed
 - Erase lamp malfunction
- 4 Press ◀ to exit.

Toner Supply Motor Test

- 1 Open the front and top covers.
- 2 Remove the photoconductor and the developer. Place the photoconductor in its protective packaging.
- 3 Insert the interlock by-pass tool in the front cover. Close the top cover.
- 4 At the base panel, press ▷ to enter the tests.
- 5 Press ∇ until “Toner Motor Test” is displayed.
- 6 Press ▷ to run the test. The toner supply motor runs continuously.
- 7 Observe the toner supply motor through the open developer cavity. Confirm that the motor is turning counterclockwise, accompanied by “On” on the display.

- 8 Press ◀ and ▶ alternately several times to verify the toner supply motor starts and stops. (This stops and restarts the test.)

Be aware that the following error conditions may occur:

- You forgot to remove the developer
 - You forgot to insert the interlock by-pass tool
- 9 Press ◀ to exit.
 - 10 Reinstall the developer and photoconductor.
 - 11 Remove the interlock by-pass tool and close the front cover.

Charge Corona Test

- 1 Remove the photoconductor and place it in its protective packaging. Close the top cover.
- 2 At the base panel, press ▶ to enter the tests.
- 3 Press ▼ until “Main Charger Test” is displayed.
- 4 Press ▶ to run the test. The charge corona turns on and off repeatedly.
- 5 Confirm that the display alternates between “Off” and “On,” accompanied each time by a brief tone.

Be aware that the following error conditions may occur:

- Photoconductor seam sensor short
 - Charge corona short
 - Charge corona open
 - You forgot to remove the photoconductor
- 6 Press ◀ to exit.
 - 7 Reinstall the photoconductor.

Transfer Corona Test

- 1 Remove the photoconductor and place it in its protective packaging. Close the top cover.
- 2 At the base panel, press ▶ to enter the tests.
- 3 Press ▼ until “Transfer Corona Test” is displayed.
- 4 Press ▶ to run the test. The transfer corona turns on and off repeatedly.
- 5 Confirm that the display alternates between “Off” and “On,” accompanied each time by a brief tone.

Erase Lamp Test

Be aware that the following error conditions may occur:

- Seam sensor (sender) short
 - Transfer corona short
 - Transfer corona open or not installed
 - You forgot to remove the photoconductor
- 6 Press ◀ to exit.
 - 7 Reinstall the photoconductor.

Erase Lamp Test

- 1 Open the top cover and insert the interlock by-pass tool.
- 2 Remove the photoconductor and place it in its protective cover.
- 3 At the base panel, press ▶ to enter the tests.
- 4 Press ▼ until “Erase Lamp Test” is displayed.
- 5 Press ▶ to run the test. The erase lamp turns on with all LEDs lighted.
- 6 Verify that all LEDs are illuminated.

Be aware that the following error conditions may occur:

- Seam sensor (sender) short
 - Erase lamp malfunction
 - You forgot to remove the photoconductor
- 7 Press ◀ to exit.
 - 8 Reinstall the photoconductor.
 - 9 Remove the interlock by-pass tool and close the top cover.

Toner Empty Test

- 1 At the base panel, press ▶ to enter the tests.
- 2 Press ▼ until “Toner Empty Test” is displayed.
- 3 Press ▶ to run the test. Verify that the Toner Empty message appears on the display.
- 4 If the developer is not in the C40D, you will get a “No Developer” message.
- 5 Press ◀ to exit.

Negative Developer Bias Test

- 1 Open the top cover and insert the interlock by-pass tool.
- 2 Remove the photoconductor and place it in its protective packaging.
- 3 At the base panel, press ▷ to enter the tests.
- 4 Press ∇ until “Neg Devel Bias Test” is displayed.
- 5 Press ▷ to run the test. The negative developer bias turns on and off repeatedly.
- 6 Confirm that the display alternates between “Off” and “On,” accompanied each time by a brief tone.

Be aware that the following error conditions may occur:

- Developer bias short
 - Seam sensor (sender) short
 - You forgot to insert the interlock by-pass tool
 - You forgot to remove the photoconductor
- 7 Press ◁ to exit.
 - 8 Reinstall the photoconductor.
 - 9 Remove the interlock by-pass tool and close the top cover.

Duplex Motor Tests

- 1 At the base panel, press ▷ to enter the tests.
- 2 Press ∇ until “Duplex Motor Tests” is displayed.
- 3 Press ▷ to run the test. The duplex feed motor operates at full forward speed as indicated on the display.
- 4 Press ∇ to advance to the next motor speed.
- 5 Listen for the following motor frequencies and check the display as you move through the test sequence:

| Display |
|--------------------|
| Forward Full Speed |
| Forward Slow Speed |
| Reverse Full Speed |
| Reverse Slow Speed |

Note: To view the timing roller while running the test, open the printer top cover and bypass the cover interlock.

Duplex Sensor Tests

Be aware that the following error conditions may occur:

- Duplex is not installed
 - Cover is open/Close cover
- 6 Press ◀ to exit.
 - 7 Remove the cover interlock bypass.

Duplex Sensor Tests

- 1 At the base panel, press ▶ to enter the tests.
- 2 Press ▼ until “Duplex Sensor Tests” is displayed.
- 3 Press ▶ to run the test. The name of the first sensor appears on the display, confirming that the sensor is working properly.

Note: No paper moves through the machine, so indications of “Paper Not Hitting” are normal.

- 4 Press ▼ to advance to the next sensor. The display changes, showing the name of the next sensor as outlined in the chart below.

| 1st Display Line | 2nd Display Line |
|--------------------|------------------------------------|
| B-C Paper Sensor | Paper Not Hitting Paper Hitting |
| Duplexer Cover | Cover is Closed Cover is Open |
| Duplex Tray Sensor | Paper Not Hitting Paper Hitting |

- 5 To check a specific sensor, press ▼ repeatedly until the sensor you want to check is displayed, then manually activate the sensor. Confirm that the display changes when you activate the sensor. See [“Sensors and Switches Illustrations”](#) on page 1-8 for the locations of the sensors.

Be aware that the following error conditions may occur:

- Duplex tray is not installed
 - Cover is open/Close cover
- 6 Press ◀ to exit.

Duplex Clutch Tests

- 1 At the base panel, press \triangleright to enter the tests.
- 2 Press ∇ until “Duplex Clutch Tests” is displayed.
- 3 Press \triangleright to run the test. The first flipper engages, accompanied by a continuous clicking sound, “Exit Flipper” appears on the display, and the display shows “On” or “Off”, according to the flipper’s state.
- 4 Press ∇ to activate the next clutch or flipper. Listen for the clicking sound as it engages. The display changes to indicate the next clutch or flipper.

| Display |
|------------------|
| Exit Flipper |
| A-roller Clutch |
| Re-entry Flipper |
| C-roller |

- 5 To check a specific clutch or flipper, press ∇ repeatedly until the code on the display corresponds to the item you want to check. Manually activate the sensor. Confirm that the display changes when you activate the sensor. See [“Sensors and Switches Illustrations” on page 1-8](#) for the locations of the sensors.

Be aware that the following error conditions may occur:

- Duplex tray is not installed
 - Cover is open/Close cover
- 6 Press \triangleleft to exit.

Duplex Tray Paper-Guide Motor Test

- 1 At the base panel, press \triangleright to enter the tests.
- 2 Press ∇ until “Duplex Paper Guide” is displayed.
- 3 Press \triangleright to run the test. The paper guide in the duplex tray moves to and from its home position.
- 4 Confirm that the paper guide in the duplex tray moves back and forth constantly.

Be aware that the following error conditions may occur:

- Duplex tray not installed
 - Duplex tray registration sensor not activated
 - Duplex tray registration sensor activated
 - Cover is open/Close cover
- 5 Press \triangleleft to exit.

High-Capacity Output (HCO) Sensor Tests

- 1 At the base panel, press \triangleright to enter the tests.
- 2 Press ∇ until “Hi Cap Output Sensor” is displayed.
- 3 Press \triangleright to run the test. The code for the sensor appears on the display, confirming that the sensor is working properly.

Note: No paper moves through the machine, so indications of “Paper Not Hitting” are normal.

- 4 Press ∇ to advance to the next sensor. The sensor appears on the display; codes and their meaning are outlined in the chart below.

| 1st Display Line | 2nd Display Line |
|-------------------|--|
| HCO Unit Sensor | Not Installed Output Installed |
| Paper Exit Sensor | Paper Not Hitting paper Hitting |
| Paper Full Sensor | Output Tray Not Full Output Tray Full |
| Tray Wait Sensor | Tray Ready Tray Rising |

- 5 To check a specific sensor, press ∇ repeatedly until the sensor you want to check is displayed. Manually activate the sensor. Confirm that the display changes when you activate the sensor. See “[Sensors and Switches Illustrations](#)” on page 1-8 for the locations of the sensors.
- 6 Press \triangleleft to exit.

High-Capacity Input (HCI) Test

- 1 At the base panel, press \triangleright to enter the tests.
- 2 Press ∇ until “Hi Cap Input Size” is displayed.
- 3 Press \triangleright to run the test. The display registers the paper size installed in the unit, as outlined on the chart (“No Cassette” will appear on the display if a high-capacity input is not installed.)

- 4 Verify the correct paper size, as displayed.

| Display |
|-------------|
| No Cassette |
| Size A4 |
| Letter Size |
| Legal Size |

- 5 Press ◀ to exit.

LED Printhead Test

- 1 Open the top cover and insert the interlock by-pass tool.
- 2 Remove the photoconductor and place it in its protective packaging.
- 3 Remove the developer.
- 4 To help identify the LEDs, place a white sheet of paper in the photoconductor cavity over the printhead's fiber optics.
- 5 At the base panel, press ▶ to enter the tests.
- 6 Press ▼ until "LED Printhead Test" is displayed.
- 7 Press ▶ to run the test.
- 8 The LED printhead turns on.
- 9 Verify that the LEDs cycle on and off.

These codes indicate specific error conditions:

| Display | Indication |
|---------|---|
| 4-1 | You forgot to remove the photoconductor unit. |
| 040 | Seam sensor (sender) short |

- 10 Press ◀ to exit.

RIGS Board Test

- 1 At the base panel, press ▷ to enter the tests.
- 2 Press ▽ until “RIGS Board Test” is displayed.
- 3 Press ▷ to run the test.
- 4 If an error is found:
 - The error message and code appear.
 - Look up the code in the [“Error Code/TAG Cross-Reference” on page 2-4](#) to determine which TAG to follow.
 - Press ◀ to exit.
- 5 If no errors are found, the message “Test Successful” is displayed.
- 6 Press ◀ to exit.

Com. Wrap Test

Note: You can run this test successfully without the C40D being configured for RS-232 operation.

- 1 Remove the interface cable from the printer.
- 2 Install the RS-232C wrap connector, found in the tool kit mounted inside the right printer cover.

If you do not have wrap connectors, jumper the connections as outlined in the following charts:

| RS-232 Loopback Connection Reference | | |
|--------------------------------------|---------|--------|
| pin 2 | <-----> | pin 3 |
| pin 4 | <-----> | pin 5 |
| pin 8 | <-----> | pin 20 |
| pin 17 | <-----> | pin 24 |

- 3 At the base panel, press ▷ to enter the tests.
- 4 Press ▽ until “Com. Wrap Test” is displayed.
- 5 Press ▷ to select the test.
- 6 Press ▷ to run the test.
- 7 If an error code appears, check the [“Error Code/TAG Cross-Reference” on page 2-4](#) to determine which TAG to follow.
- 8 If no error is detected, the test exits automatically.

- 9 Press ◀ to exit, if an error is detected. (For some errors, you may have to power-on-reset the printer.)
 - 10 Remove the wrap connectors.
 - 11 Reinstall the interface cable.
-

Display File Version Test

- 1 At the base panel, press ▷ to enter the tests.
 - 2 Press ▽ or △ until the desired drive shows on the display.
 - 3 Press ▷ to select the drive.
 - 4 Press ▽ or △ to find the file to test.
 - 5 Press ▷ to run the test. You will see “Version Number = nnnn”, where *nnnn* is the function code version number.
 - 6 Press ◀ to exit.
-

Format Disk

- 1 At the base panel, press ▷ to enter the tests.
- 2 Press ▽ until “Format Disk” shows on the display.
- 3 Press ▷ to select this function.
- 4 Press ▽ to “Format Hard Drive C” and press ▷ to select this drive.
- 5 You will see “Status = Erase Disk”. Press the **Status** key to format drive C.
- 6 Press ◀ to exit.

Note: When using the **FORMAT DISK** function of the self-diagnostic mode, **any existing data on the specified disk is at risk!**

Note: If you access this function by mistake, do not proceed. Press ◀ immediately to exit the utility.

Clear Error Log

- 1 At the base panel, press ▷ to enter the tests.
- 2 Press ∇ until “Clear Error Log” shows on the display.
- 3 Press ▷ to run the test.
- 4 Press ∇ to advance to the drive where the error log is maintained. This is usually the boot drive.
- 5 Press ▷ to clear the error log on the selected drive.
- 6 Press ◀ to exit.
- 7 Confirm that the error log has been cleared.
- 8 Exit diagnostic mode (power-on reset)
- 9 Print the error log. All errors in all sections should be reset to zero.

Disk Drive Test

Note: This is a non-destructive test. You can use it to test drive A, the 3.25” floppy disk drive (if you have inserted a C40D formatted diskette in it), or drive C, the hard drive.

- 1 At the base panel, press ▷ to enter the tests.
- 2 Press ∇ until “Disk Drive Test” is displayed.
- 3 Press ▷ to run the test.
- 4 Press ∇ to change the drive parameter.
- 5 Press ▷ to test the selected drive.
- 6 Press ◀ to exit.

Wiring Diagrams and Electrical Data

Contents

Wiring Diagrams and Electrical Data

| | |
|---|------|
| Introduction | 6-3 |
| Printhead Circuit Board Settings | 6-3 |
| Connector (J/P) Index | 6-4 |
| Acronyms and Abbreviations | 6-9 |
| Connectors Inside the Front Cover | 6-12 |
| Connectors Inside the Left Cover | 6-13 |
| Connectors on the Duplex Cover | 6-14 |
| Connectors Inside the Right Cover | 6-15 |
| Connectors Inside the Top Cover | 6-16 |
| Connectors on the Back Cover | 6-17 |
| Connectors Inside the Back Cover (J/P2-14) | 6-18 |
| Connectors Inside the Back Cover (Continued) J/P 18-62 | 6-19 |
| Connectors Inside the Back Cover (Continued) J/P 64-85 | 6-20 |
| Connectors Inside the Back Cover (Continued) J/P 90-800 | 6-21 |
| Voltage Isolation Diagrams | 6-22 |
| -12 Vdc Circuits | 6-22 |
| +5 Vdc Circuits | 6-22 |
| +12 Vdc Circuits | 6-24 |
| +24 Vdc Circuits | 6-26 |
| Ground System | 6-27 |
| Host Interface Reference | 6-28 |
| RS-232C Host Interface | 6-28 |
| Standard DCE to DTE RS-232C Cable | 6-29 |
| Special Considerations for RS-232 Host Interface Users | 6-29 |
| DTE Host to Printer (Option 1) | 6-29 |
| DTE Host to Printer (Option 2) | 6-30 |
| IBM PC/XT to Printer | 6-30 |
| IBM PC/AT to Printer | 6-31 |
| Macintosh Communication Port to Printer | 6-31 |
| Centronics Parallel Host Interface | 6-32 |
| IBM Parallel to Printer | 6-33 |

Section 6

Wiring Diagrams and Electrical Data

Introduction

This section provides a reference guide for all information related to the electrical system of the printer, including:

- An index, arranged by connector number, to the connector's location in the printer and on the schematics, which are found in this chapter.

Note: Connectors are referred to by J/P (jack/plug) numbers throughout this manual. Use the J/P number when looking up the connector in the index, schematics, and illustrations.

- Complete connection diagram showing plugs, connectors, and wiring.
- Connector locations and illustrations.
- Voltage isolation diagrams.
- Host interface signal definitions.

For a complete list of the abbreviations used in this section, please see page 6-9.

Printhead Circuit Board Settings

Note: The printhead circuit board uses DIP switches to match printhead characteristics to controller characteristics. Do not change these DIP switch settings; they should remain as set at the factory.

Connector (J/P) Index

| Connector | Page | Schematic Location |
|-----------|------------|--------------------|
| J/P 2 | 6-18 | F4 |
| J/P 3 | 6-18 | F4 |
| J/P 4 | 6-18 | E6 |
| J/P 5 | 6-16 | E5 |
| J/P 6 | 6-18 | E7 |
| J/P 7 | 6-18 | D8 |
| J/P 8 | 6-18 | D7 |
| J/P 9 | 6-18 | C4 |
| J/P 10 | 6-18 | C4 |
| J/P 11 | 6-18 | B4 |
| J/P 12 | 6-18 | B4 |
| J/P 13 | 6-18 | B3 |
| J/P 14 | 6-18 | C3 |
| J/P 15 | 6-15 | D11 |
| J/P 18 | 6-19 | B3 |
| J/P 20 | 6-19 | C3 |
| J/P 21 | 6-19 | B3 |
| J/P 22 | 6-15, 6-19 | C3 |
| J/P 22-1 | 6-14 | C2 |
| J/P 23 | 6-19 | B7 |
| J/P 25 | 6-19 | C4 |
| J/P 26 | 6-19 | B6 |
| J/P 27 | 6-19 | C6 |
| J/P 30 | 6-19 | C6 |
| J/P 31 | 6-16 | B8 |
| J/P 32 | 6-16 | B8 |
| J/P 33 | 6-16 | B8 |
| J/P 34 | 6-16 | B8 |
| J/P 36 | 6-16 | C8 |

| Connector | Page | Schematic Location |
|-----------|------|--------------------|
| J/P 37 | 6-16 | C8 |
| J/P 40 | 6-16 | C8 |
| J/P 41 | 6-16 | C8 |
| J/P 42 | 6-12 | B9 |
| J/P 43 | 6-13 | D10 |
| J/P 44 | 6-19 | E5 |
| J/P 45 | 6-13 | C10 |
| J/P 46 | 6-13 | D9 |
| J/P 47 | 6-13 | D10 |
| J/P 48 | 6-13 | D9 |
| J/P 49 | 6-15 | E9 |
| J/P 50 | 6-19 | E9 |
| J/P 51 | 6-15 | E9 |
| J/P 57 | 6-16 | E9 |
| J/P 58 | 6-19 | E9 |
| J/P 59 | 6-13 | E9 |
| J/P 60 | 6-19 | E9 |
| J/P 61 | 6-13 | E10 |
| J/P 62 | 6-19 | E10 |
| J/P 63 | 6-16 | C5 |
| J/P 64 | 6-20 | C5 |
| J/P 65 | 6-20 | F8 |
| J/P 66 | 6-20 | F9 |
| J/P 67 | 6-20 | F9 |
| J/P 68 | 6-20 | F9 |
| J/P 69 | 6-20 | F10 |
| J/P 70 | 6-20 | E4 |
| J/P 76 | 6-16 | B8 |
| J/P 77 | 6-20 | D6 |
| J/P 79 | 6-20 | C6 |

Connector (J/P) Index

| Connector | Page | Schematic Location |
|-----------|------|--------------------|
| J/P 81 | 6-20 | A5 |
| J/P 82 | 6-12 | A4 |
| J/P 83 | 6-20 | E5 |
| J/P 84 | 6-20 | E6 |
| J/P 85 | 6-20 | B6 |
| J/P 90 | 6-21 | C9 |
| J/P 91 | 6-16 | C8 |
| J/P 94 | 6-21 | C8 |
| J/P 96 | 6-21 | C5 |
| J/P 119 | 6-13 | C9 |
| J/P 120 | 6-13 | C9 |
| J/P 121 | 6-21 | B6 |
| J/P 122 | 6-21 | B6 |
| J/P 124 | 6-21 | B6 |
| J/P 127 | 6-13 | C9 |
| J/P 128 | 6-13 | C9 |
| J/P 131 | 6-16 | E6 |
| J/P 132 | 6-16 | E6 |
| J/P 139 | 6-21 | B6 |
| J/P 140 | 6-21 | B6 |
| J/P 143 | 6-21 | B6 |
| J/P 251 | 6-21 | B5 |
| J/P 252 | 6-21 | B5 |
| J/P 255 | 6-21 | A5 |
| J/P 305 | 6-16 | E3 |
| J/P 306 | 6-14 | E2 |
| J/P 307 | 6-14 | E3 |
| J/P 308 | 6-14 | E2 |
| J/P 309 | 6-14 | E2 |
| J/P 310 | 6-16 | F3 |

| Connector | Page | Schematic Location |
|-----------|------|--------------------|
| J/P 311 | 6-16 | F3 |
| J/P 312 | 6-16 | F3 |
| J/P 313 | 6-14 | F2 |
| J/P 314 | 6-14 | E2 |
| J/P 315 | 6-14 | E2 |
| J/P 316 | 6-14 | E2 |
| J/P 317 | 6-15 | D2 |
| J/P 318 | 6-12 | F1 |
| J/P 319 | 6-14 | E2 |
| J/P 320 | 6-16 | G2 |
| J/P 321 | 6-16 | G2 |
| J/P 322 | 6-16 | F2 |
| J/P 323 | 6-21 | D3 |
| J/P 324 | 6-21 | E3 |
| J/P 330 | 6-21 | E8 |
| J/P 331 | 6-21 | D3 |
| J/P 333 | 6-21 | A8, D2 |
| J/P400 | 6-14 | B9 |
| J/P 600 | 6-16 | C8 |
| J/P 800 | 6-21 | E5 |

This space left intentionally blank.

This page indexed as the C40D schematic on page 6-7. Page 6-8 will be blank and the next regular page is 6-9.

Connector (J/P) Index

Acronyms and Abbreviations

ACIA..... Asynchronous Communication Interface Adapter
 ALU Arithmetic Logic Unit
 APA..... All Points Addressable
 ARC “A” Roller Clutch
 ARIF Array Interface
 ATC..... Auto Toner Control
 CLEANER..... Cleaner Unit
 CNT Counter
 COOLING FA2..... Cooling Fan
 COS..... Cover Open Sensor
 CRS “C” Roller Solenoid
 CRT Cathode Ray Tube
 CRTC CRT Controller
 CRU Customer-Replaceable Unit
 DB-..... Developer Bias Negative
 DB+..... Developer Bias Positive
 DC P.S.1 DC Power Supply
 DEV Developer Unit
 DMAC Direct Memory Access Controller
 DMC Dynamic Memory Controller
 DRAM Dynamic Random Access Memory
 DUPLEX1 Duplex Control #1
 DUPLEX2..... Duplex Control #2
 EL..... Eraser LED
 EPROM..... Erasable Programmable Read Only Memory
 EPP..... Electrophotographic Process
 EPS..... Exit Paper Sensor
 ERASER Erase Lamp
 EXS Exit Solenoid
 FA4..... Cooling Fan
 FDC..... Floppy Disk Controller
 FDD Floppy Disk Drive
 FL..... Fuser Halogen Lamp
 Flex IO Flex Input/Output card
 FRU..... Field-Replaceable Unit

FUSERFuser Unit
 HCI.....High Capacity Input
 HCOHigh Capacity Output
 HEAD.....LED Array Print Head
 HDDHard Disk Drive
 HVUHigh Voltage Unit
 IGSImage Generation System
 I.L. SW FrontInterlocking Switch (Front)
 I.L. SW Top.....Interlocking Switch (Top)
 INSIn Solenoid
 IPL.....Initial Program Load (Bootstrap)
 L PAPSLower Paper Sensor
 LN03DEC emulation language
 LPCLower Paper Feed Clutch
 LPE.....Lower Paper Empty Sensor
 LPPLower Pick Up Clutch
 LPSS.....Lower Tray Interlock Switch
 MainMain Motor
 MAPMaintenance Analysis Procedures
 MCH.....Charge Corona Unit
 MCSCharge Corona Sensor
 MPUMicro Processing Unit
 MUXMultiplexer
 OPCOrganic Photoconductor
 OPPNLOperator Panel
 PC.....Photoconductor
 PCL 1. Hewlett-Packard Printer Control Language (Software)
 2. Printer Control Logic Board (Hardware)
 PCL5HP Printer Control Language (Version 5)
 PCUPhotoconductor Unit
 PFSPaper Full Sensor
 PH 1A.C. Power Cord
 PIAPeripheral Interface Adapter
 PITParallel Interface/Timer

Acronyms and Abbreviations (continued)

| | | | |
|---------------------|---------------------------------------|---------------|---|
| PMP | Page Map Primitives | TES | Toner Empty Sensor |
| POR | Power On Reset | TFS | Tray Front Sensor |
| PPS | Paper Path Sensor (B-C Sensor) | TH..... | Thermistor |
| PROM | Programmable Read Only Memory | TONER..... | Toner Motor |
| PS | PostScript | TPS | 1. Timing Paper Sensor (Schematics) 2. Toner Patch Sensor (Printer) |
| PSS | Photoconductor Seam Sensor | TRC | Timing Roller Clutch |
| PTM..... | Programmable Timer Module | TRS..... | Tray Rear Sensor |
| PTS | Paper Timing Sensor | U PAPS | Upper Paper Sensor |
| PW CONT2..... | Power Control #2 | UMT 1–3 | Usage Meter Drive Signal |
| PW CONT3..... | Power Control #3 | UPC | Upper Paper Feed Clutch |
| PWBA | Printed Wire Board Assembly | UPE | Upper Paper Empty Sensor |
| RAM..... | Random Access Memory | UPP..... | Upper Pick Up Clutch |
| Resist Motor | Registration Motor | UPSS | Upper Tray Interlock |
| RIGS..... | RISC Image Generation System | VPCL..... | Video Printer Control Logic Board |
| ROM..... | Read Only Memory | | |
| Root Motor | “C” Roller Motor | | |
| RPS..... | Registration Paper Sensor | | |
| RSS..... | Registration Side Sensor | | |
| SCC | Serial Communication Controller | | |
| SIG IF or SIF | Signal Interface Board | | |
| SRAM | Static Random Access Memory | | |
| SRC | System Reference Code | | |
| SRMR2..... | Side Registration Motor Control #2 | | |
| Suction FA3..... | Suction Fan | | |
| SW5..... | Upper Cassette In Switch | | |
| SW6..... | Lower Cassette In Switch | | |
| TAGs | Troubleshooting Analysis Guides | | |
| TC..... | Toner Concentration | | |
| TCH..... | Transfer Corona Unit | | |
| TCS | Transfer Corona Sensor | | |
| TDS | Toner Density Sensor | | |

Connector Locations

The illustrations that follow show the relative location of all accessible connectors in the printer, and illustrate the connector (except for a few instances in which the connector is so simple that an illustration is unnecessary). For the connector's schematic location, refer to the chart on the preceding pages.

Connectors Inside the Front Cover

Connectors Inside the Front Cover

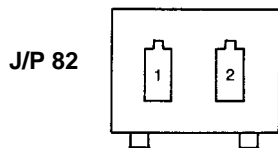
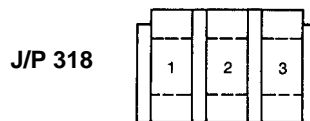
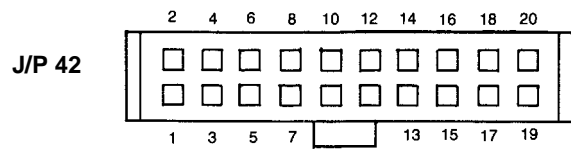
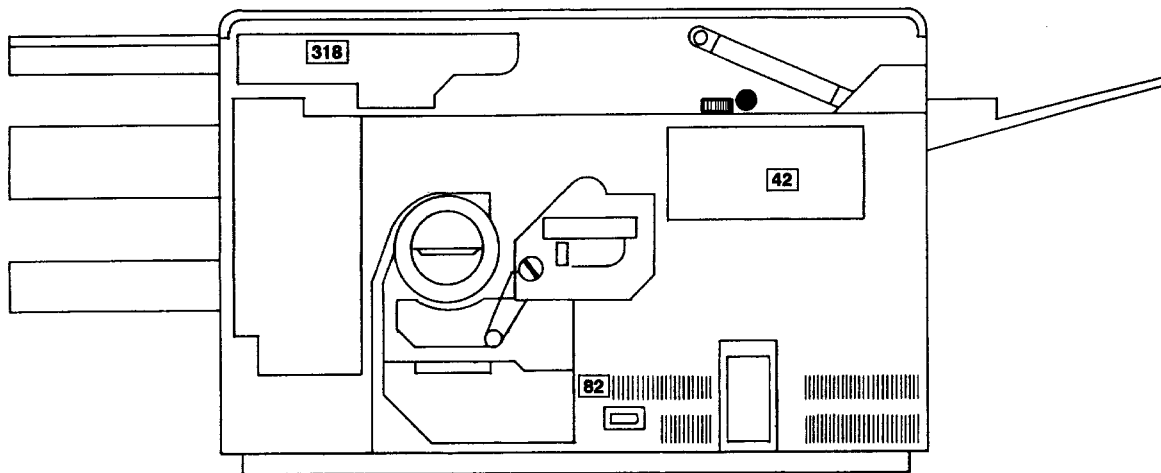

Connectors Inside the Left Cover

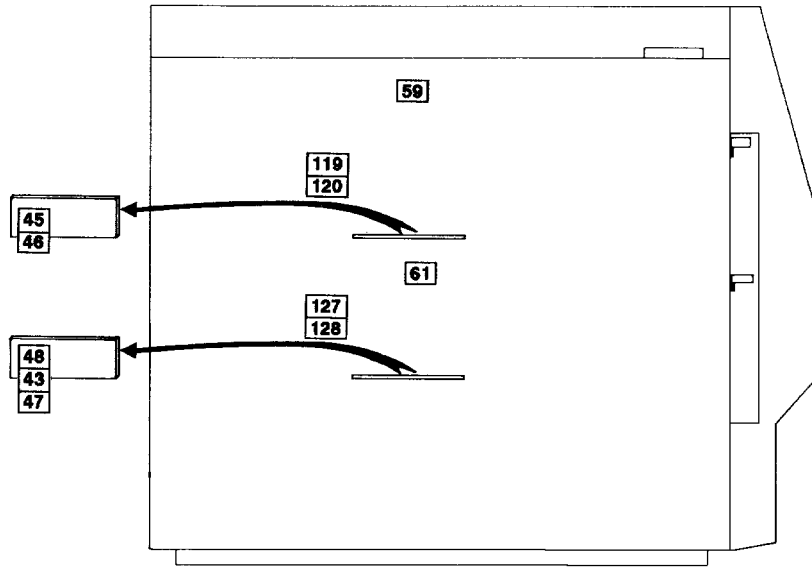

J/P 43,45, 47



J/P 59, 61

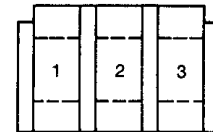

J/P 46, 48

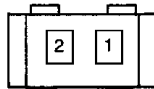

J/P 119, 120, 127, 128

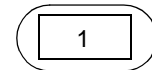

Connectors on the Duplex Cover

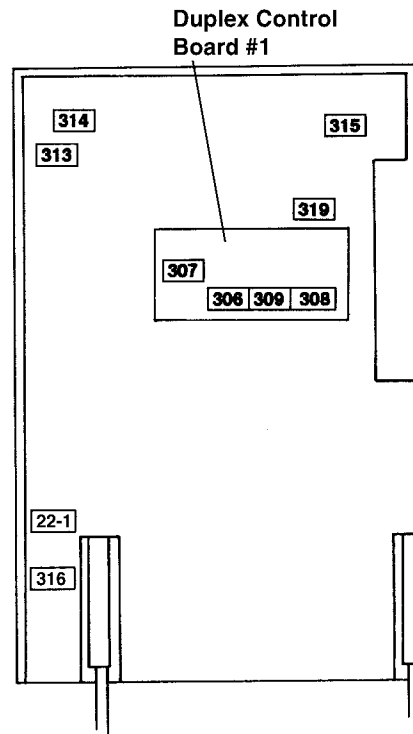

J/P 22-1

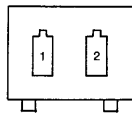

J/P 314

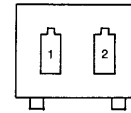

J/P 306

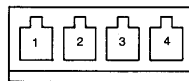

J/P 315

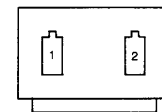

J/P 307

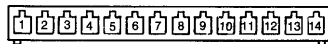

J/P 316

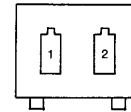

J/P 308

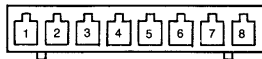

J/P 319

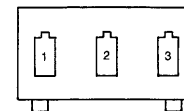

J/P 309

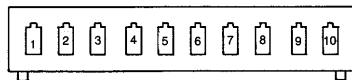

J/P 313

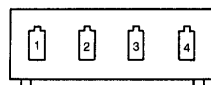

Connectors Inside the Right Cover

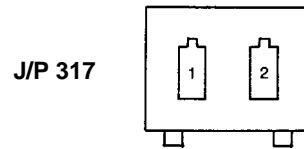
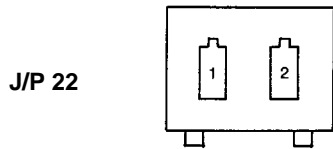
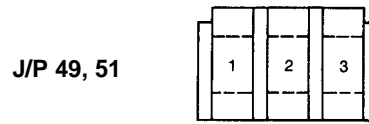
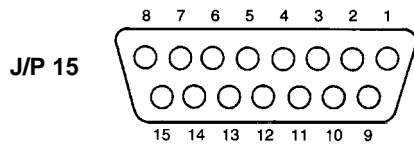
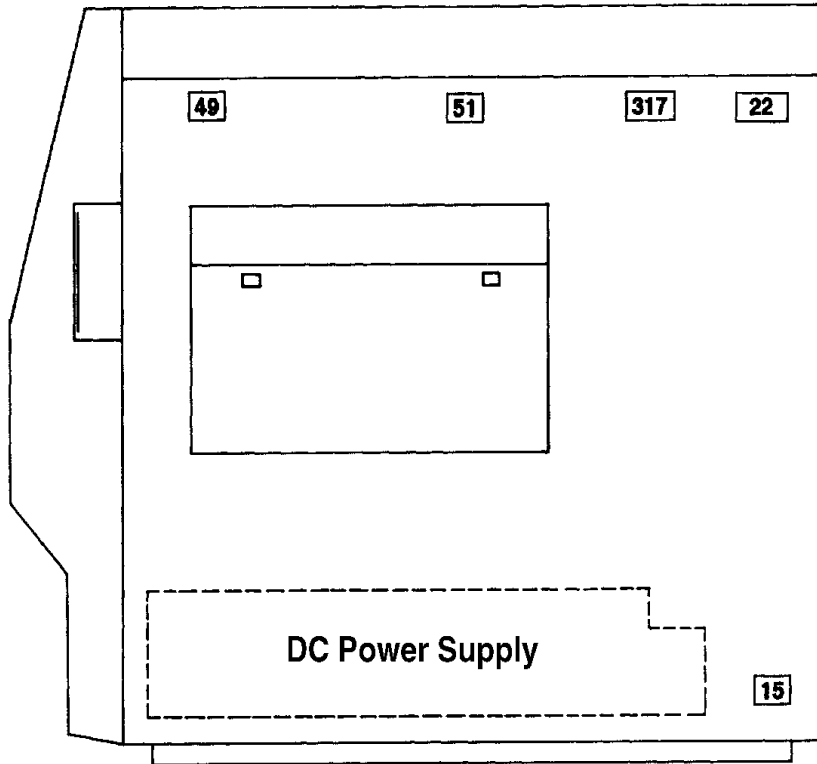

Connectors Inside the Top Cover

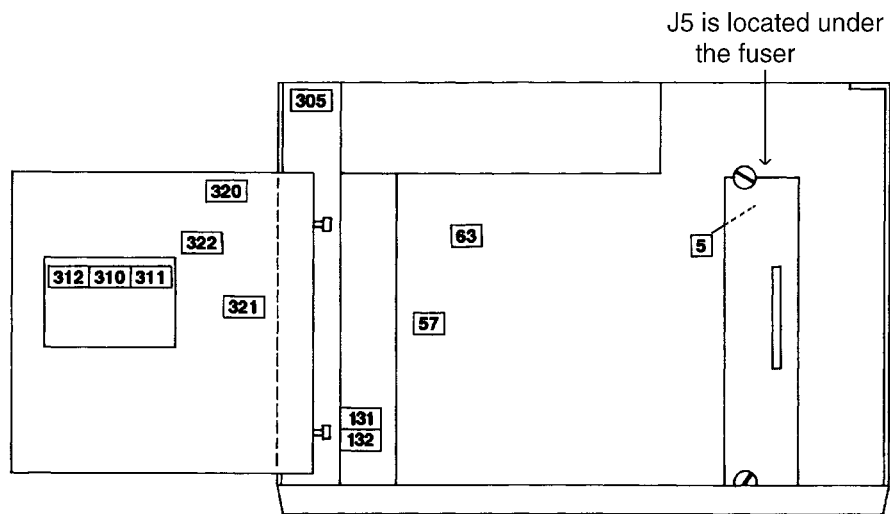

J/P 5

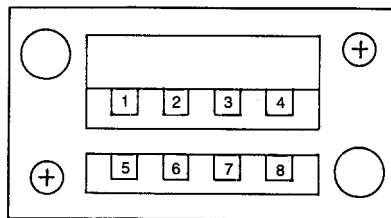

J/P 310

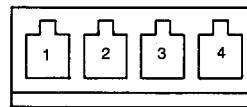

J/P 57

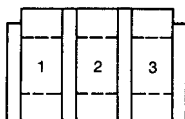

J/P 311

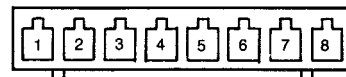

J/P 63

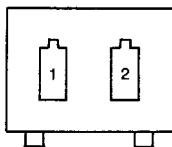

J/P 312

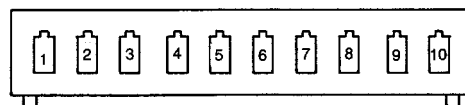

J/P 131-132

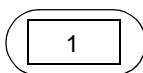

J/P 320

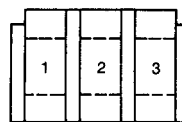

J/P 305

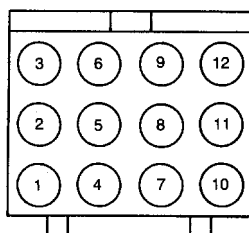

J/P 321

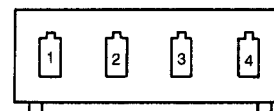

J/P 322

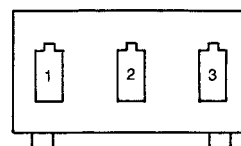

Connectors on the Back Cover

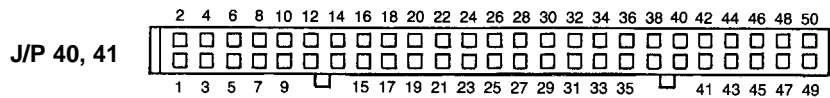
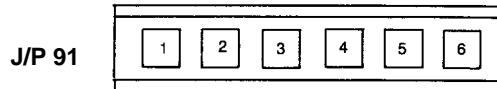
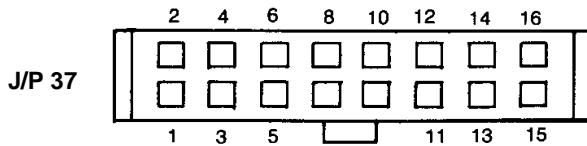
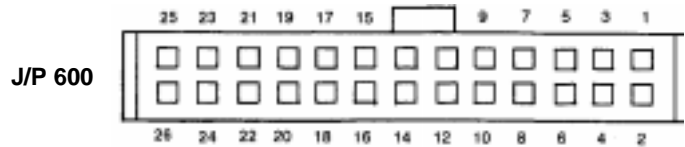
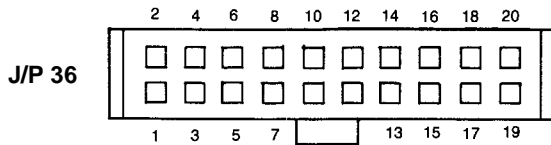
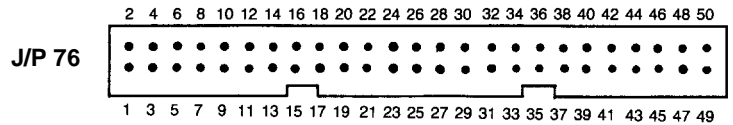
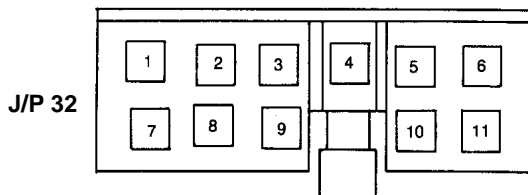
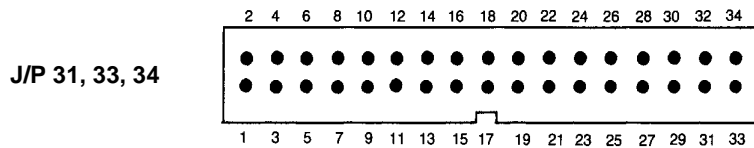
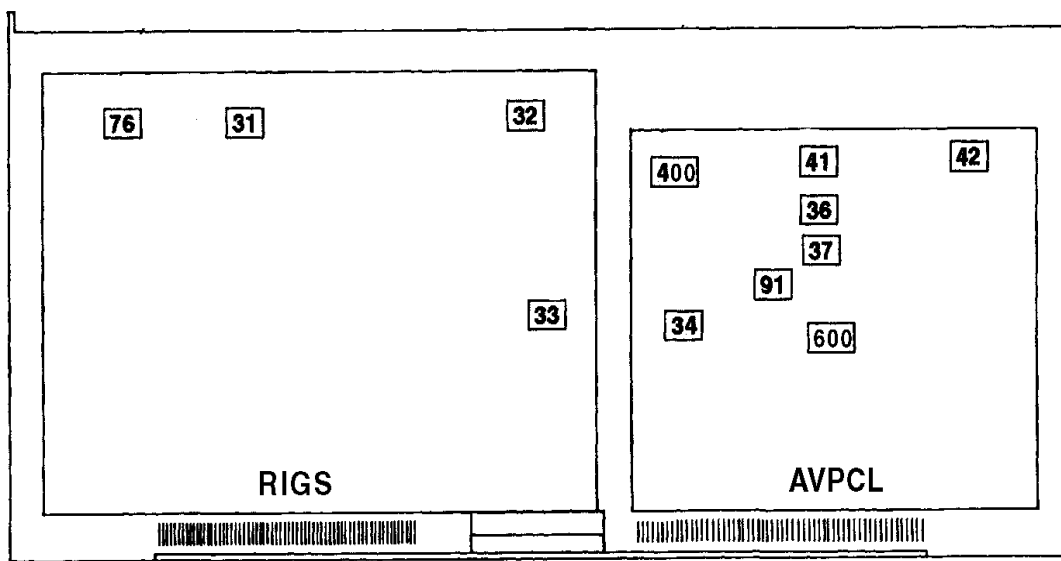

Connectors Inside the Back Cover (J/P2-14)

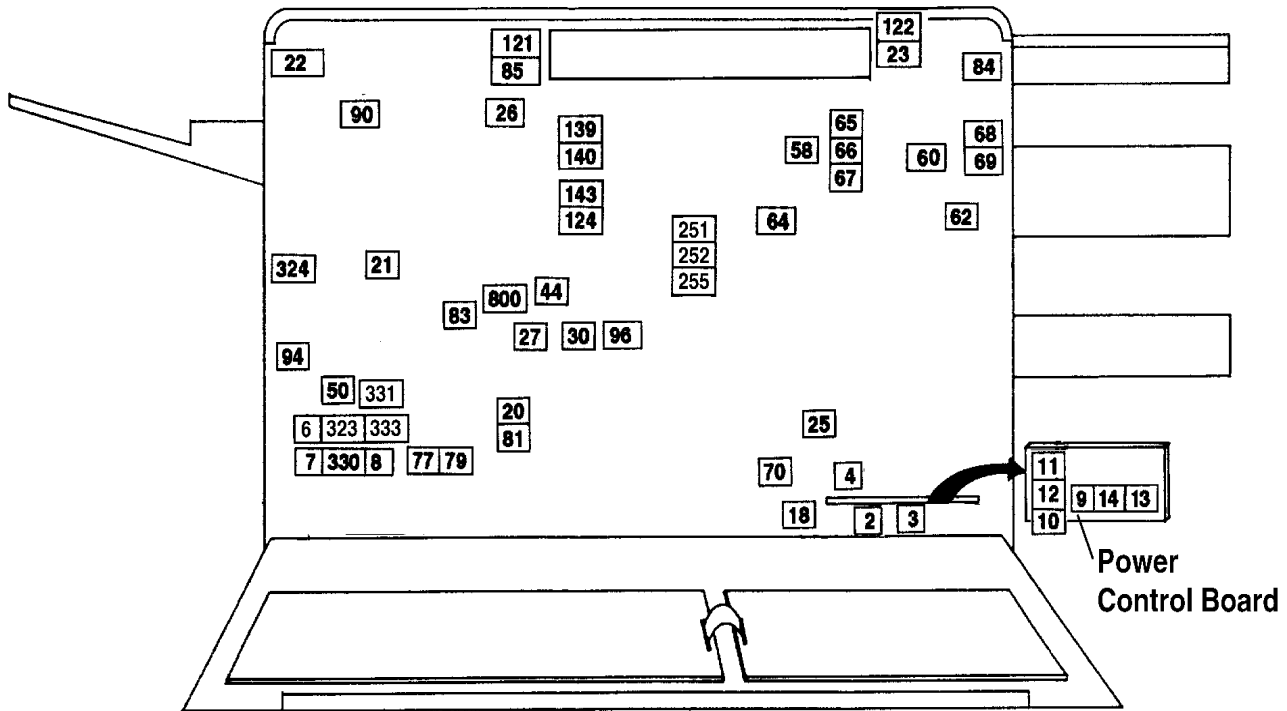

J/P 2, 3



J/P 4

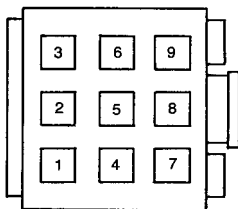

J/P 6

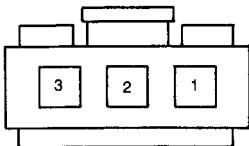

J/P 7

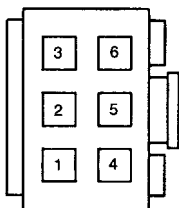

J/P 8

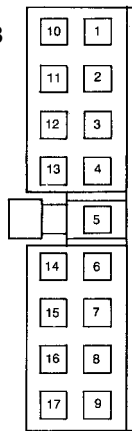

J/P 9



J/P 10

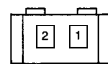

J/P 11

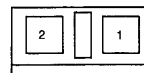

J/P 12

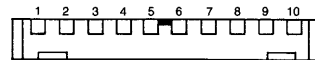

J/P 13

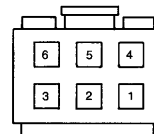

J/P 14

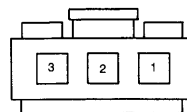

Connectors Inside the Back Cover (Continued) J/P 18-62

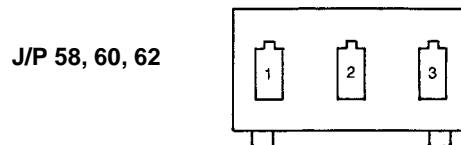
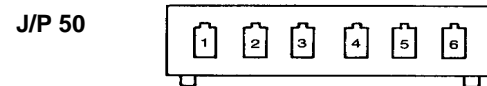
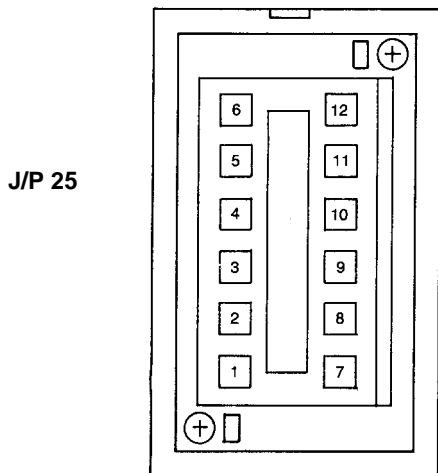
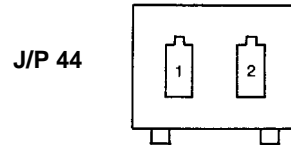
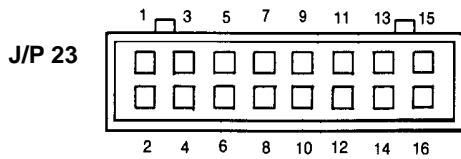
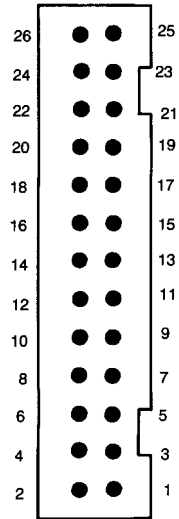
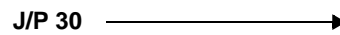
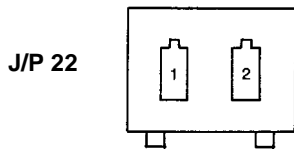
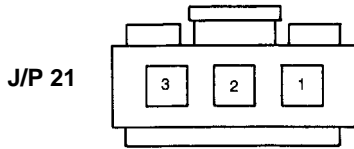
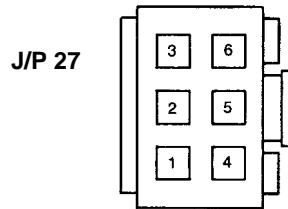
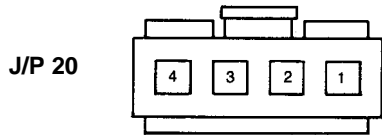
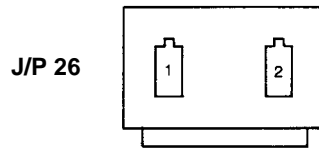
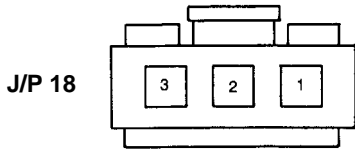

Connectors Inside the Back Cover (Continued) J/P 64-85

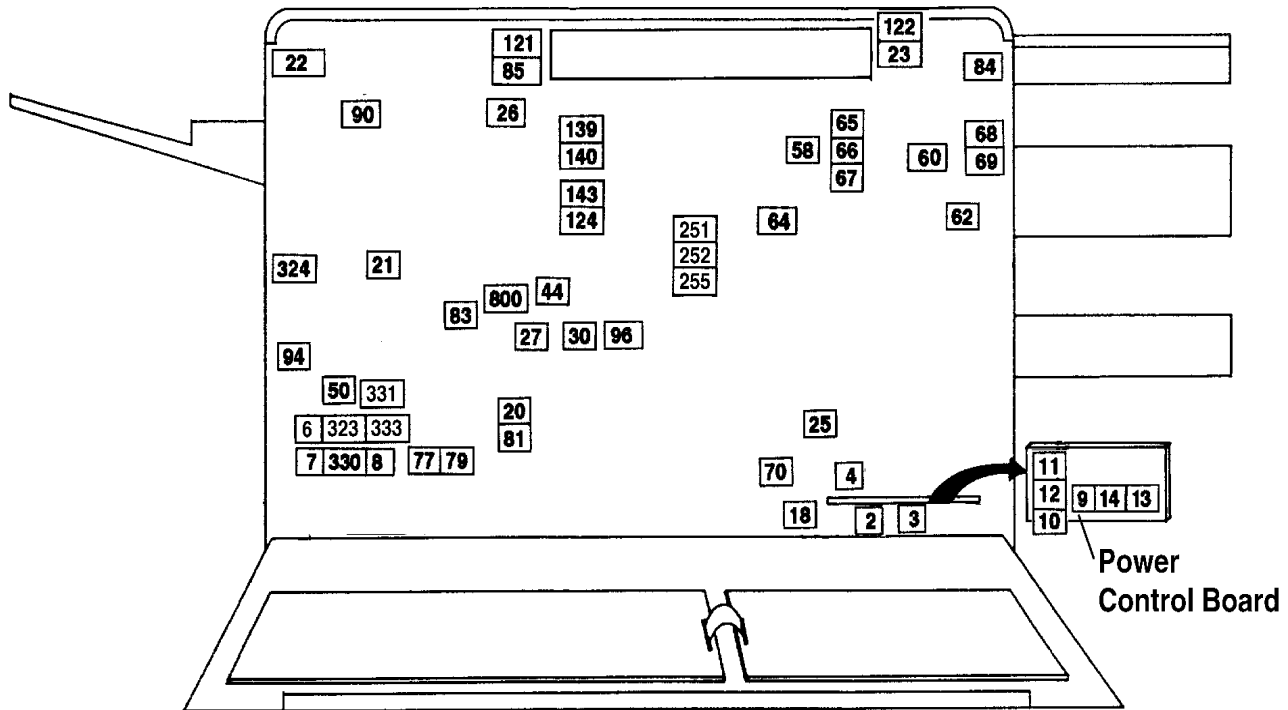

J/P 64

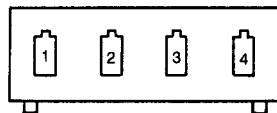

J/P 65, 66, 67, 68, 69, 70

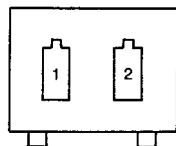

J/P 77

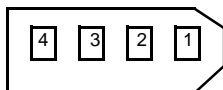

J/P 79

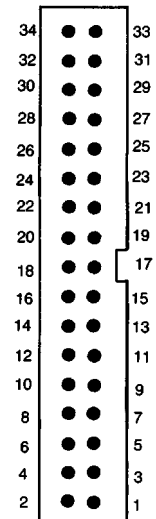

J/P 81, 83

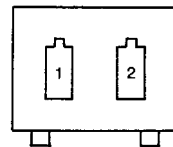

J/P 84

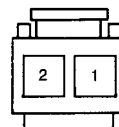

J/P 85

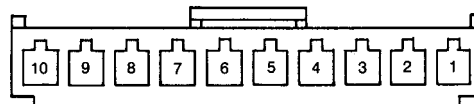

Connectors Inside the Back Cover (Continued) J/P 90-800

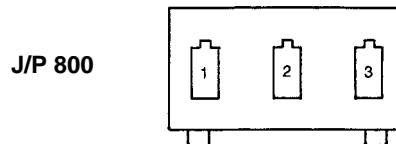
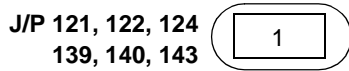
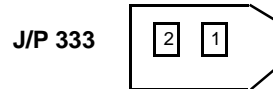
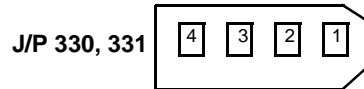
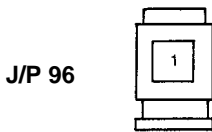
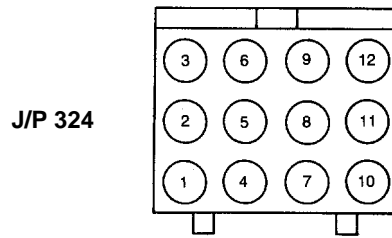
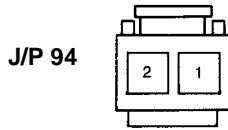
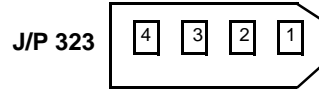
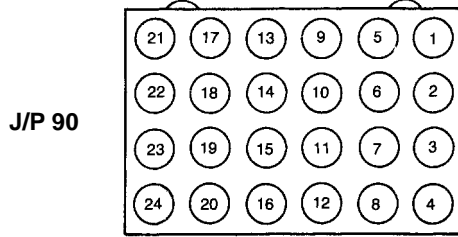

J/P 251, 252, 255 not illustrated

Voltage Isolation Diagrams

Voltage Isolation Diagrams

Use the following voltage isolation diagrams to locate the presence or loss of proper DC potentials within the printer.

-12 Vdc Circuits

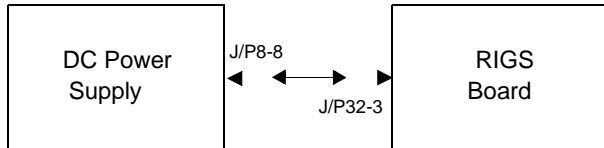

+5 Vdc Circuits

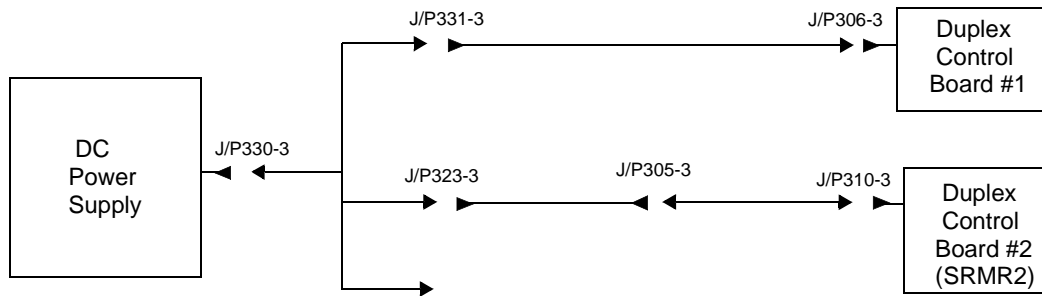

Voltage Isolation Diagrams

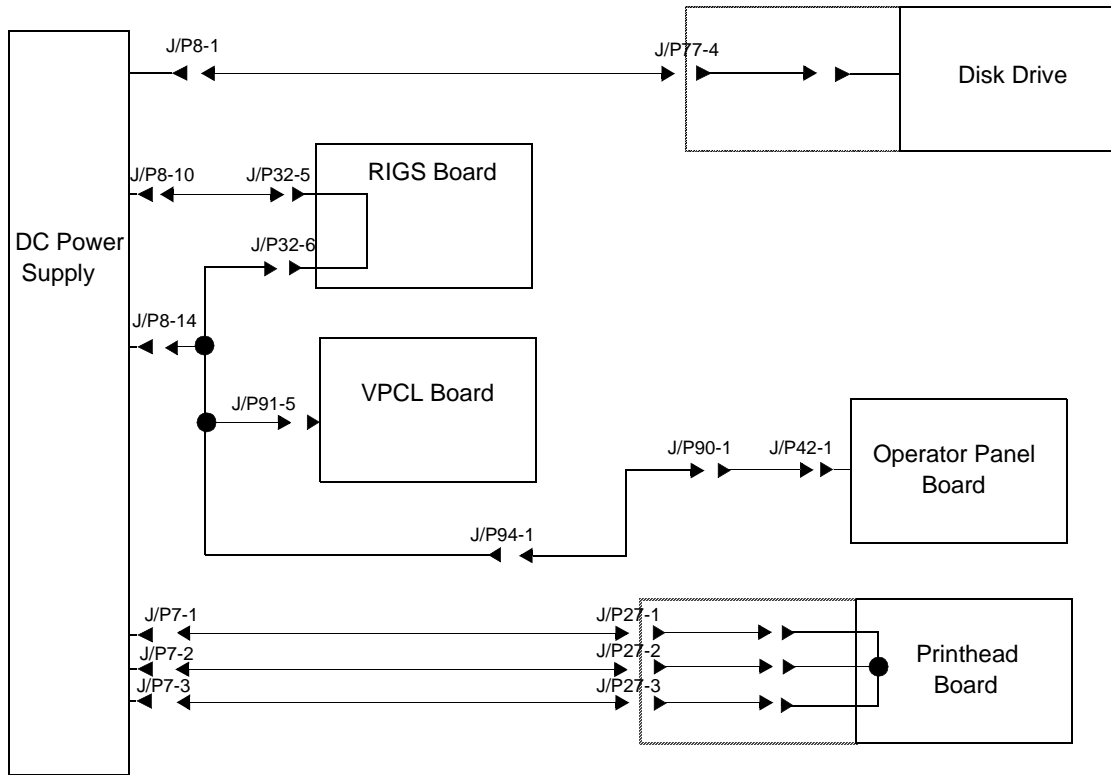

Voltage Isolation Diagrams

+12 Vdc Circuits

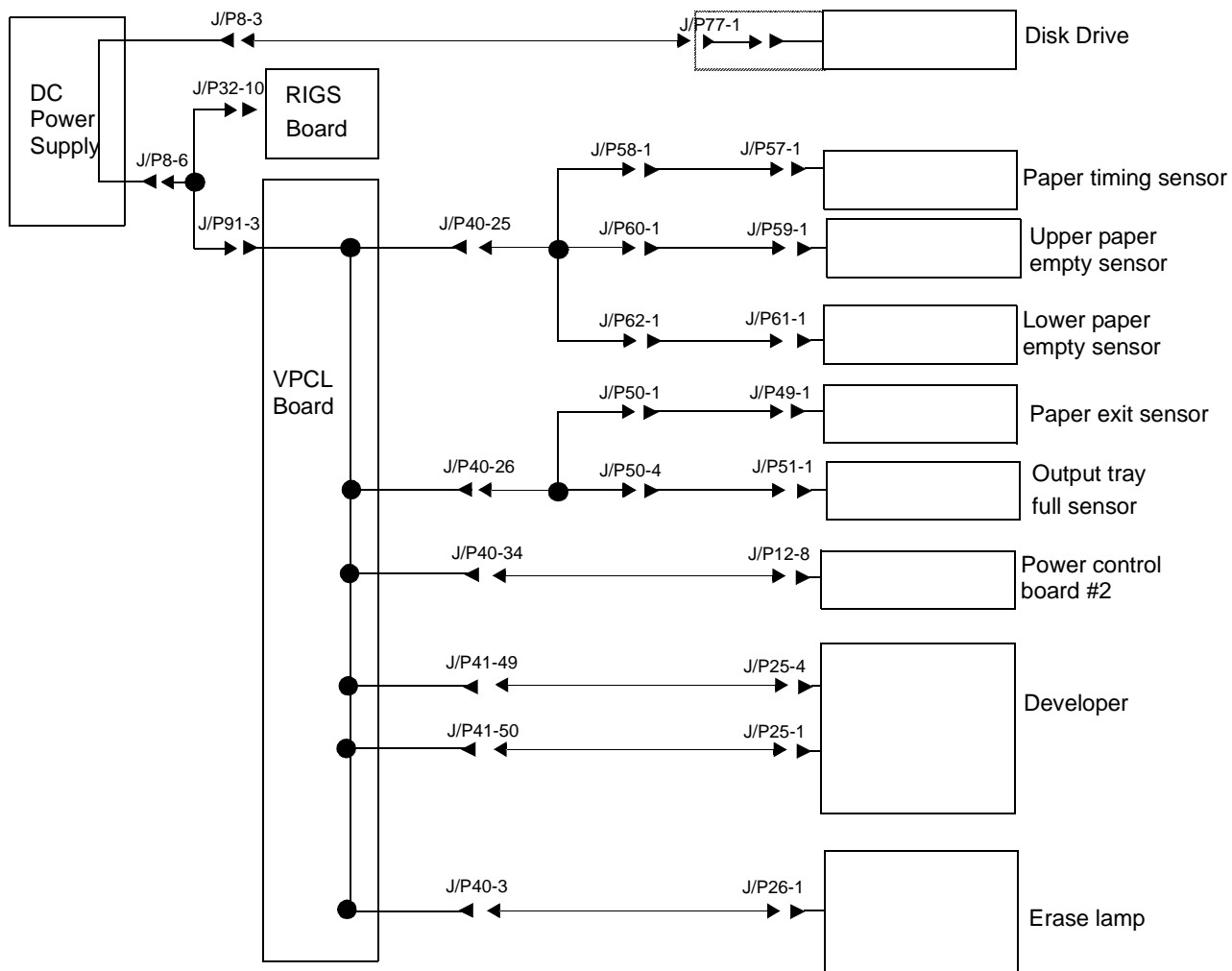

Voltage Isolation Diagrams

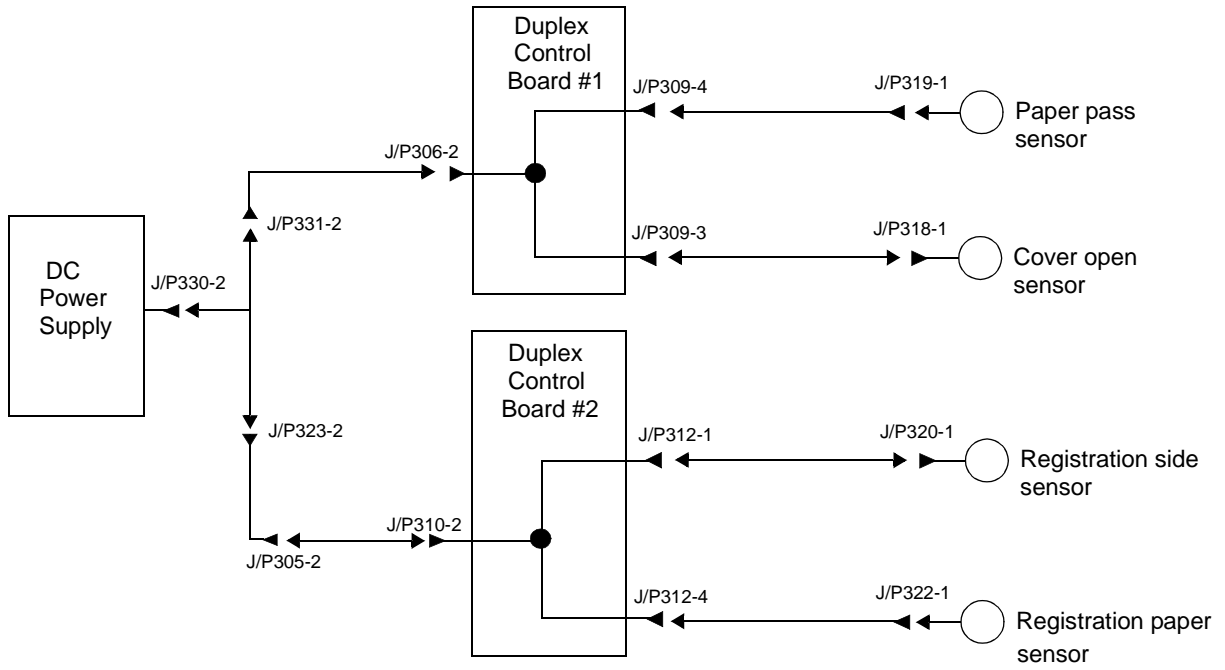

Voltage Isolation Diagrams

+24 Vdc Circuits

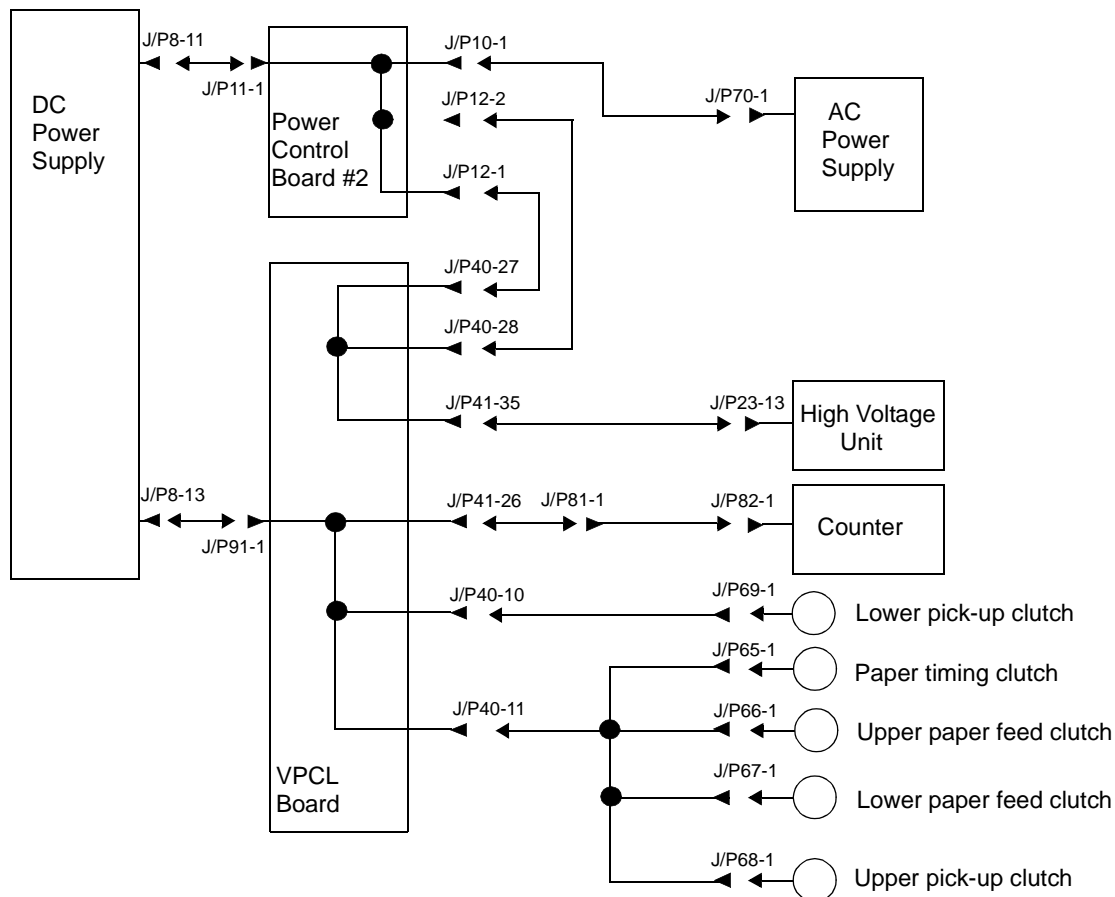
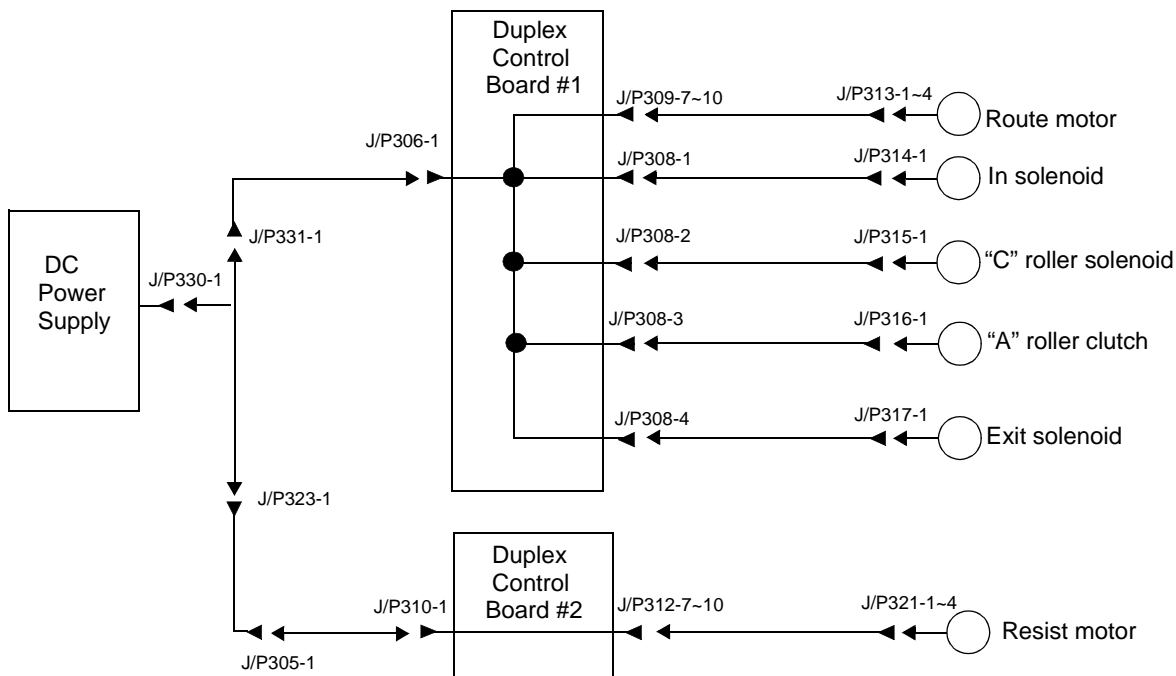

Ground System

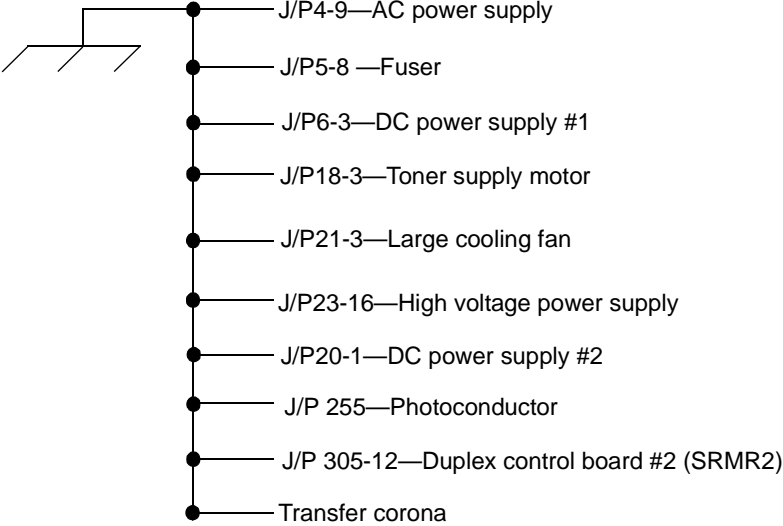

Host Interface Reference

Standard printers support two host interfaces: RS-232C and Centronics Parallel. User-level information about the installation, configuration, and use of these interfaces is included in the *The C40D Installation Manual*, C4672-90004, guides you through unpacking, setup, testing, and network configuration of your C40D printer.

RS-232C Host Interface

The default host interface for the printer is RS-232C. A printer is standard data terminal equipment (DTE), designed specifically for a direct connection to a standard data communication equipment (DCE) host. The standard signal definitions for DTE to DCE equipment are outlined on the chart that follows.

| Pin | Name | Signal Function |
|-----|--------|--|
| 1 | FG | Frame or chassis ground |
| 2 | TD | Transmitted data |
| 3 | RD | Received data |
| 4 | RST | Request to send |
| 5 | CTS | Clear to send |
| 6 | DSR | Data set ready (not used) |
| 7 | SG | Signal ground |
| 8 | DCD | Data carrier detect |
| 9 | | |
| 10 | | |
| 11 | (S)DCD | Secondary data carrier detect (not used) |
| 12 | (S)CTS | Secondary clear to send (not used) |
| 13 | (S)CTS | Secondary clear to send (not used) |
| 14 | (S)TD | Secondary transmitted data (not used) |
| 15 | TC | Transmitter clock |
| 16 | (S)RD | Secondary received data (not used) |
| 17 | RC | Receiver clock |
| 18 | RDC | Receiver debit clock (not used) |
| 19 | (S)RTS | Secondary receive to send (not used) |
| 20 | DTR | Data terminal ready |
| 21 | SQ | Signal quality detect (not used) |
| 22 | RI | Ring indicator (not used) |
| 23 | DRS | Data rate select (not used) |
| 24 | (TC) | External transmitter clock |
| 25 | BSY | Busy (not used) |

Standard DCE to DTE RS-232C Cable

The standard DCE host to the printer (DTE) pin configuration follows.

| Host Signal | DCE | | DTE | Printer Signal |
|-------------|-----|-------|-----|----------------|
| FG | 1 | ----- | 1 | FG |
| TD | 2 | ----- | 2 | TD |
| RD | 3 | ----- | 3 | RD |
| RTS | 4 | ----- | 4 | RTS |
| CTS | 5 | ----- | 5 | CTS |
| DSR | 6 | | 6 | DSR |
| SG | 7 | ----- | 7 | SG |
| DCD | 8 | | 8 | DCD |
| DTR | 20 | ----- | 20 | DTR |

Special Considerations for RS-232 Host Interface Users

The host computer may be using a non-DCE RS-232C port. If so, you may have to modify your cable or purchase a new cable with the proper pin assignments. Several possible alternate RS-232C cable configurations follow.

DTE Host to Printer (Option 1)

| Host Signal | DTE | | DTE | Printer Signal |
|-------------|-----|--|-----|----------------|
| GND | 1 | | 1 | GND |
| TD | 2 | | 2 | TD |
| RD | 3 | | 3 | RD |
| RTS | 4 | | 4 | RTS |
| CTS | 5 | | 5 | CTS |
| DSR | 6 | | 6 | DSR |
| GND | 7 | | 7 | GND |
| DCD | 8 | | 8 | DCD |
| DTR | 20 | | 20 | DTR |

Host Interface Reference

DTE Host to Printer (Option 2)

| Host Signal | DTE | DTE | Printer Signal |
|-------------|-----|-----|----------------|
| GND | 1 | 1 | GND |
| TD | 2 | 2 | TD |
| RD | 3 | 3 | RD |
| RTS | 4 | 4 | RTS |
| CTS | 5 | 5 | CTS |
| DSR | 6 | 6 | DSR |
| GND | 7 | 7 | GND |
| DCD | 8 | 8 | DCD |
| DTR | 20 | 20 | DTR |

IBM PC/XT to Printer

Normally, the IBM PC/XT comes with a parallel interface for the printer with a 25-pin female connector. To run RS-232, you must install a serial board, which will have a male connector.

| PC/XT Signal | DTE | DTE | Printer Signal |
|--------------|-----|-----|----------------|
| ----- | 1 | 1 | FG |
| TD | 2 | 2 | TD |
| RD | 3 | 3 | RD |
| RTS | 4 | 4 | RTS |
| CTS | 5 | 5 | CTS |
| DSR | 6 | 6 | DSR |
| SG | 7 | 7 | SG |
| DCD | 8 | 8 | DCD |
| DTR | 20 | 20 | DTR |

IBM PC/AT to Printer

Normally, the IBM AT comes with a 9-pin serial connector.

| PC/AT Signal | DCE | DTE | Printer Signal |
|--------------|-----|-----|----------------|
| DCD | 1 | 1 | FG |
| RD | 2 | 2 | TD |
| TD | 3 | 3 | RD |
| DTR | 4 | 4 | RTS |
| SG | 5 | 5 | CTS |
| DSR | 6 | 6 | ----- |
| RTS | 7 | 7 | SG |
| CTS | 8 | 8 | DCD |
| RI | 9 | 20 | DTR |

Macintosh Communication Port to Printer

Normally, the Macintosh comes with a 9-pin male connector.

| Macintosh Signal | DCE | DTE | Printer Signal |
|------------------|-----|-----|----------------|
| FG | 1 | 1 | FG |
| | 2 | 2 | TD |
| SG | 3 | 3 | RD |
| | 4 | 4 | RTS |
| TD | 5 | 5 | CTS |
| | 6 | 6 | ----- |
| DSR | 7 | 7 | SG |
| | 8 | 8 | DCD |
| RD | 9 | 20 | DTR |

Centronics Parallel Host Interface

The signal definitions defined below are for the 1284 compatible mode. This interface also supports other 1284 compatible modes.

| Pin | Signal Name | Function |
|------------|--------------------|---------------------------|
| 1 | DS | Data strobe (active low) |
| 2 | DB0 | Data bit 0 |
| 3 | DB1 | Data bit 1 |
| 4 | DB2 | Data bit 2 |
| 5 | DB3 | Data bit 3 |
| 6 | DB4 | Data bit 4 |
| 7 | DB5 | Data bit 5 |
| 8 | DB6 | Data bit 6 |
| 9 | DB7 | Data bit 7 |
| 10 | ACK | Acknowledge (active low) |
| 11 | BSY | Busy (active high) |
| 12 | PE | Paper empty (active high) |
| 13 | SEL | Select (active high) |
| 14 | AF | Auto feed |
| 15 | | Not used |
| 16 | SG | Signal ground |
| 17 | FG | Frame or chassis ground |
| 18 | PLH | Peripheral logic high |
| 19 to 30 | | Signal ground |
| 31 | IP | INIT |
| 32 | ERR | Error (active low) |
| 33 to 35 | | Not used |
| 36 | SI | Select input |

Special Considerations for Centronics Parallel Interface Users

For DOS host computers, add the following line to the AUTOEXEC.BAT file:

```
MODE PRN,,P
```

To edit the AUTOEXEC.BAT file, use any text editor or the EDLIN facility of DOS. If you do not know how to edit this file, refer to the reference manual that came with the DOS software.

IBM Parallel to Printer

| Host Signal | | | Printer Signal | |
|-------------|----|-------|----------------|-----|
| DS | 1 | ----- | 1 | DS |
| DB0 | 2 | ----- | 2 | DB0 |
| DB1 | 3 | ----- | 3 | DB1 |
| DB2 | 4 | ----- | 4 | DB2 |
| DB3 | 5 | ----- | 5 | DB3 |
| DB4 | 6 | ----- | 6 | DB4 |
| DB5 | 7 | ----- | 7 | DB5 |
| DB6 | 8 | ----- | 8 | DB6 |
| DB7 | 9 | ----- | 9 | DB7 |
| ACK | 10 | ----- | 10 | ACK |
| BSY | 11 | ----- | 11 | BSY |
| PE | 12 | ----- | 12 | PE |
| SEL | 13 | ----- | 13 | SEL |
| AF | 14 | ----- | 14 | AF |
| ERR | 15 | ----- | 32 | ERR |
| IP | 6 | ----- | 31 | IP |
| SI | 17 | ----- | 36 | SI |
| GND | 18 | ----- | 33 | GND |
| GND | 19 | ----- | 19 | GND |
| GND | 20 | ----- | 21 | GND |
| GND | 21 | ----- | 23 | GND |
| GND | 22 | ----- | 25 | GND |
| GND | 23 | ----- | 27 | GND |
| GND | 24 | ----- | 29 | GND |
| GND | 25 | ----- | 30 | GND |

Host Interface Reference

***Removal/
Replacement
Procedures***

Contents

Removal/Replacement Procedures

| | |
|--|------|
| Before You Begin | 7-4 |
| Power Considerations | 7-4 |
| Photoconductor Removal | 7-4 |
| Front Cover Removal | 7-5 |
| Back Cover Removal | 7-6 |
| Left Side Cover Removal | 7-7 |
| Right Side Cover Removal | 7-8 |
| Vacuum Transport Unit Removal | 7-9 |
| Rear Duplex Cover Removal | 7-10 |
| Front Duplex Cover Removal | 7-11 |
| Operator Panel Removal | 7-12 |
| Counter Removal | 7-13 |
| RIGS Board Removal | 7-14 |
| VPCL Board Removal | 7-15 |
| Printhead Assembly Removal | 7-16 |
| Printhead Circuit Board (ARIF) Removal | 7-18 |
| Hard Disk Drive Housing Removal | 7-19 |
| Floppy and Hard Disk Drive Removal | 7-20 |
| Cooling Fan Removal | 7-21 |
| Toner Motor Removal | 7-22 |
| AC Power Supply Removal | 7-24 |
| DC Power Supply Removal | 7-26 |
| High Voltage Unit Removal | 7-27 |
| Photoconductor Seam Sensor Removal | 7-28 |
| Photoconductor Rear Guide Rail Removal | 7-30 |
| Power Control Board Removal | 7-33 |
| Upper or Lower Paper Size Sensor Removal | 7-34 |
| Upper Cassette Mount Removal | 7-35 |
| Lower Cassette Mount Removal | 7-40 |
| Upper Paper Guide Removal | 7-45 |
| Upper Paper Guide Roller Removal | 7-47 |
| Lower Paper Guide Removal | 7-48 |
| Paper Timing Guide Removal | 7-49 |
| Cleaner Drive Belt Removal | 7-51 |
| Cleaner Drive Removal | 7-52 |

| | |
|--|------|
| Fuser Drive Belt Removal | 7-53 |
| Fuser Drive Removal | 7-54 |
| Paper Feed Drive Belt Removal | 7-55 |
| Paper Timing Roller Removal | 7-56 |
| Upper Feed Roller Removal | 7-57 |
| Lower Feed Roller Removal | 7-58 |
| Upper Pick-Up Roller Removal | 7-59 |
| Pick-Up Roller Drive Idler Removal | 7-60 |
| Pick-Up Roller Drive Gear Removal | 7-61 |
| Lower Pick-Up Roller Removal | 7-62 |
| Exit Assembly Removal | 7-63 |
| Exit Pinch Roller Removal | 7-65 |
| Upper Static Brush Removal | 7-67 |
| Lower Static Brush Removal | 7-68 |
| Exit Roller Assembly Removal | 7-69 |
| Exit Cover Removal | 7-71 |
| Paper Exit Sensor Removal | 7-73 |
| Paper Full Sensor Removal | 7-74 |
| Front Cover Interlock Switch Removal | 7-75 |
| Back Cover Interlock Switch Removal | 7-76 |
| Top Cover Interlock Switch Removal | 7-77 |
| Erase Lamp Removal | 7-78 |
| EP Cover Removal | 7-79 |
| Main Motor Removal | 7-82 |
| Main Gear Drive Removal | 7-85 |
| Duplex Control Board #1 Removal | 7-86 |
| Duplex Control Board #2 Removal | 7-87 |
| Duplex Tray Registration Motor Removal | 7-88 |
| Duplex Skew Correction Cable Removal | 7-89 |
| Upper Duplex Drive/Clutch Assembly Removal | 7-91 |
| Duplex Route Motor/Solenoid Assembly Removal | 7-92 |
| “A” Roller Removal | 7-93 |
| “B” Roller Removal | 7-94 |
| “C” Roller Removal | 7-96 |
| “C” Roller Solenoid Removal | 7-97 |
| Duplex Route Separator Removal | 7-98 |
| Duplex Paper Path Sensor Removal | 7-99 |

Removal/Replacement Procedures

This section includes step-by-step instructions for removing all field service replaceable parts in the printer. Each part is addressed under its own heading, as outlined on the preceding contents pages.

Before You Begin

To remove a part, follow the instructions provided. To replace a part, follow the steps in reverse order unless otherwise noted. During reassembly, make sure to reconnect all connectors properly and seat gears and other moving parts properly.

Power Considerations

Before removing a part, make sure the printer is turned off and the power cord is disconnected.

Photoconductor Removal

If it is necessary to remove the photoconductor as part of a removal procedure, make sure to place it in its protective packaging.

When you replace the photoconductor, run at least 500 prints before checking print quality. This number of prints is required to “synch” the new PC belt to the developer.

Front Cover Removal

- 1 Open the front cover.
- 2 While holding the cover up halfway, unhook the strap from the right side.
- 3 Remove the strap from the left side.
- 4 Slide the front cover to the right off its hinges.

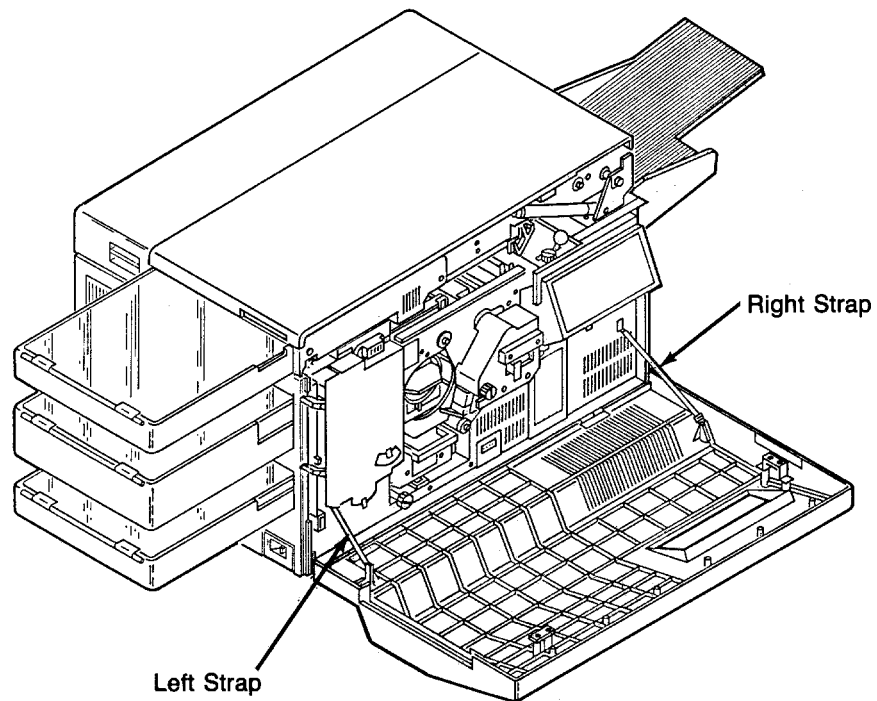

Back Cover Removal

- 1 Remove all external cables and attachments, including the printer's power cord.
- 2 Open the top and back covers.
- 3 Loosen the two thumb screws on the drive side of the top chassis and pull the back cover down.
- 4 Disconnect CN31, CN32, CN37, CN40, CN41, CN91, CN600, and CN36.
- 5 Disconnect the hard drive's data cable.
- 6 Remove the mounting screws holding the back cover hinge to the printer.
- 7 While supporting the back cover, remove the screw holding each strap.
- Caution: hold the cloth strap to avoid throwing the screw as it comes loose.
- 8 Lift the back cover up and away from the printer.

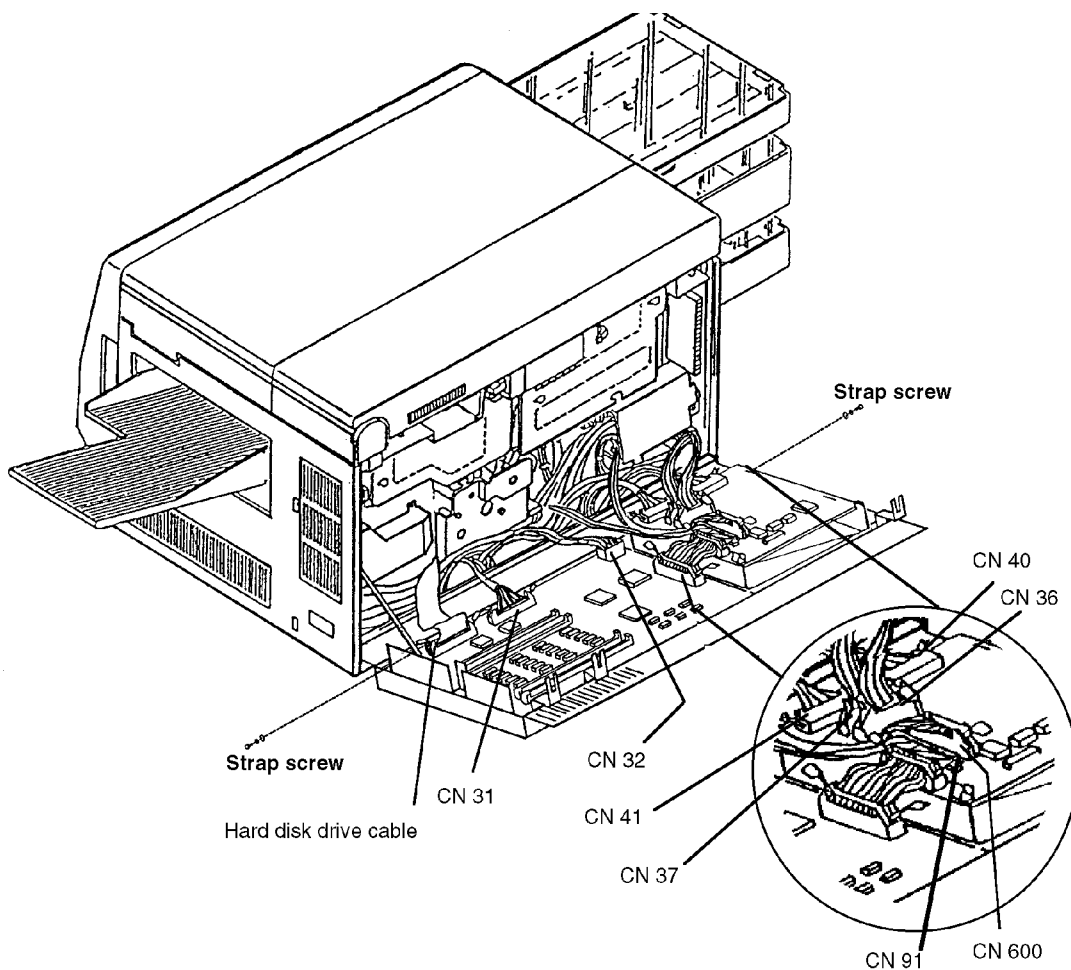

Left Side Cover Removal

- 1 Open the top, back, and front covers.
- 2 Remove the duplex tray by disconnecting P305 and loosening the two thumb screws.
- 3 Remove the upper and lower paper cassettes.
- 4 Loosen the two screws for the left side cover.
- 5 Lift the cover up and away from the printer.

Replacement Note:

When reinstalling, make sure the inside mounting tabs are properly positioned.

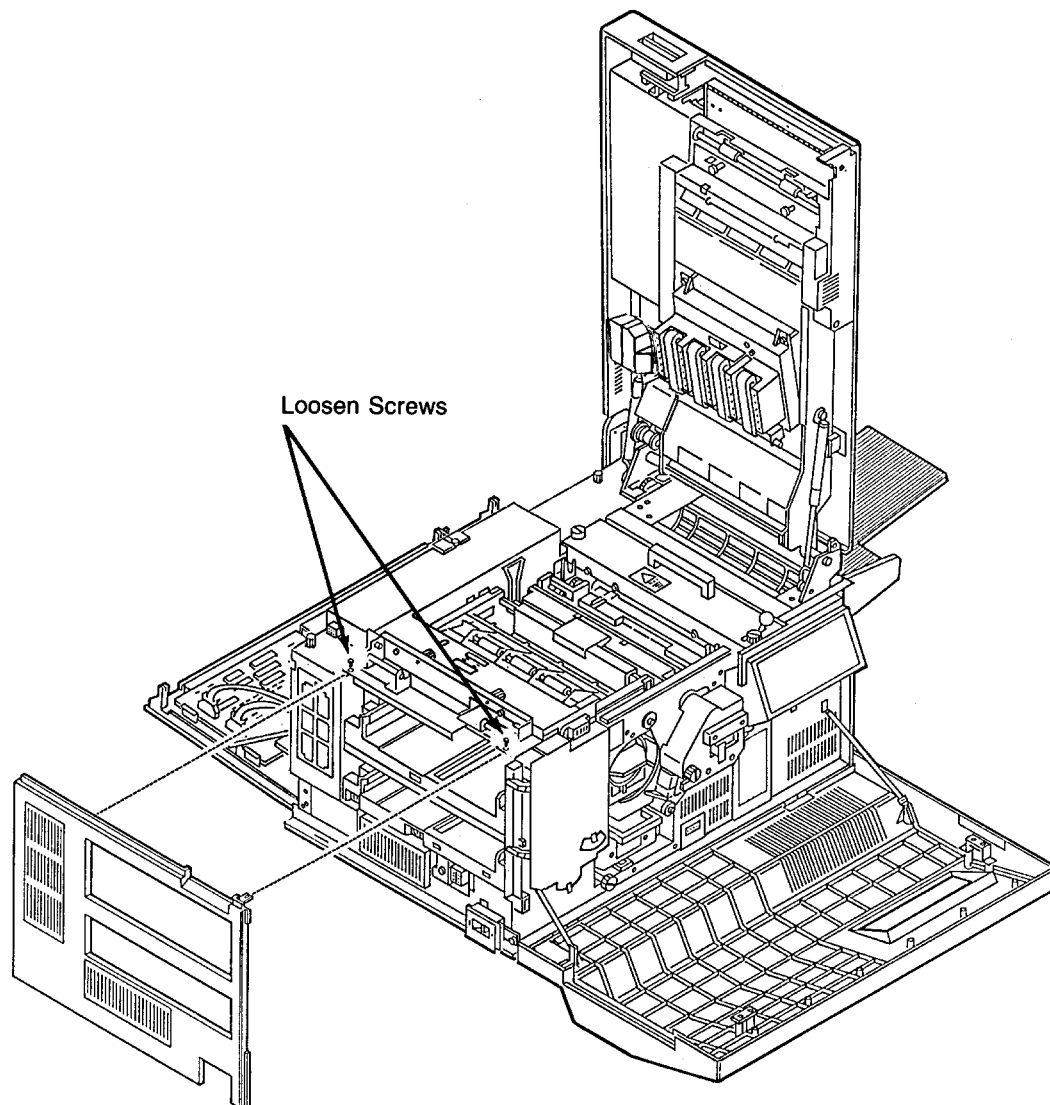

Right Side Cover Removal

Right Side Cover Removal

Note: The service kit is attached inside the right side cover.

- 1 Remove the paper output tray.
- 2 Open the top, back, and front covers.
- 3 Remove the two screws holding the right side cover in place.
- 4 Close the top cover.
- 5 Pull the cover out and away from the printer.

Replacement Note:

Tighten the screws first. Then, gently lift the bottom tabs into place.

Note: Hold the top of the right side cover in place as you open the top cover. (This avoids the possibility of damaging the top cover.)

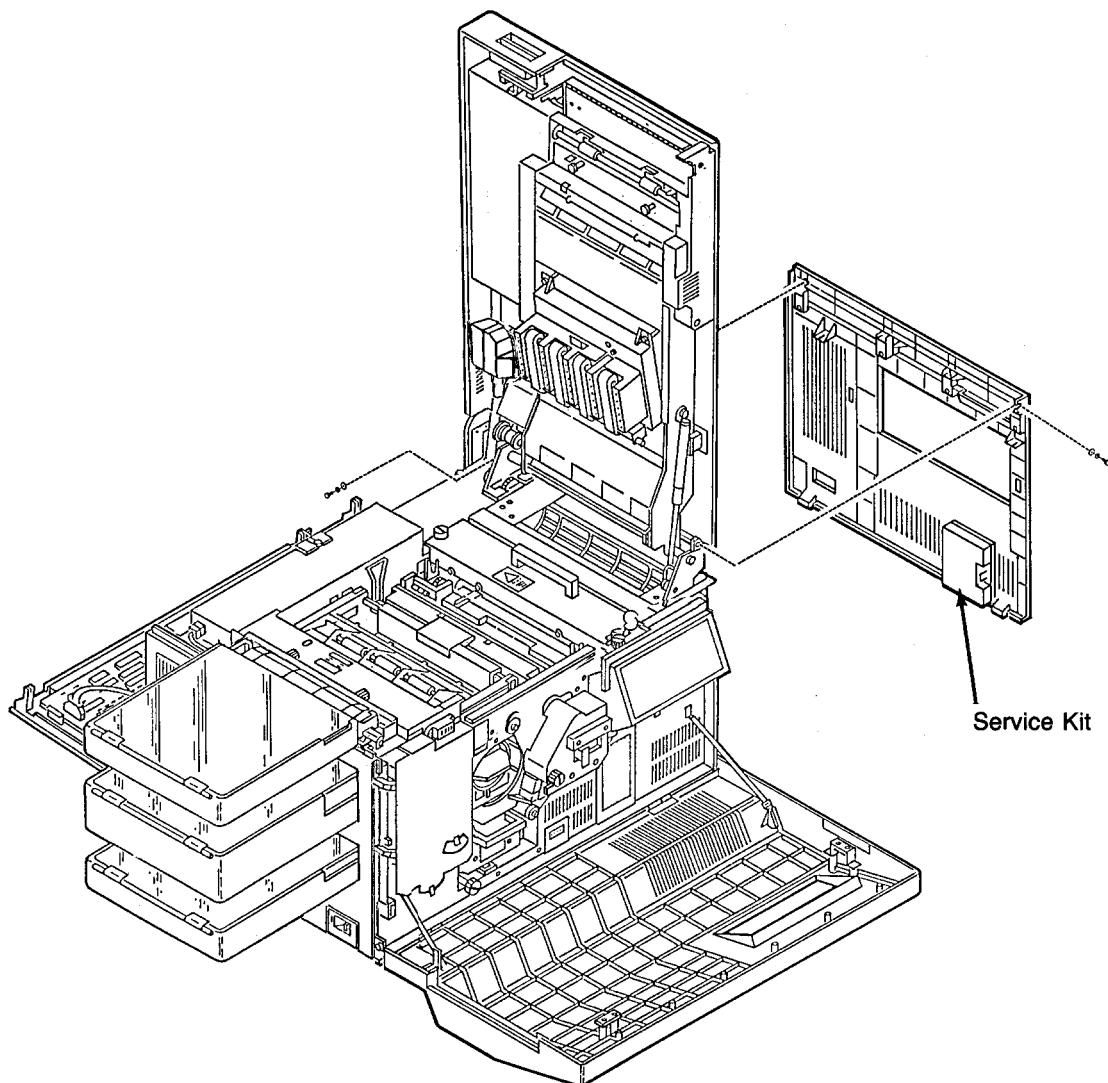

Vacuum Transport Unit Removal

- 1 Open the top cover.
- 2 Remove the upper duplex roller cover (four screws).
- 3 Remove the lower duplex roller cover (four screws).
- 4 Disconnect CN22.
- 5 Remove the C-clip from the gas spring on the side marked "up." Gently move the gas spring out of the way so it does not block the wire harness area.
- 6 Remove the four harness stays holding the cable in place.
- 7 Remove the three ground screws.
- 8 Remove the vacuum transport (four screws).

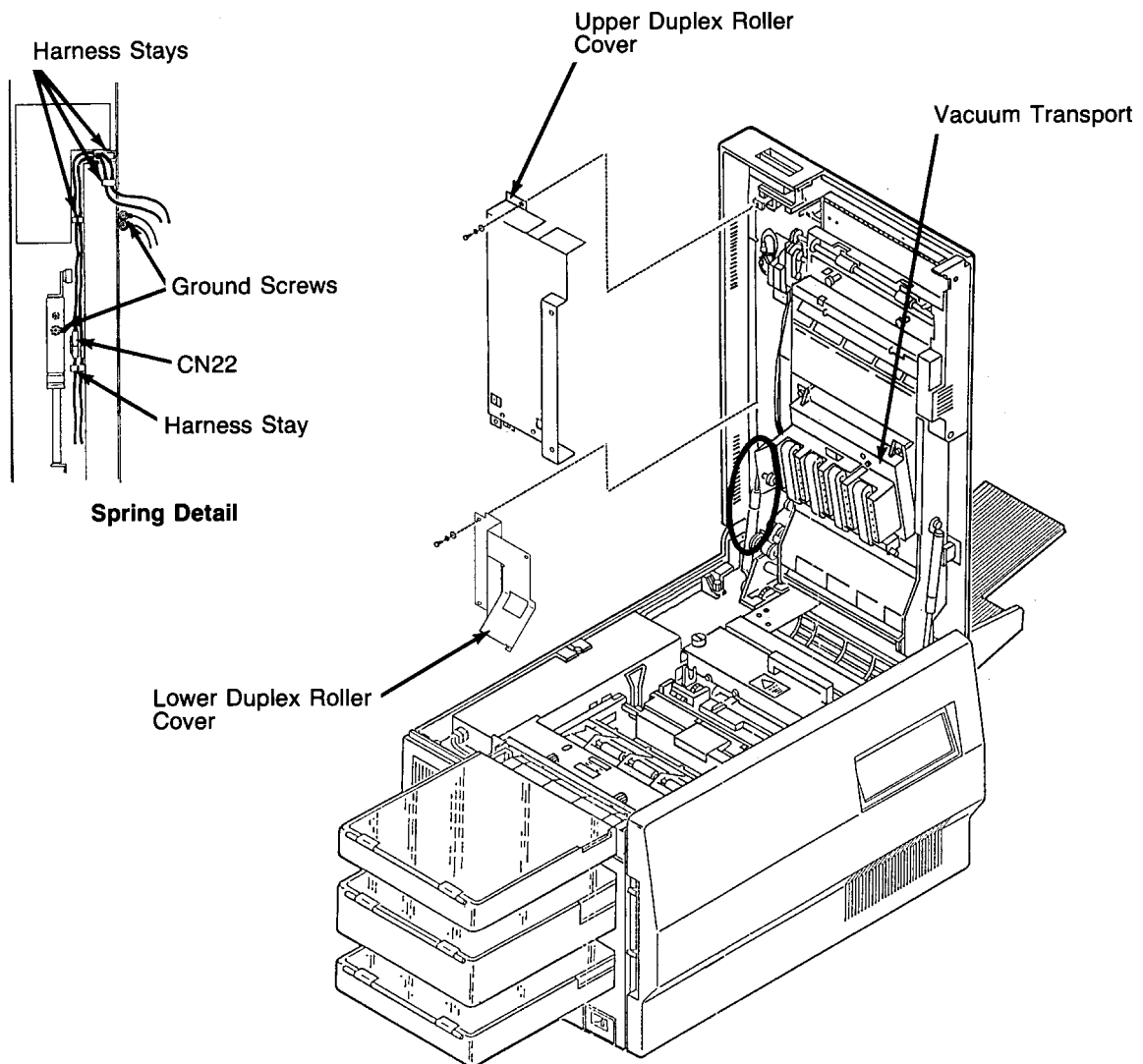

Rear Duplex Cover Removal

- 1 Open the top cover.
- 2 Remove the lower screw for the rear cover.
- 3 While supporting the cover, remove the upper screw for the rear cover.

Replacement Note:

Do not substitute longer screws to hold the rear cover in place.

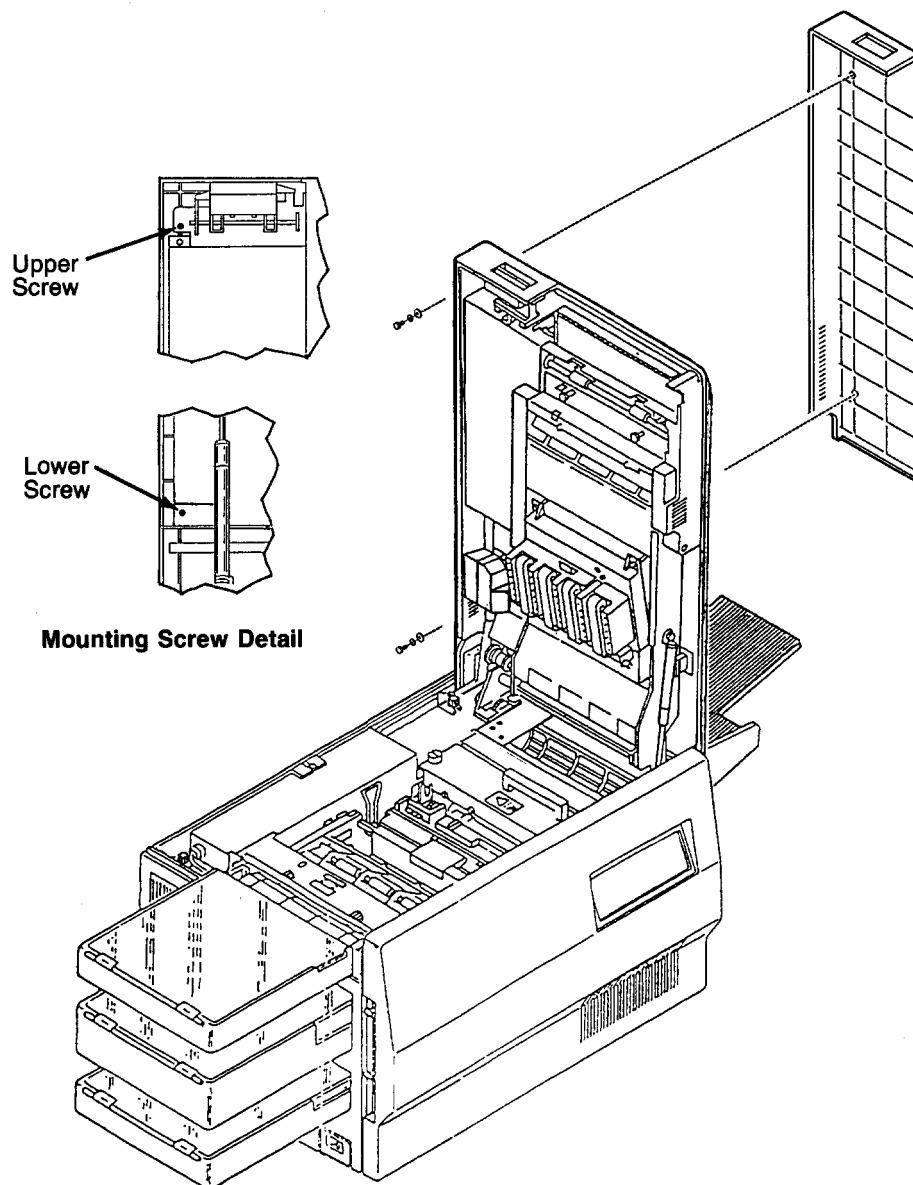

Front Duplex Cover Removal

- 1 Open the top cover.
- 2 Remove the rear cover. (Refer to [page 7-10.](#))
- 3 Close the top cover.
- 4 Open the front cover.
- 5 Remove the C-clip on each gas spring.
- 6 While supporting the cover, remove each gas spring from its post and lower it.
- 7 Close the front cover.
- 8 Remove the front hinges from the top cover (two screws each).
- 9 Remove the two screws from each front cover hinge.

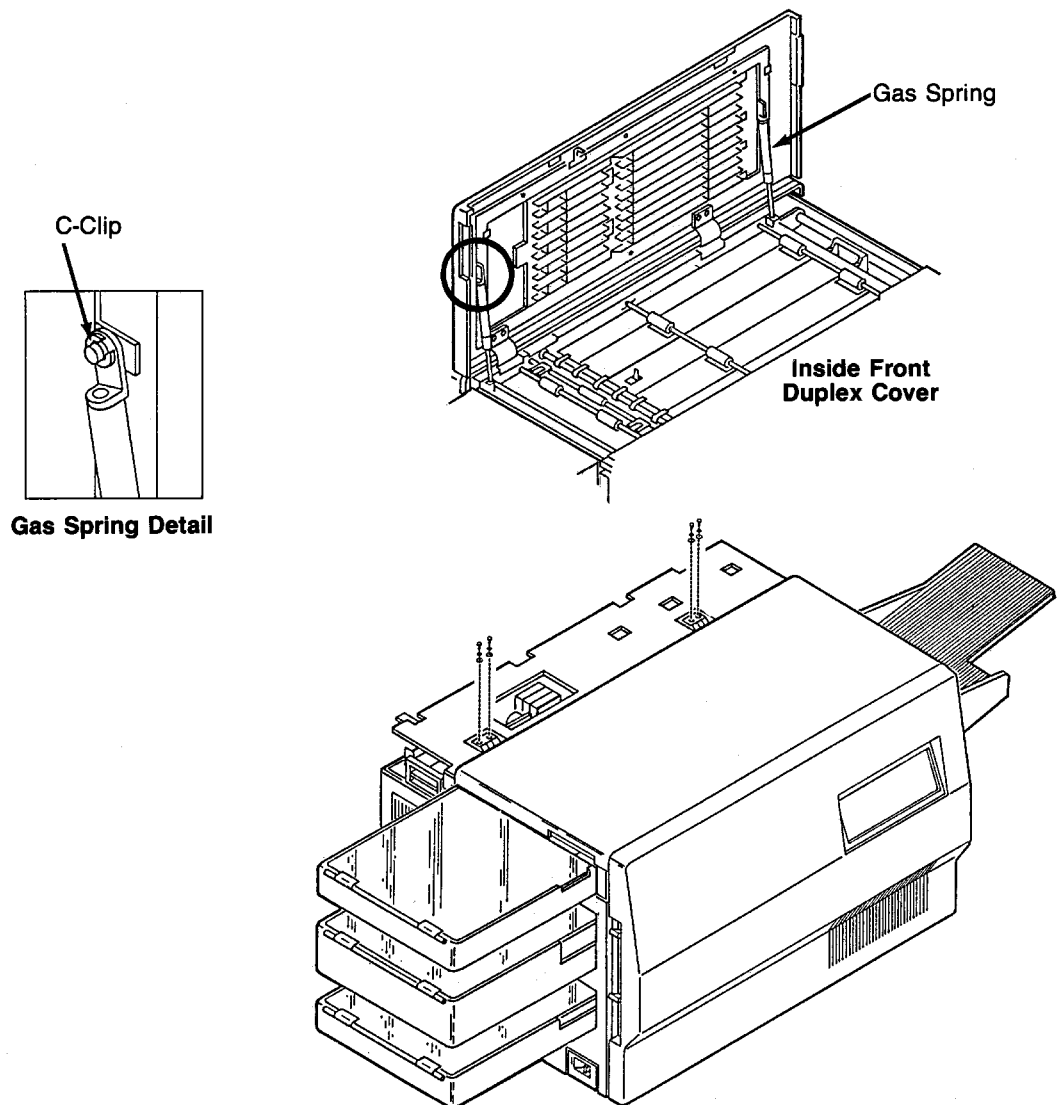

Operator Panel Removal

Operator Panel Removal

- 1 Open the front cover.
- 2 Remove the two screws holding the operator panel in place.
- 3 Disconnect CN42.
- 4 Remove the ground screw.

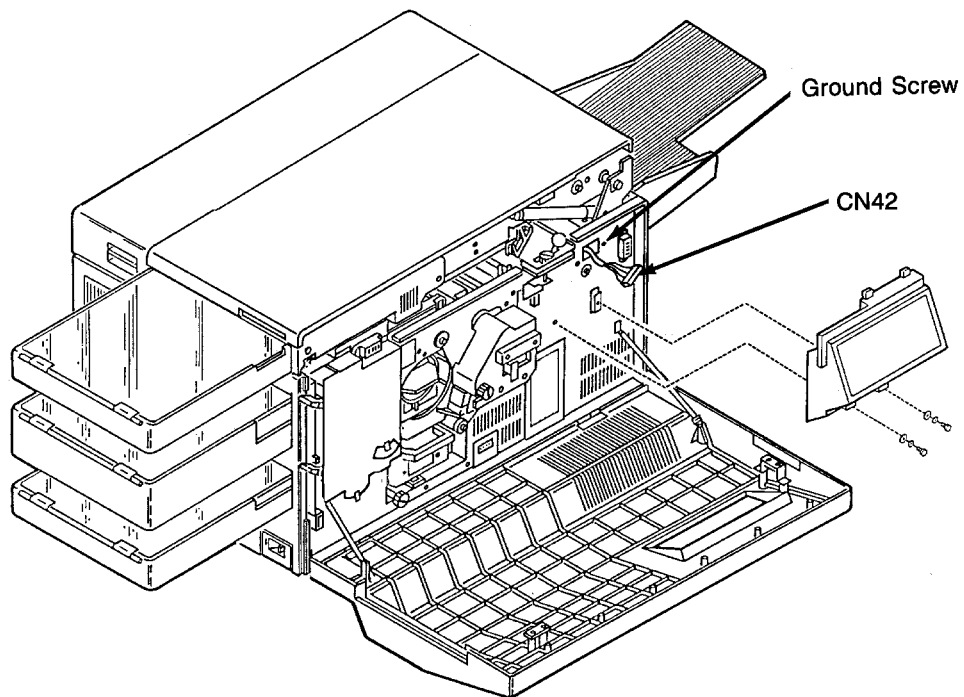

Counter Removal

- 1 Open the front cover.
- 2 Remove the screw holding the counter in place.
- 3 Pull out the counter.
- 4 Disconnect CN82.

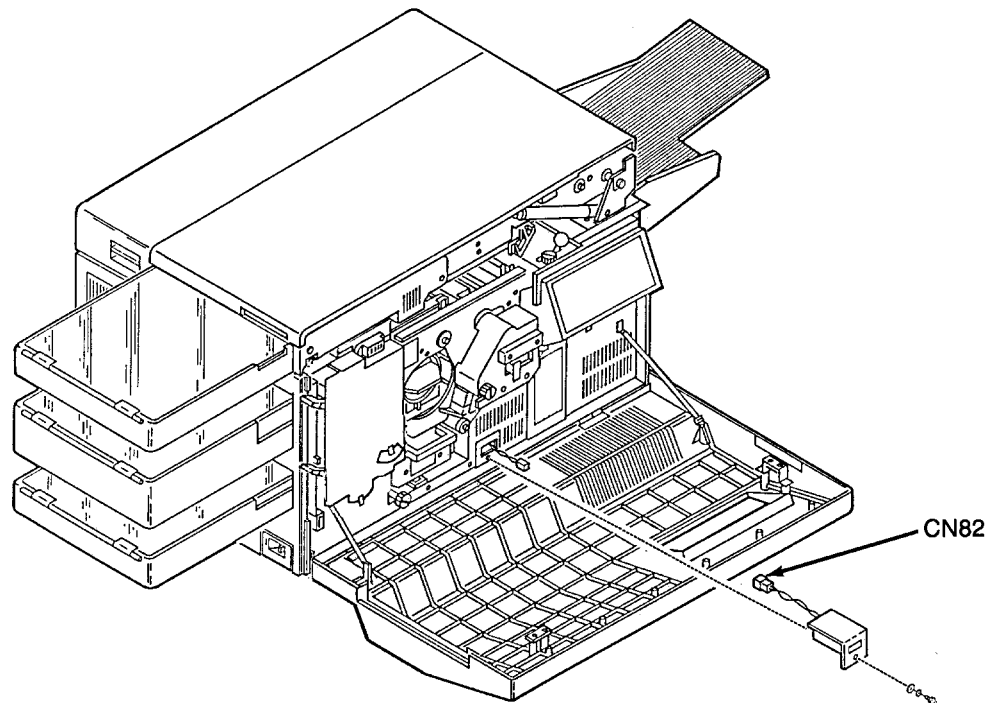

RIGS Board Removal

RIGS Board Removal

- 1 Remove any installed flex IO cards.
- 2 Open the back cover.
- 3 Disconnect CN31, CN32, and CN33.
- 4 Disconnect the hard drive's data cable.
- 5 Remove the eight screws holding the board in place.
- 6 Remove the RIGS board.

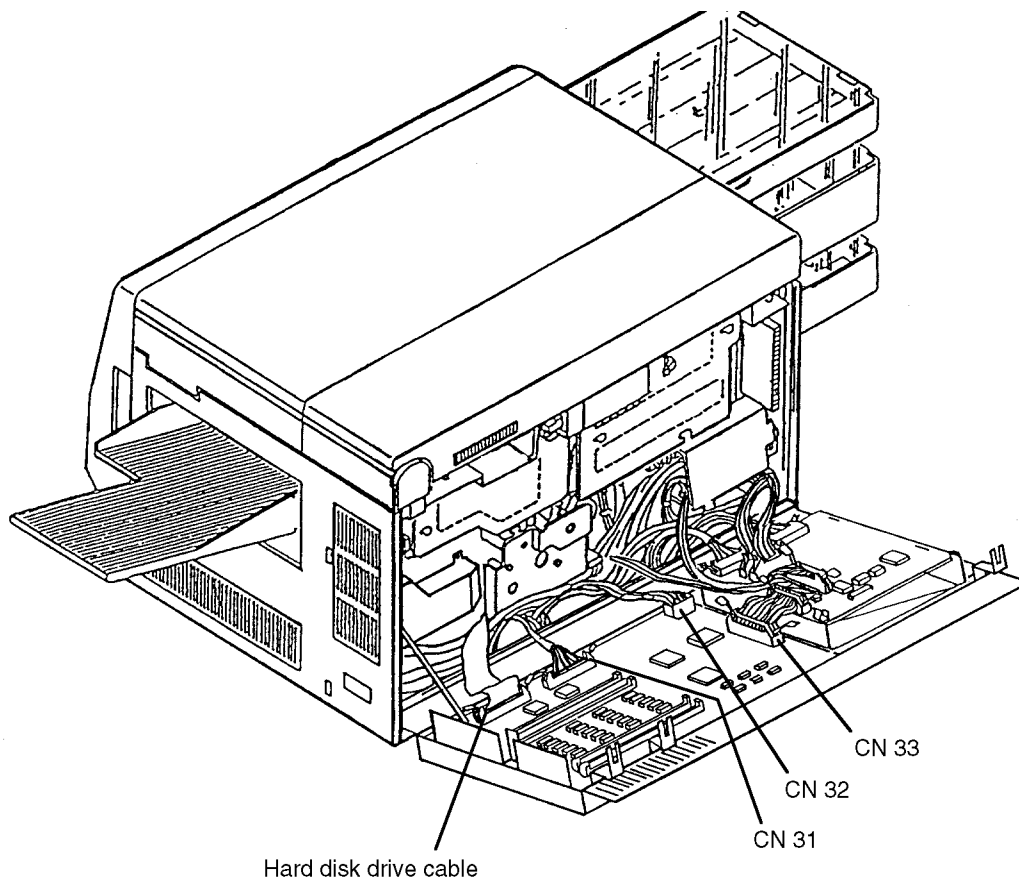

VPCL Board Removal

- 1 Open the back cover.
- 2 Disconnect CN34, CN36, CN37, CN40, CN41, CN400, and CN91.
- 3 Push the two retaining clips away from the board.
- 4 Remove the VPCL board.

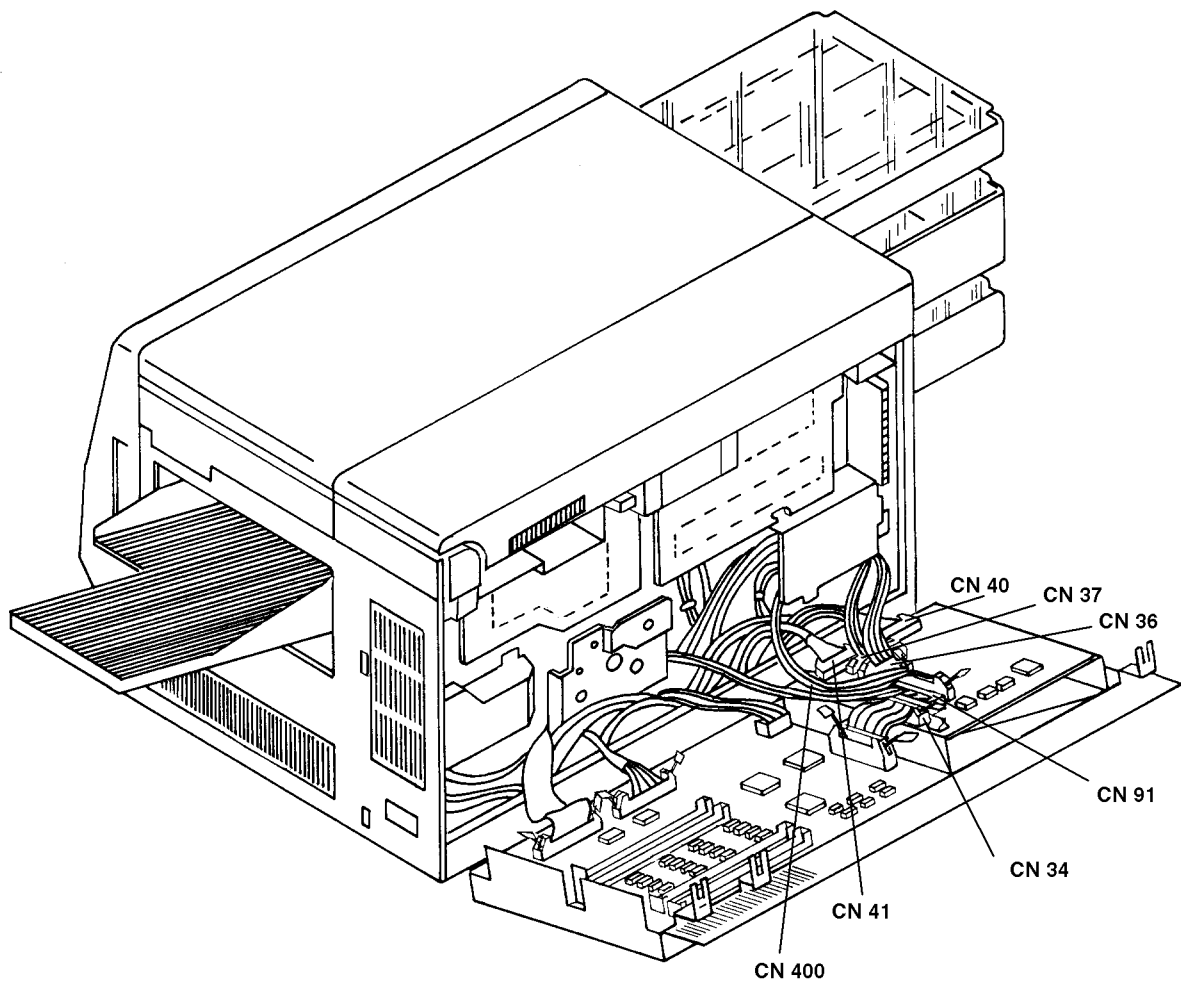

Printhead Assembly Removal

- 1 Open the front, top, and back covers.
- 2 Remove the photoconductor and place in its protective packaging.
- 3 Remove the cleaner.
- 4 Remove the fuser drive cover (three screws).
- 5 Remove the main drive cover (one screw).
- 6 Remove the gear stay cover (one screw).
- 7 Remove the gear stay (three screws).
- 8 Disconnect CN27, CN30, and CN96 (see back detail).
- 9 Remove the two back screws holding the printhead assembly in place.

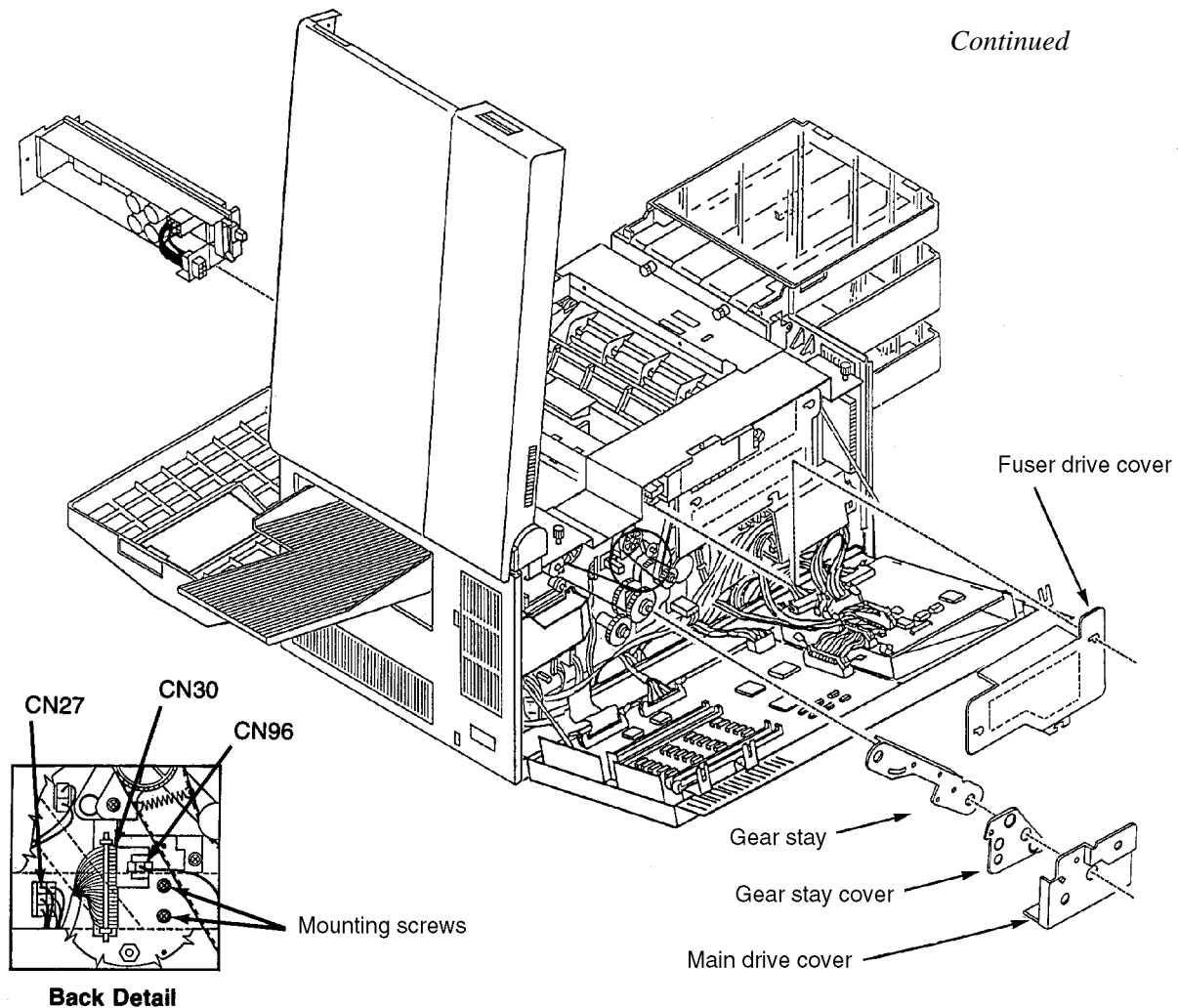

Printhead Assembly Removal

- 10 Remove the two front screws holding the printhead assembly in place.
- 11 Pull the printhead assembly from the front of the printer.

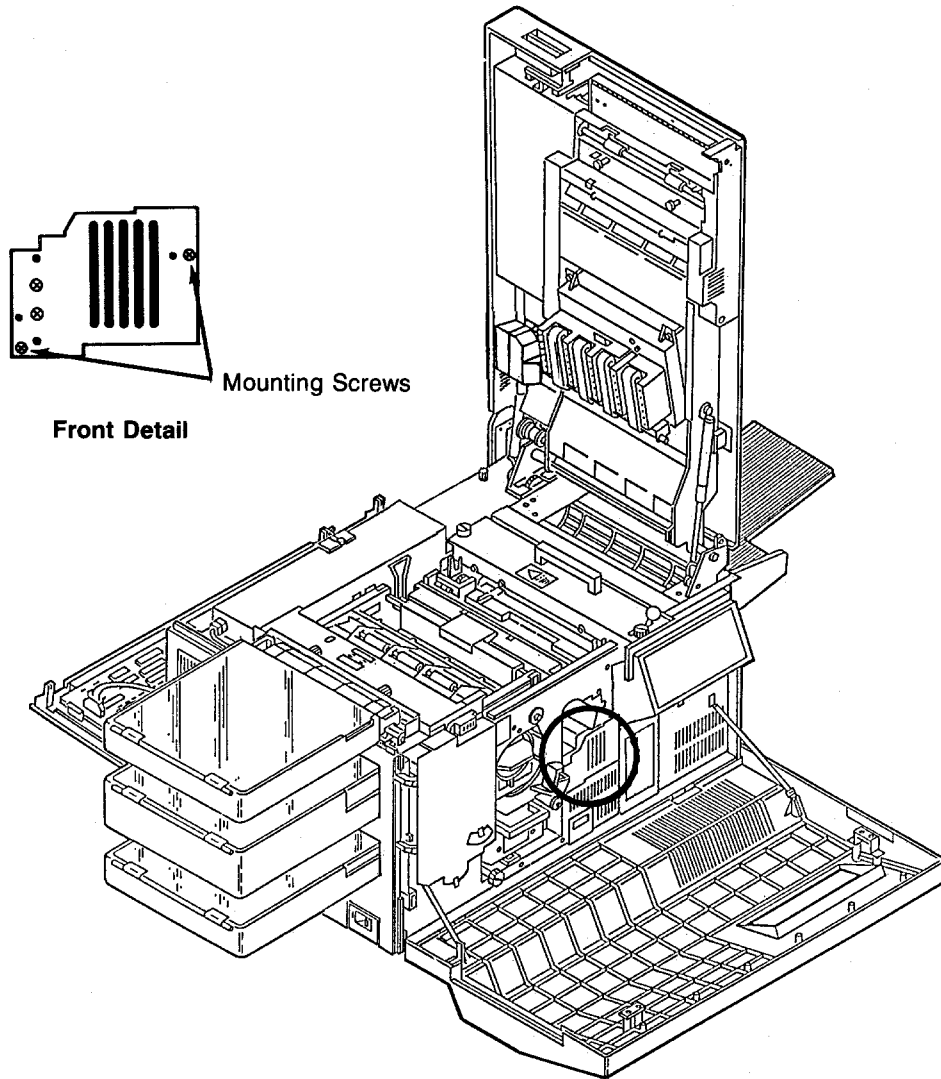

Printhead Circuit Board (ARIF) Removal

- 1 Remove ribbon connector J28 and plug P29 from the ARIF PCA.
- 2 Remove the screw securing the ARIF PCA to the printhead assembly.
- 3 Separate the ARIF PCA from the printhead assembly.

Note: If you are installing a new ARIF PCA, check the settings of DIP switch U1. The switches should be set to: ON - 1,2,3,5; OFF -4:

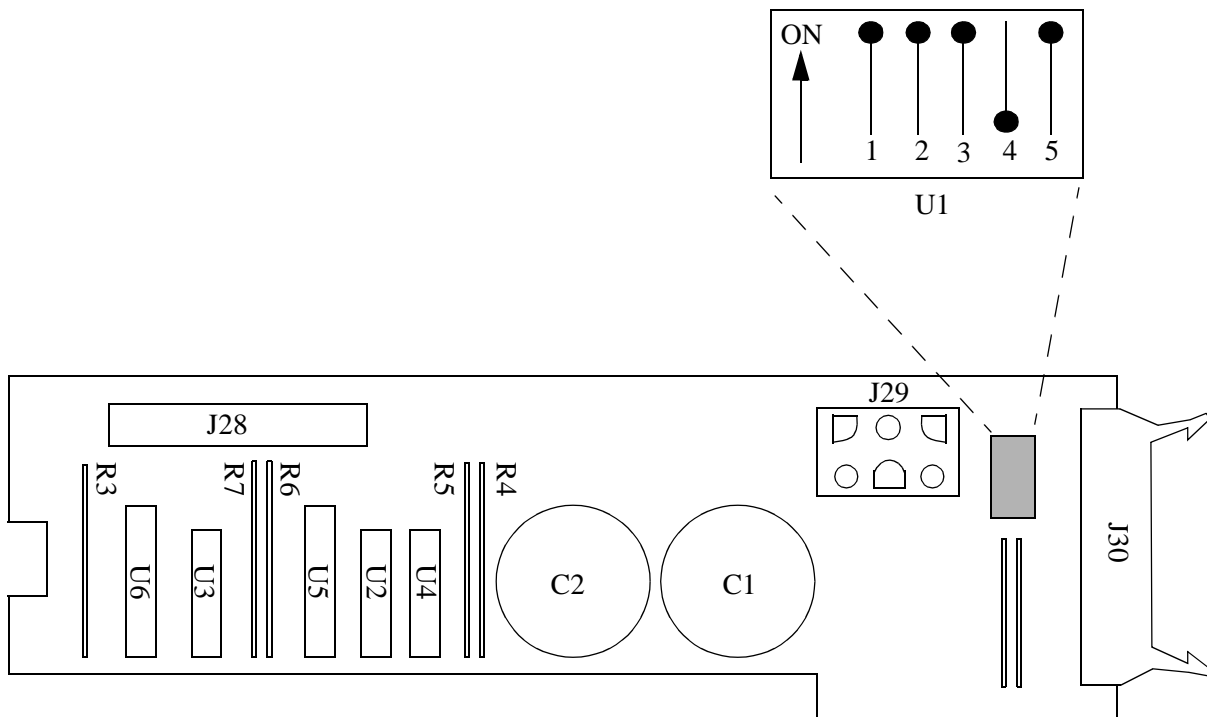

Hard Disk Drive Housing Removal

- 1 Open the front and back covers.
- 2 Disconnect CN77 and CN79.
- 3 Disconnect the hard drive's data cable at the RIGs board.
- 4 Loosen the thumbscrew on the back of the disk drive housing.
- 5 Remove the disk drive housing from the front of the printer.

Note: Use caution to avoid damaging the hard disk drive ribbon data cable.

Replacement Note:

For floppy drives, set the jumper on the drive circuit board to 0.

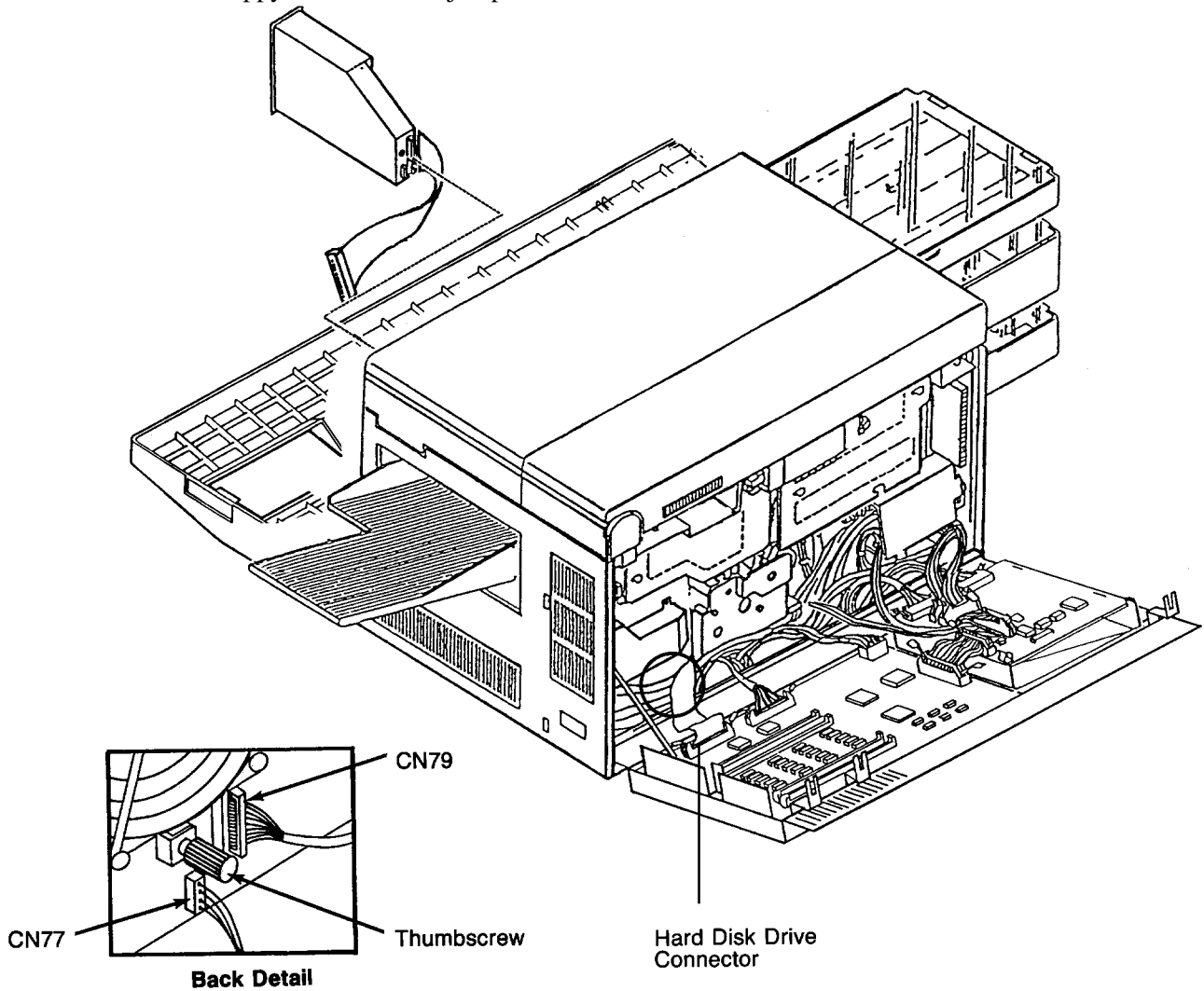

Floppy and Hard Disk Drive Removal

Note: The edges of the drive casing may be rough. Avoid contact with these surfaces.

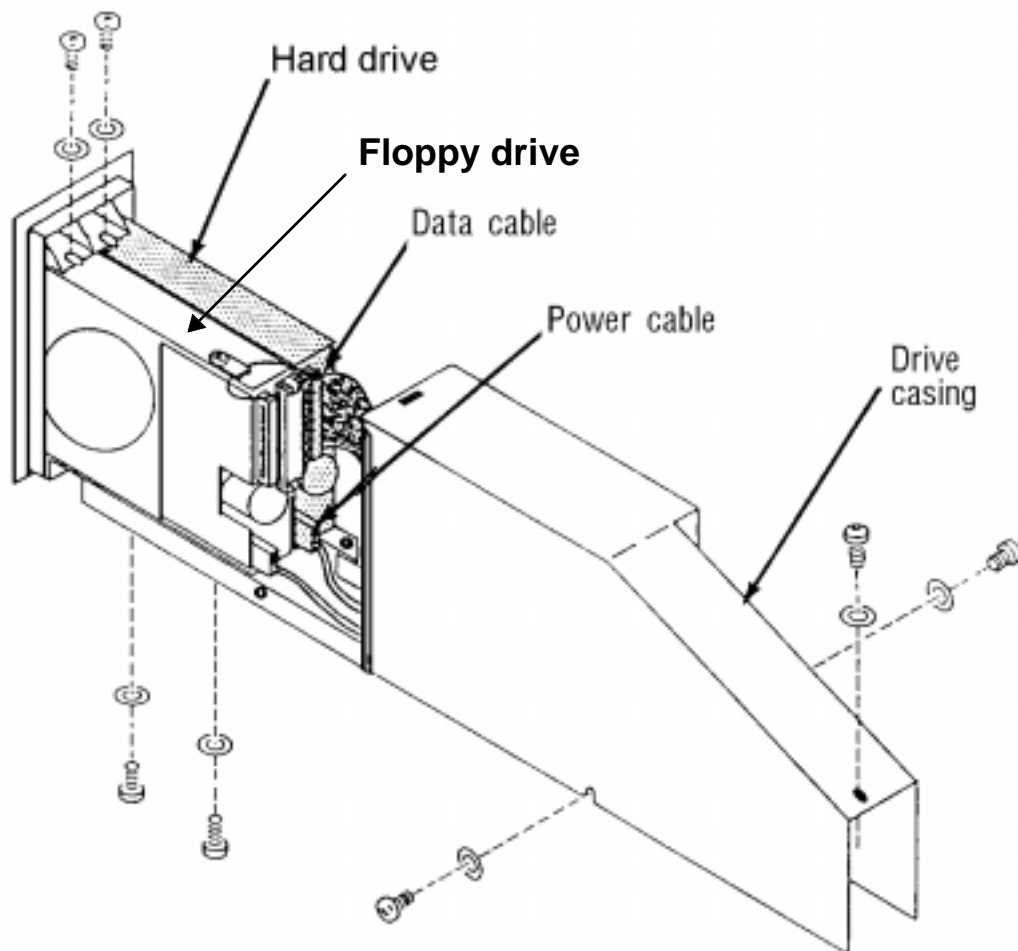

- 1** Remove the casing that surrounds the floppy disk and the hard disk drives.
 - Loosen the screws located on the casing, one on each side.
 - Remove the screw at the top rear of the casing.
 - Lift the casing up and away from the drive. Set it aside in a safe place.
- 2** Disconnect the power cable from the drive.
- 3** Disconnect the data cable from the drive.
- 4** Remove the screws holding the drive in place. Each drive is secured to the frame by one screw on the top and two screws on the bottom.
- 5** Pull the drive forward to free it from the drive frame.

Cooling Fan Removal

- 1 Open the back cover.
- 2 Remove the fuser drive cover (three screws).
- 3 Remove the cooling fan's two cover screws. Remove cover.
- 4 Disconnect CN21.
- 5 Remove the cooling fan (two screws).

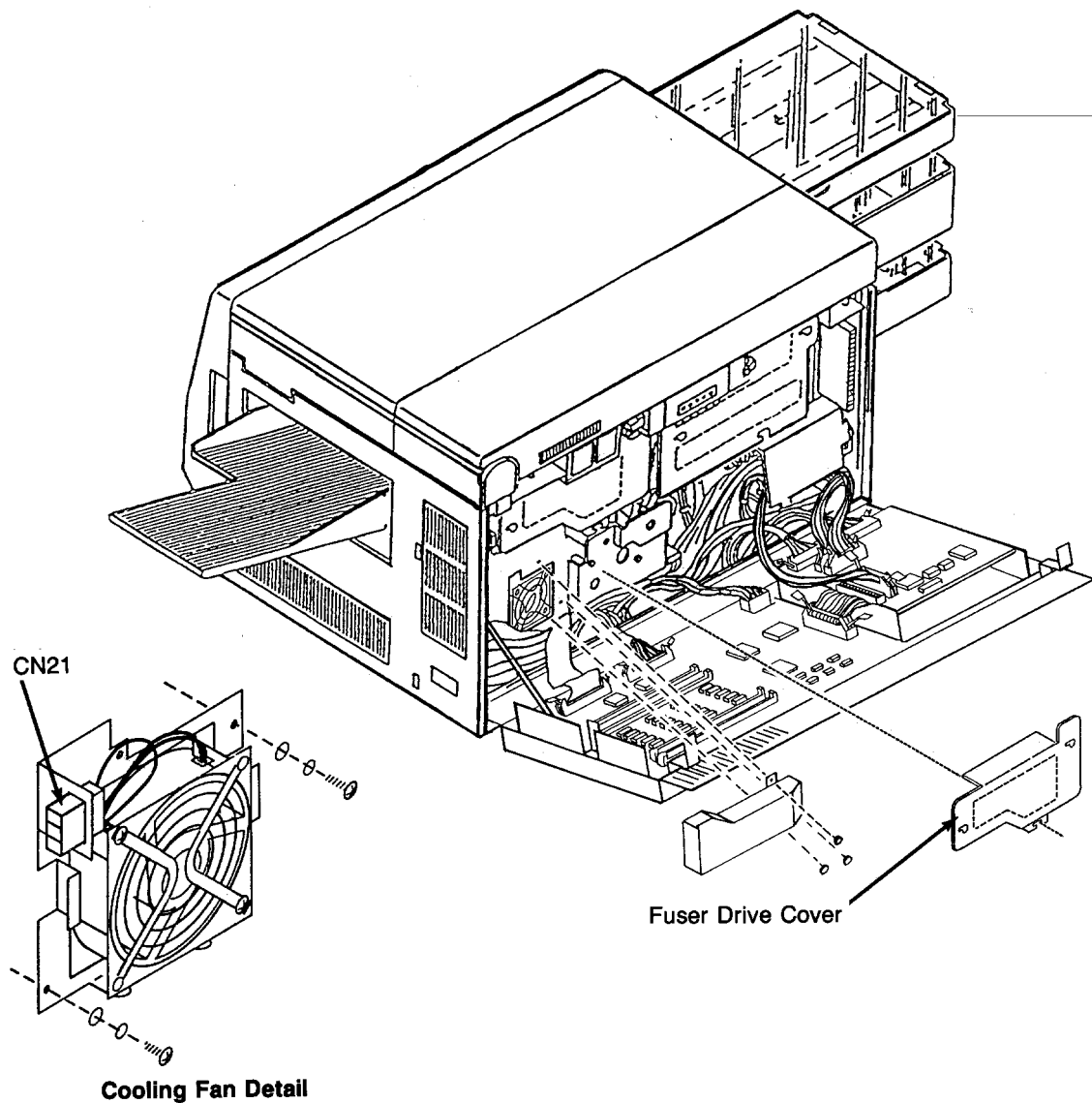

Toner Motor Removal

Toner Motor Removal

- 1 Open the back cover.
- 2 Disconnect CN18.
- 3 Remove the toner motor (three screws).

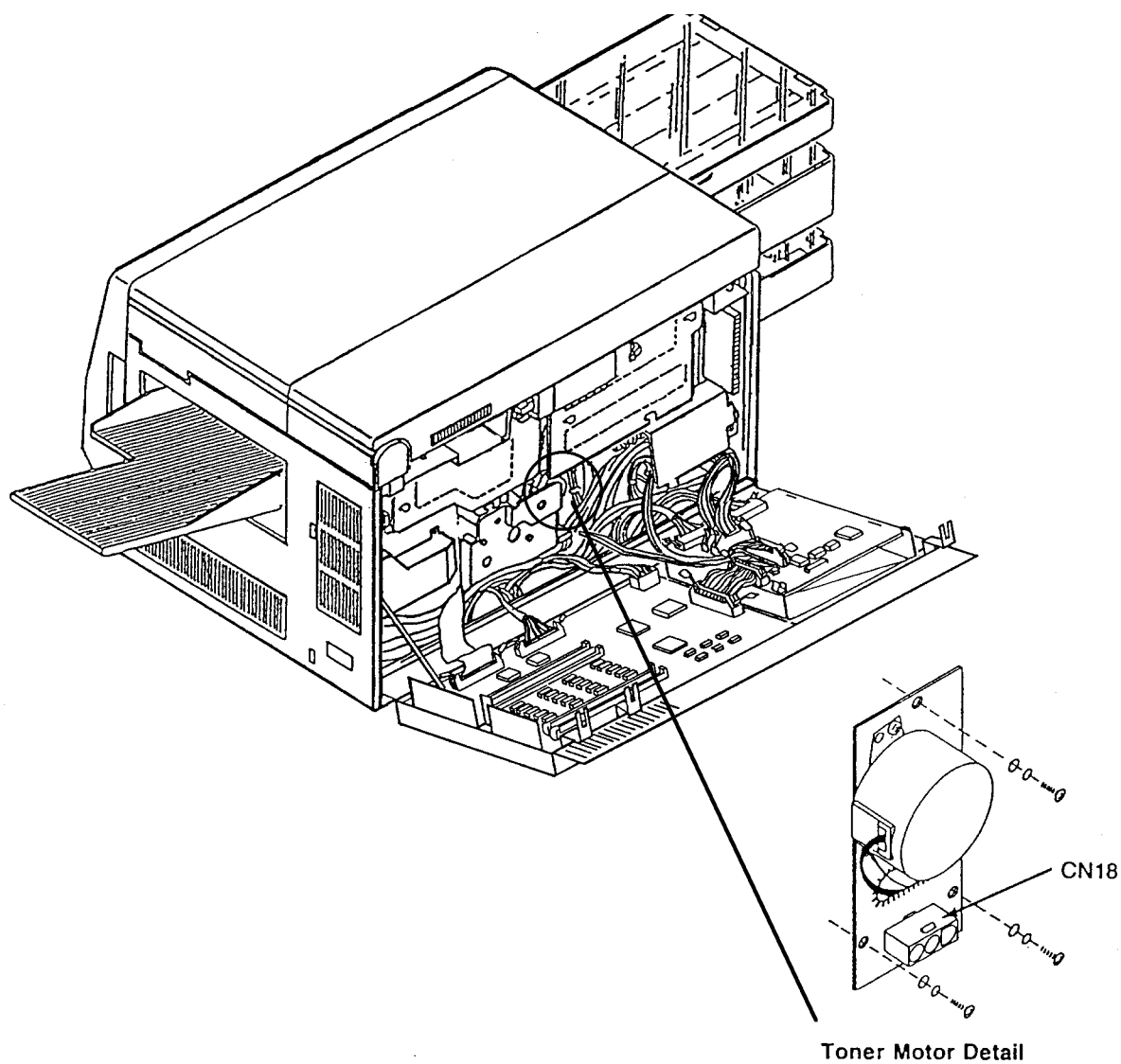

This space left blank intentionally.

AC Power Supply Removal

- 1 Open the front, back, and top covers.
- 2 Remove the duplex tray.
- 3 Remove the upper and lower paper cassettes.
- 4 Remove the left side cover. (See [page 7-7.](#))
- 5 Remove the paper feed drive cover (three screws).
- 6 Remove the power control board cover (one screw).
- 7 Disconnect CN4 and CN70.

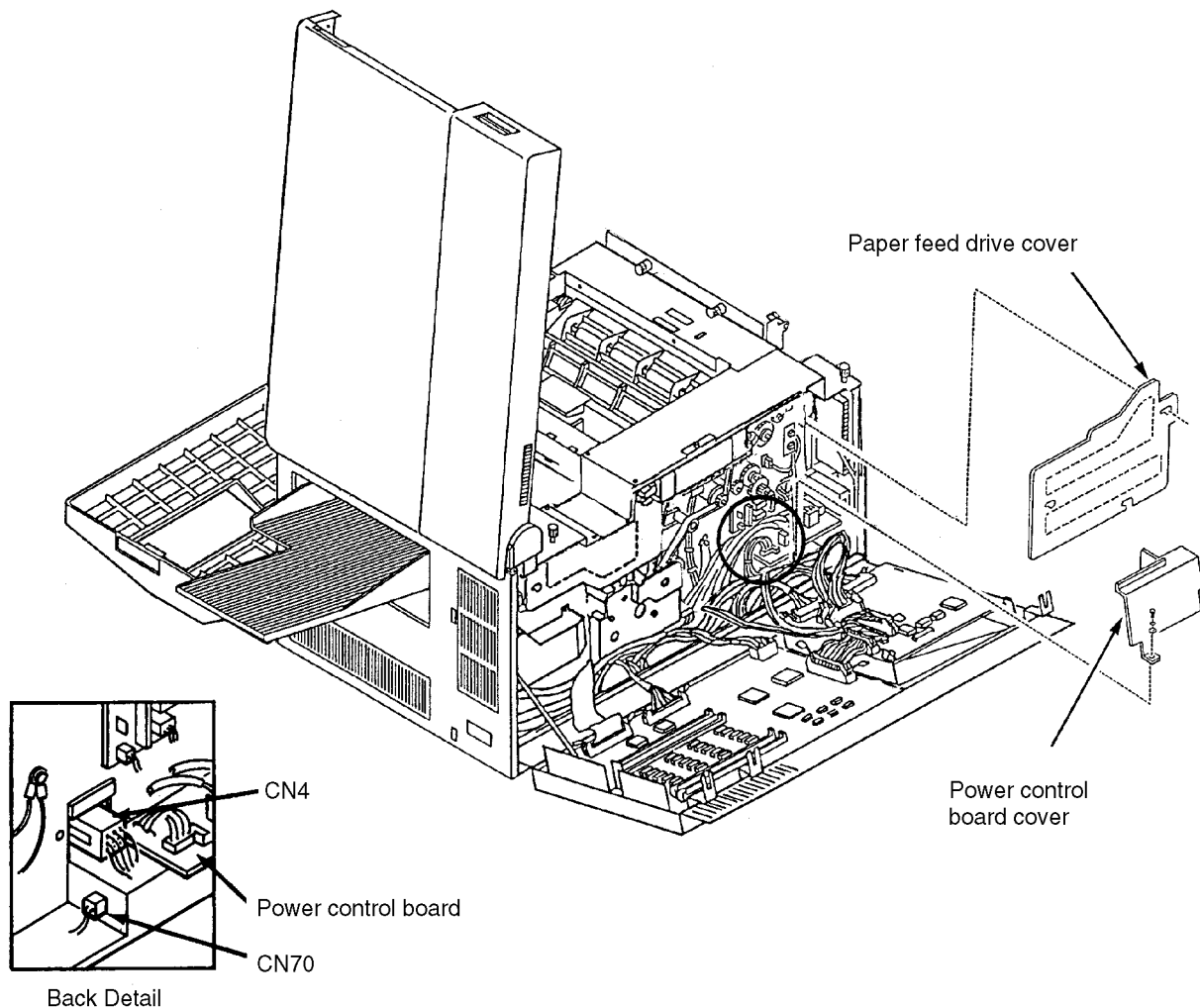

- 8 From the side of the printer, remove the three screws holding the AC power supply in place.
- 9 Slide the AC power supply out the side of the printer.
- 10 Verify that the Voltage Strapping Plug P1 is configured correctly and inserted in the power supply. (Refer to the illustration on [page 7-25](#))

AC Power Supply Removal

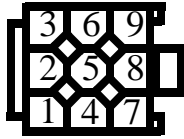

| Voltage | Jumper |
|---------|--------|
| 100 V | 1-3 |
| 120 V | 1-4 |
| 200 V | 1-5 |
| 220 V | 1-6 |
| 230 V | 1-7 |
| 240 V | 1-8 |

Voltage Strapping Plug P1

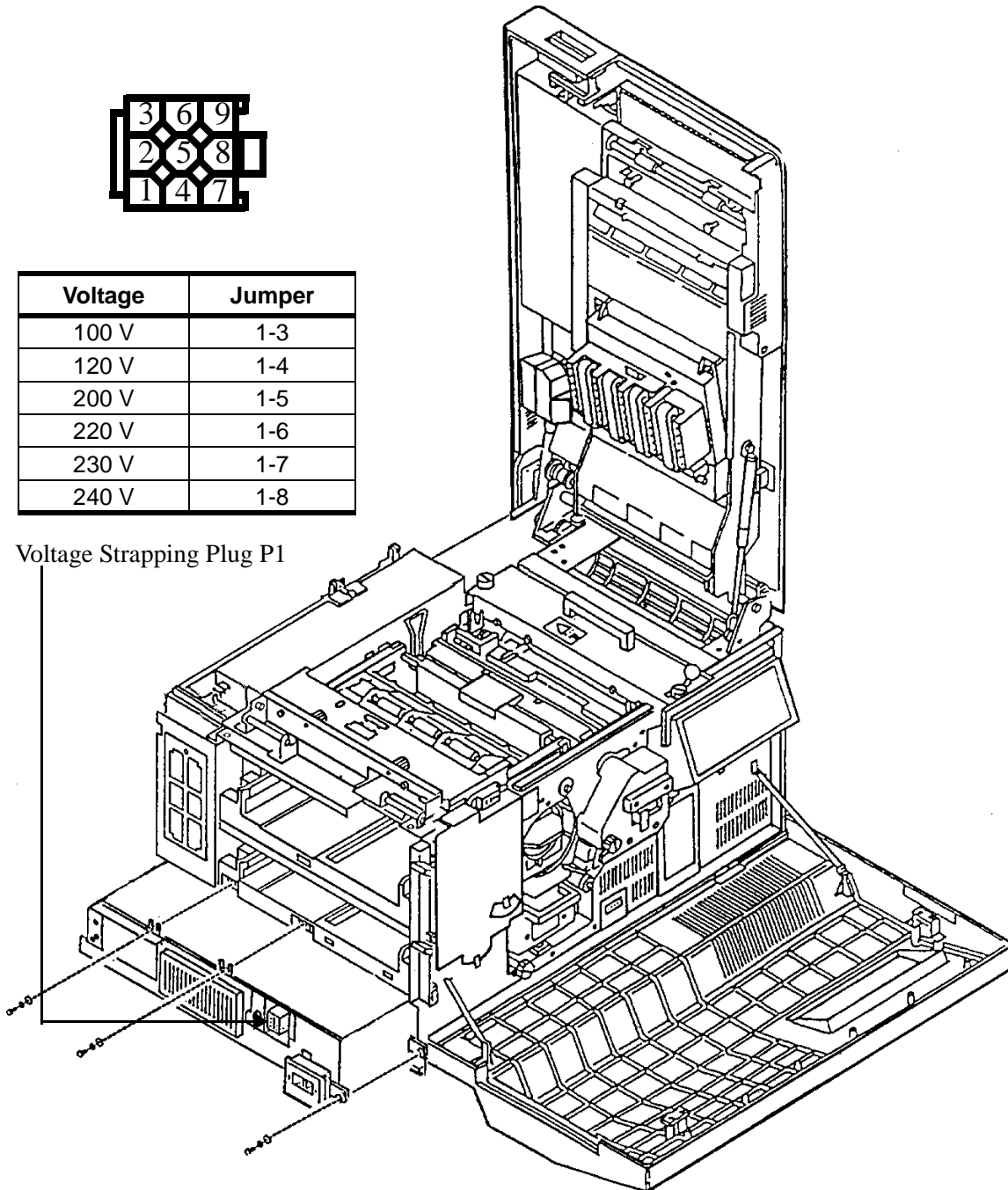

DC Power Supply Removal

- 1 Open the front, top and back covers.
- 2 Remove the cooling fan cover (two screws).
- 3 Disconnect CN6, CN7, CN8, and CN330.
- 4 Remove the output tray.
- 5 Remove the right side cover. (See [page 7-8.](#))
- 6 Remove the bracket for the output tray guide (two screws).
- 7 Remove the DC power supply (two screws).

Replacement Note:

When replacing the output tray bracket, make sure it is seated inside the DC power supply.

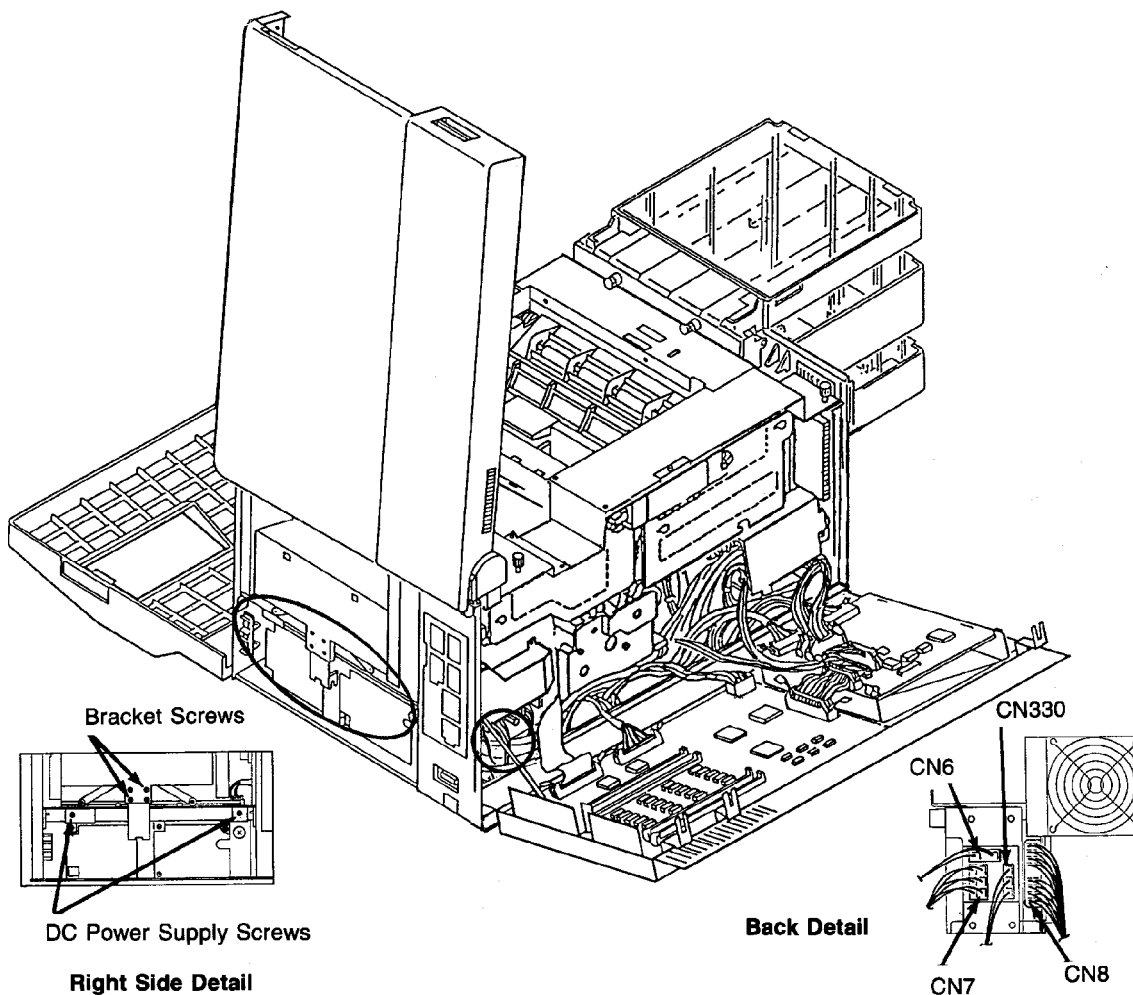

High Voltage Unit Removal

- 1 Open the top and back covers.
- 2 Remove the EMI grounding plate from the rear of the printer (four screws).
- 3 From the top, loosen the screw holding the high voltage power supply in place.
- 4 Pull the high voltage power supply out from the back of the printer.
- 5 Disconnect CN23, CN85, and the two high voltage leads.
- 6 Remove the high voltage power supply .

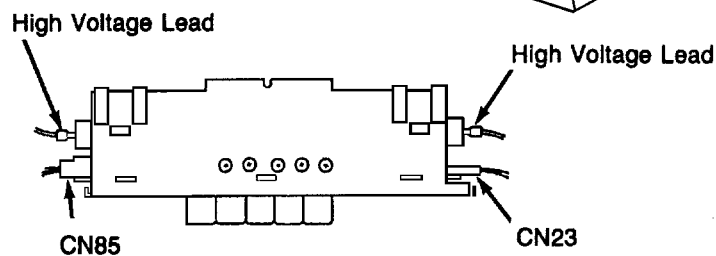
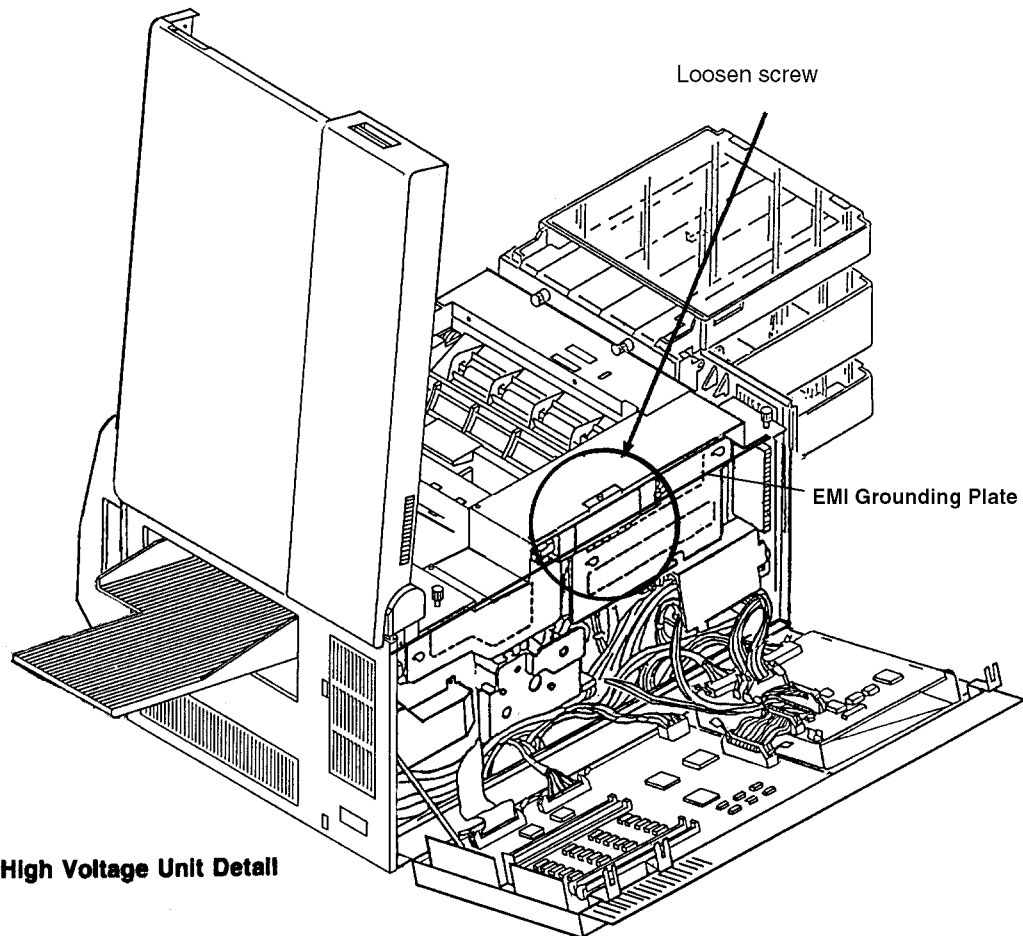

Photoconductor Seam Sensor Removal

- 1 Open the front, back, and top covers.
- 2 Remove the photoconductor and place in its protective packaging.
- 3 Remove the developer.
- 4 Remove the paper feed drive cover (three screws).
- 5 Remove the bracket holding CN64 in place (one screw).
- 6 Remove the screw holding the seam sensor bracket in place. It is situated under the bracket for CN64.

Continued

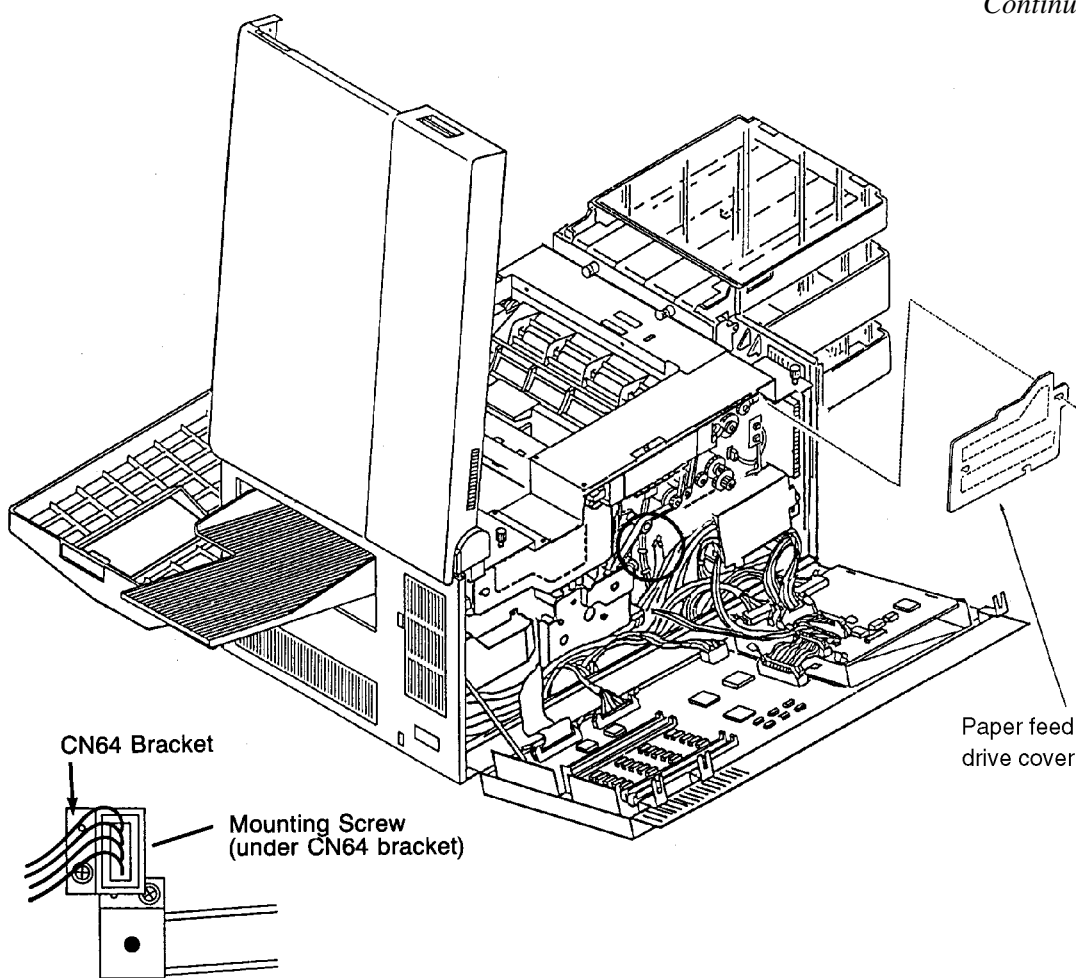

Back Detail

- 7 From inside the empty photoconductor cavity, disconnect CN63.
- 8 Lift the photoconductor seam sensor and bracket up out of the printer, as shown in the illustration on [page 7-29](#).

Note: Use caution to avoid bending the bracket.

Seam Sensor and Bracket

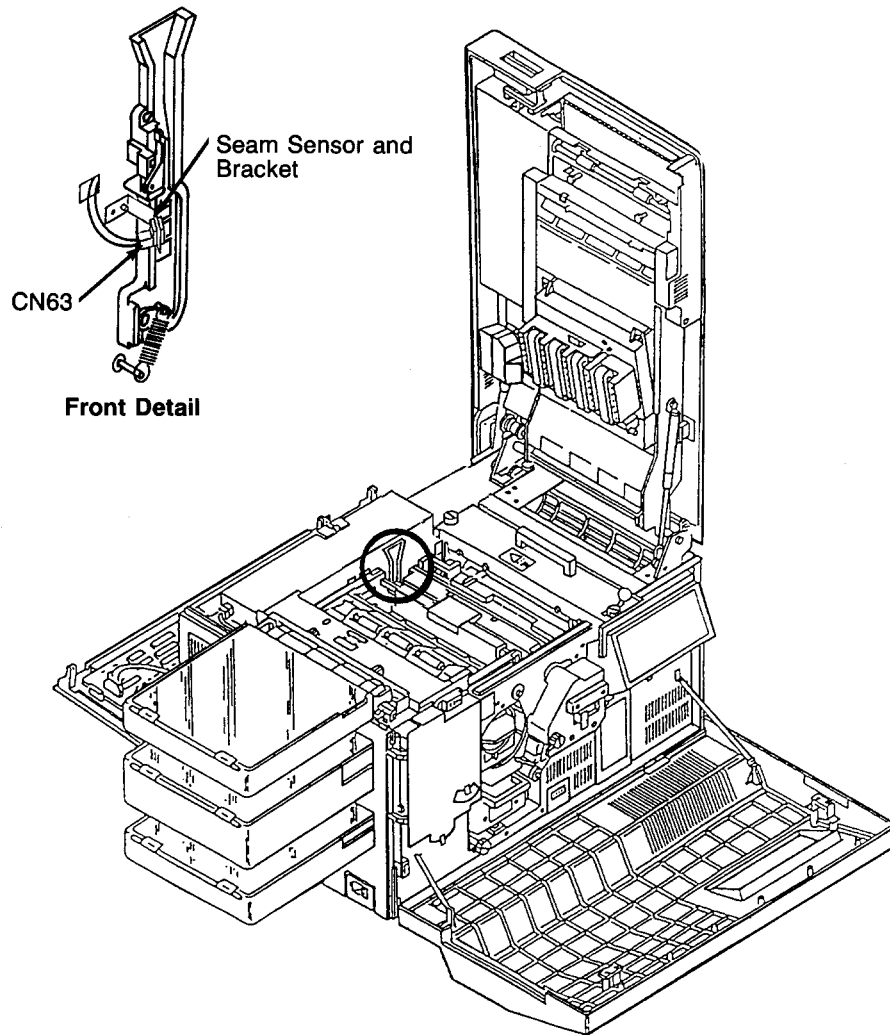

Photoconductor Rear Guide Rail Removal

- 1 Open the front, back, and top covers.
- 2 Remove the photoconductor and place in its protective packaging.
- 3 Remove the developer.
- 4 Remove the paper feed drive cover (three screws).
- 5 Remove the photoconductor seam sensor. (See [page 7-28.](#))
- 6 Remove the spring at the base of the guide rail. To do this, gently pull the spring forward off its post.
- 7 Disconnect C64.
- 8 Remove the ground screw.

- 9 Remove CN64 from its bracket.

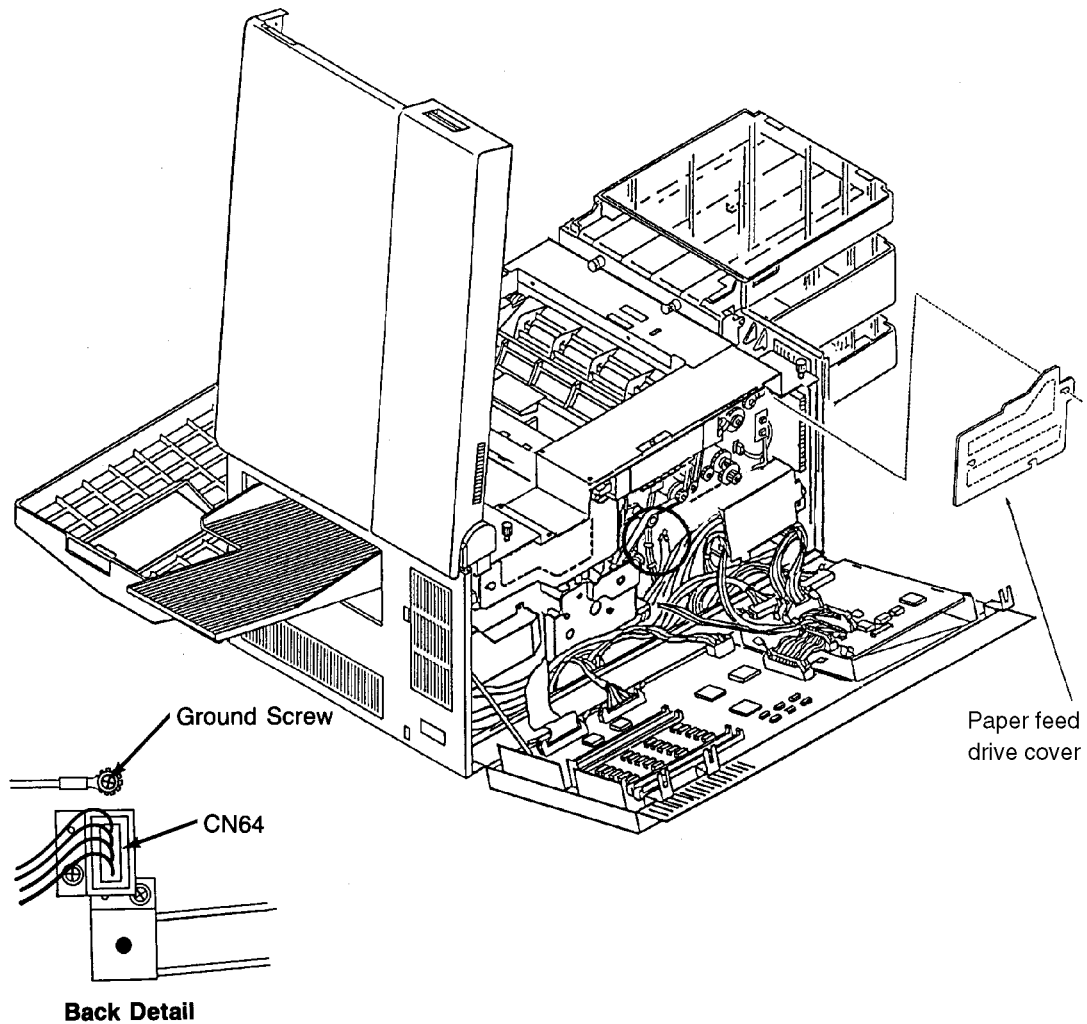

- 10 From inside the photoconductor cavity, remove the two screws holding the guide rail in place.
- 11 Push CN64 and the ground wire through the photoconductor cavity to the front of the printer.

Photoconductor Rear Guide Rail Removal

- 12 Lift the photoconductor guide rail from the printer.

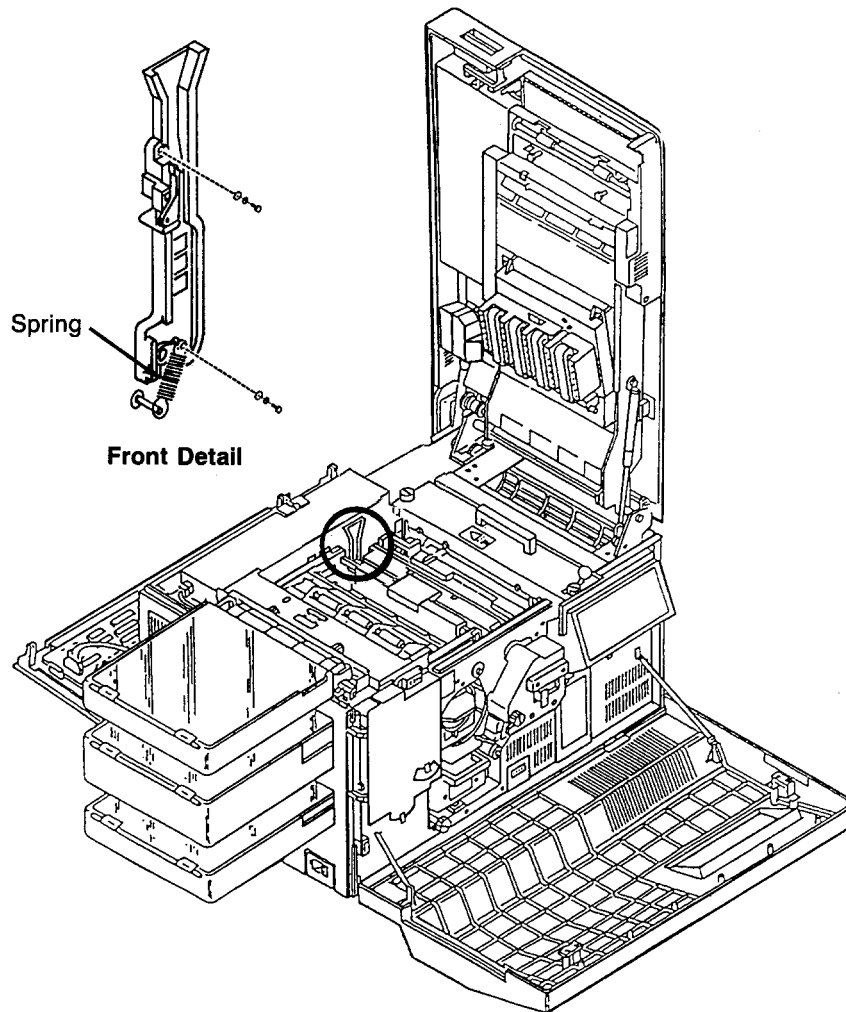

Power Control Board Removal

- 1 Open the back cover.
- 2 Remove the paper feed drive cover (three screws).
- 3 Remove the power control board cover (one screw).
- 4 Disconnect CN9, CN10, CN11, CN12, CN13, and CN14.
- 5 Remove power control board (two screws).

Replacement Note:

Be sure that the back of the board is mounted properly in the frame slots.

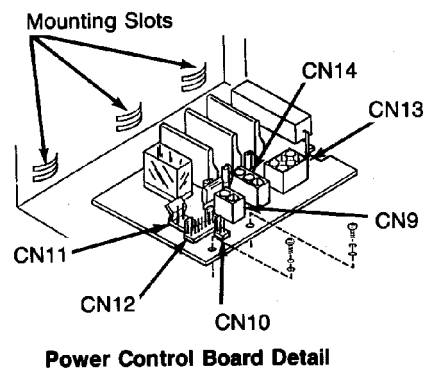
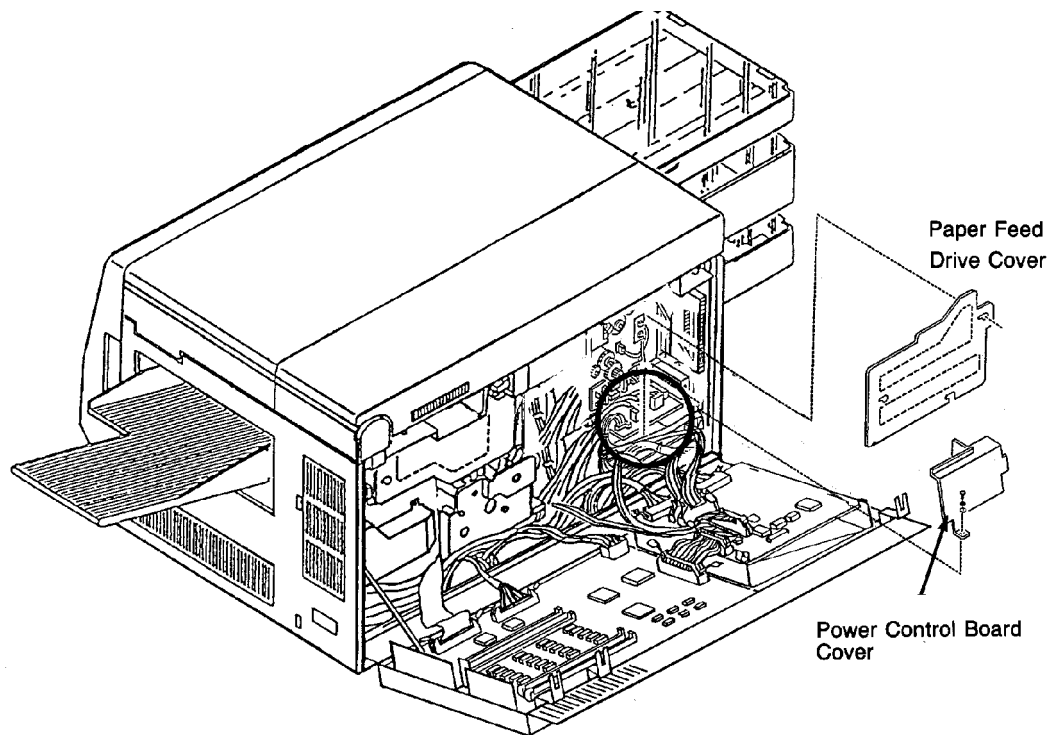

Upper or Lower Paper Size Sensor Removal

Upper or Lower Paper Size Sensor Removal

- 1 Remove the duplex tray.
- 2 Remove the upper and lower paper cassettes.
- 3 Using a small screwdriver, pry up the paper size sensor. Turn the sensor counterclockwise and lift up.
- 4 For the upper paper size sensor, disconnect CN45 and CN46.
- 5 For the lower paper size sensor, disconnect CN43, CN47, and CN48.

Note: Use caution not to break the cables.

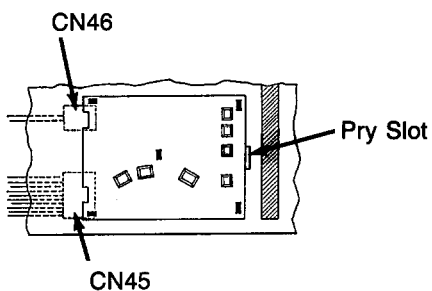
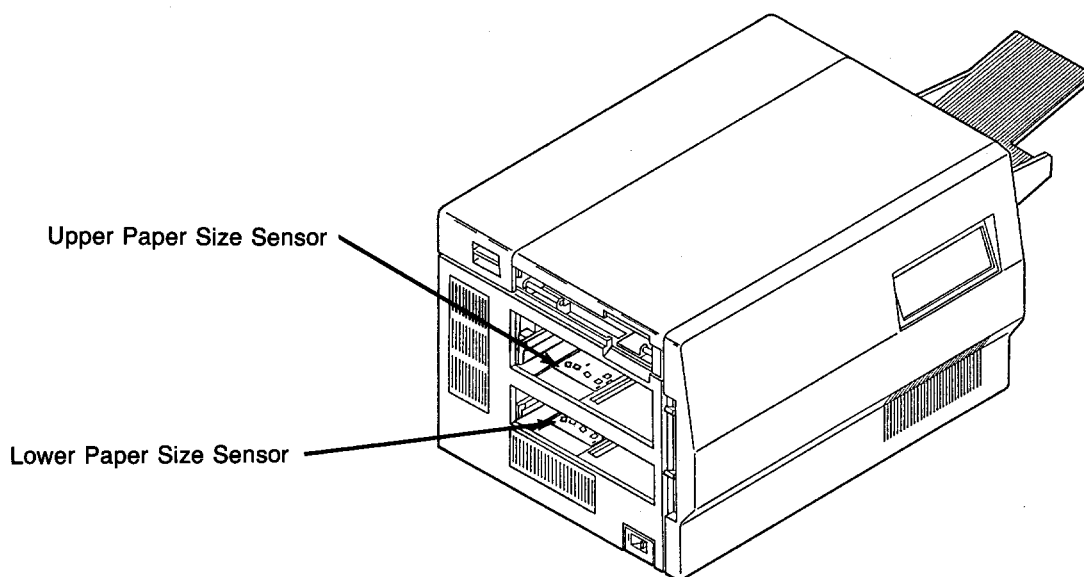

Upper Paper Size Sensor Detail

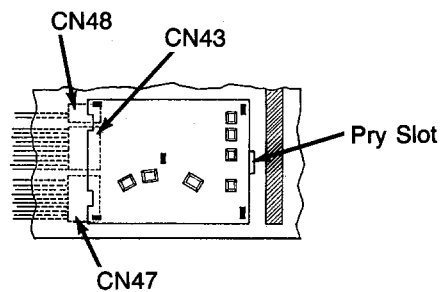

Lower Paper Size Sensor Detail

Upper Cassette Mount Removal

- 1** Open the front, back, and top covers.
- 2** Remove the duplex tray.
- 3** Remove the upper and lower paper cassettes.
- 4** Remove the left side cover. (See [page 7-7.](#))
- 5** Remove the paper feed drive cover (three screws).
- 6** Remove the power control board cover (one screw).
- 7** From the back, remove the two screws holding the upper cassette mount in place.
- 8** Loosen the CN62 jack and pull it to the back of the printer.

Upper Cassette Mount Removal

9 Disconnect CN62.

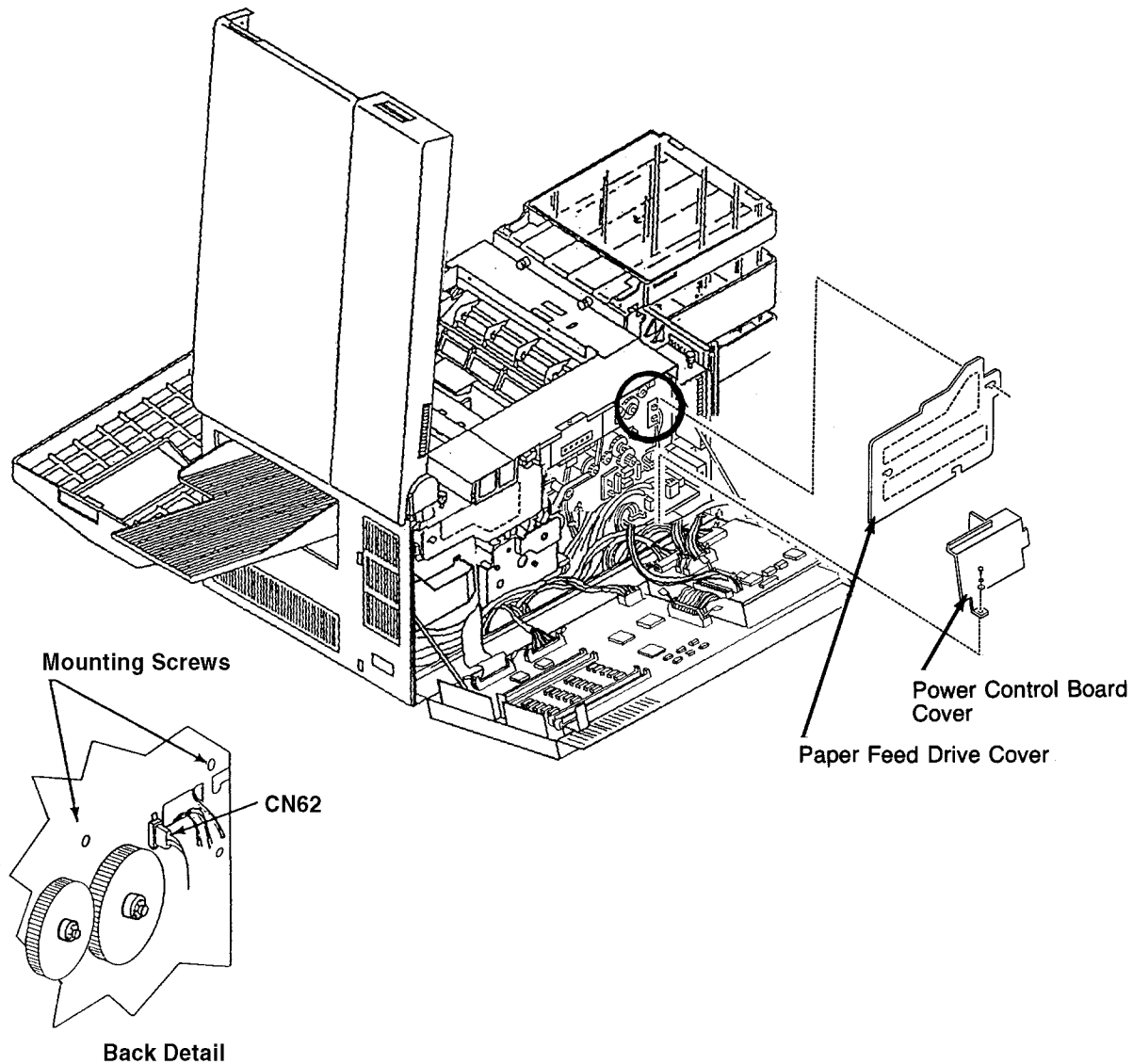

10 Remove the upper paper size sensor.

11 Remove the cassette release cover (two screws).

12 Remove the plastic guide on the vertical edge of the printer. Depress the tabs visible through the cassette housing. Gently turn it and lift from the printer.

13 For the tray releases:

- Carefully release the tension spring cable from the pick pressure adjustment lever.
- Remove the spring and cable.
- Remove the upper and lower levers (one spring and C-clip each).
- Remove the upper and lower cams (one screw each).

- Remove the upper and lower latches (one spring and C-clip each).

(Continued on next page).

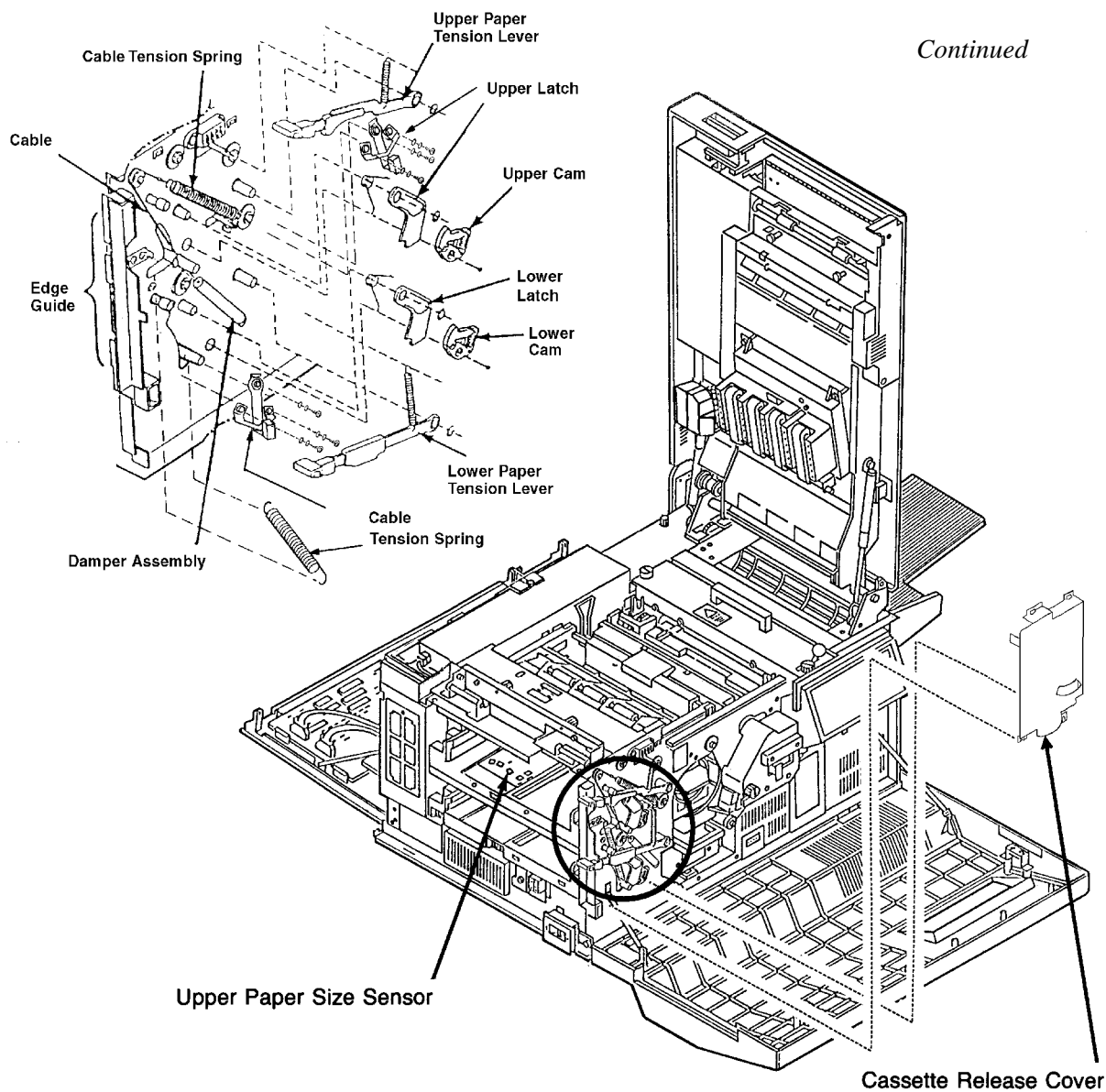

- 14** Disengage the top of the damper assembly. Push it to the right out of the way
- 15** Remove the lower bracket (four screws; two front and two back).
- 16** Remove the tray (four screws; two front and two back).
- 17** Remove the upper tray lift arm (two screws with two plastic retainers).
- 18** Remove the upper bracket (four screws; two front and two back).
- 19** Remove the screws holding the upper cassette mount in place (two front and 2 side).
- 20** Pull the upper cassette mount from its front and back mounting pins.

Upper Cassette Mount Removal

21 Rotate the upper cassette mount upwards and out of the printer.

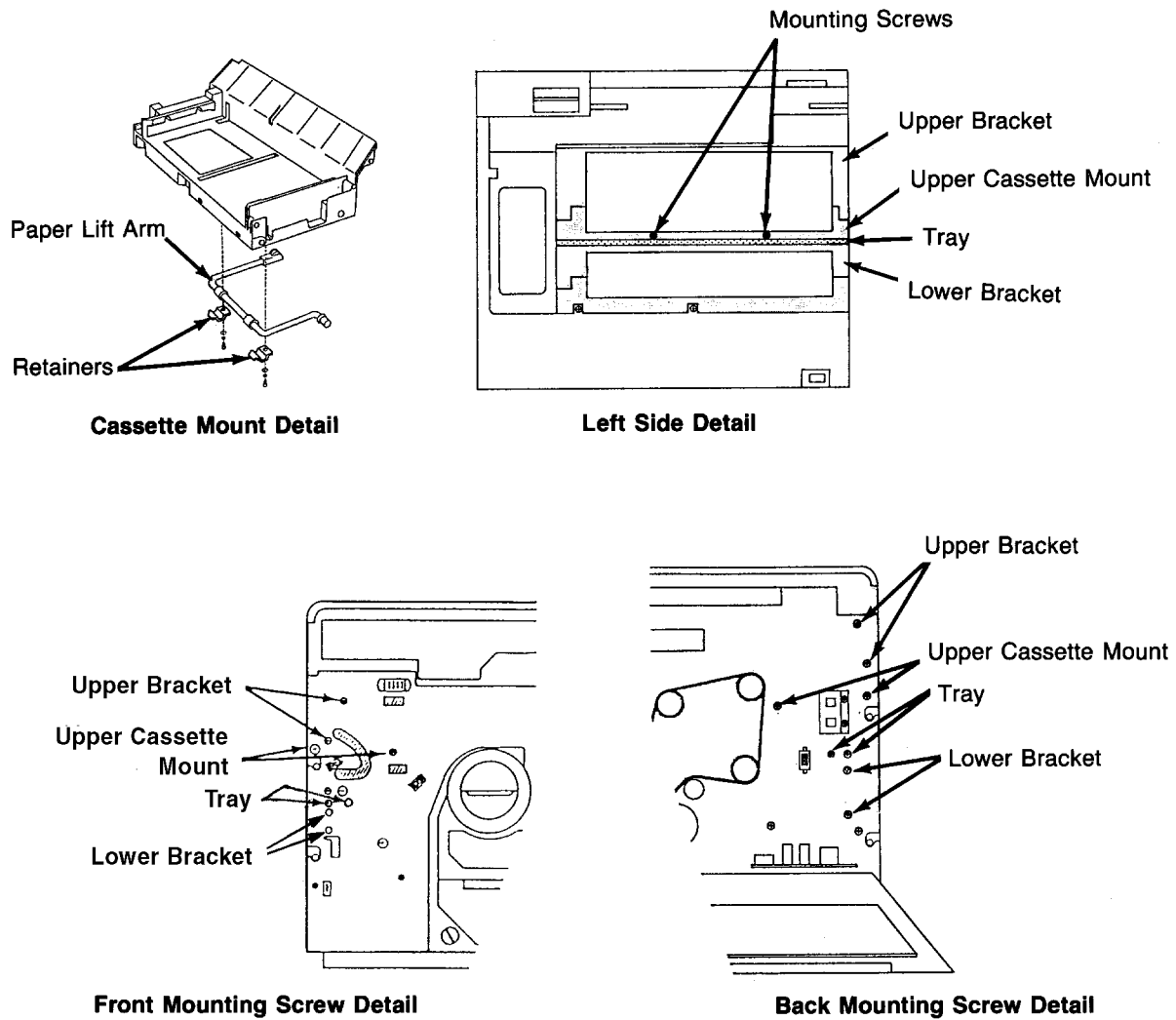

This space left blank intentionally.

Lower Cassette Mount Removal

- 1** Open the front, back, and top covers.
- 2** Remove the duplex tray.
- 3** Remove the upper and lower paper cassettes.
- 4** Remove the left side cover. (See [page 7-7.](#))
- 5** Remove the paper feed drive cover (three screws).
- 6** Remove the power control board cover (one screw).
- 7** Remove the power control board. (See [page 7-33.](#))

- 8 From the back, remove the two screws holding the lower cassette mount in place.

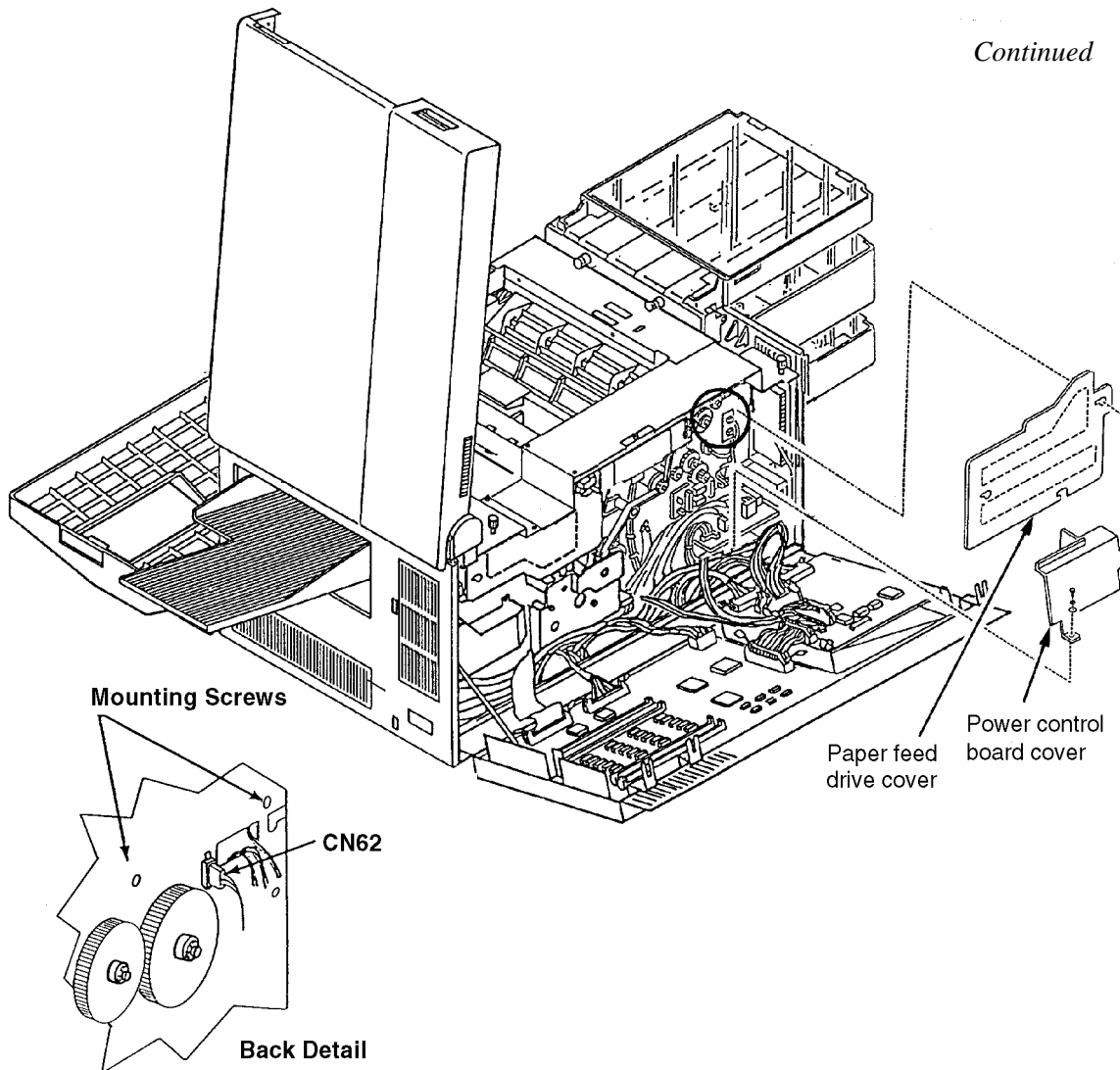

- 9 Remove the lower paper size sensor.
- 10 Remove the cassette release cover (two screws).
- 11 Remove the plastic guide on the vertical edge of the printer. Depress the tabs visible through the cassette housing. Gently turn it and lift from the printer.
- 12 For the lower tray release:
- Carefully release the tension spring cable from the pick pressure adjustment lever.
 - Remove the spring and cable.
 - Remove the lever (one spring and C-clip).

Lower Cassette Mount Removal

- Remove the cam (one screw).
- Remove the latch (one spring and C-clip).

Continued

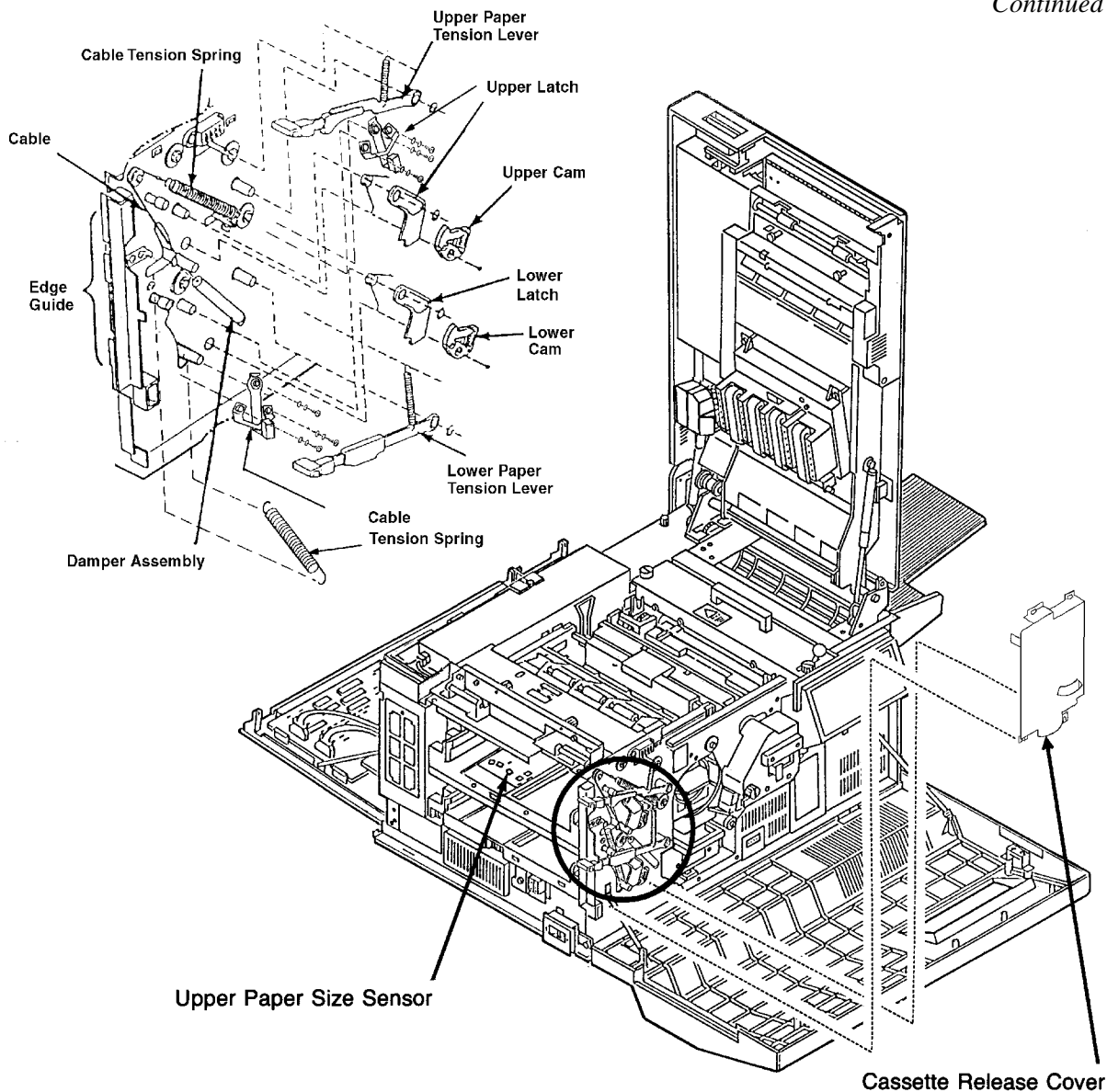

(Continued on next page)

- 13** Remove the lower bracket (four screws; two front and two back).
- 14** Remove the tray (four screws; two front and two back)
- 15** Remove the AC power supply. (See [page 7-23](#).)
- 16** Remove the lower tray lift arm (two screws with two plastic retainers).
- 17** Remove the screws holding the lower cassette mount in place (two front and 2 side).
- 18** Pull the lower cassette mount from its front and back mounting pins.

19 Rotate the lower cassette mount upwards and out of the printer

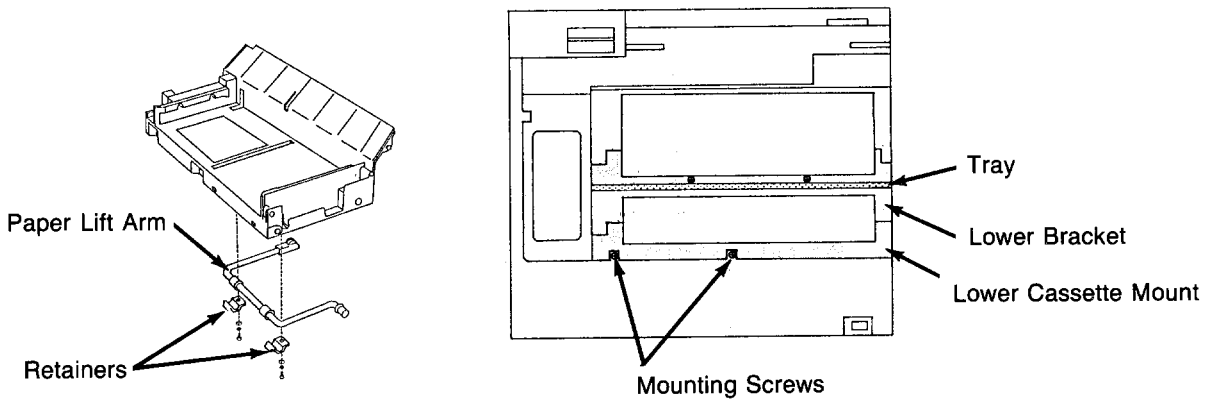

Left Side Detail

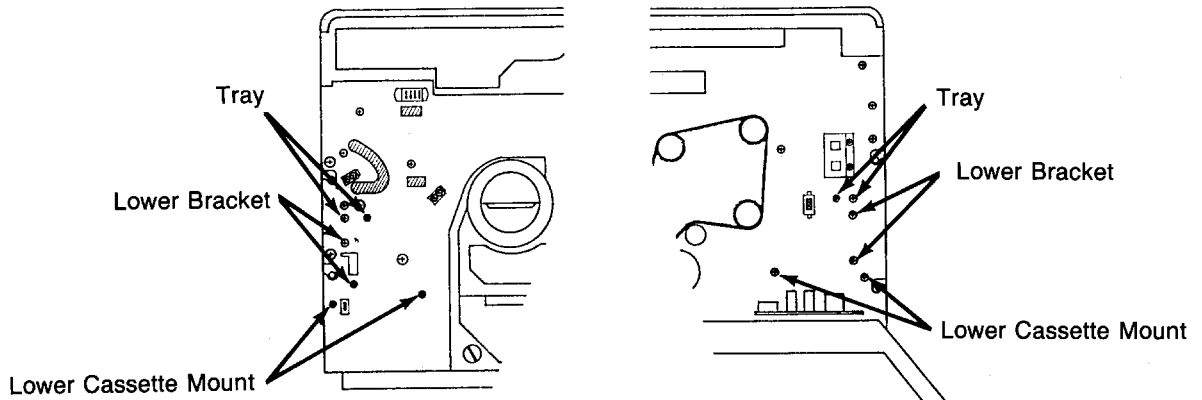

Front Mounting Screw Detail

Back Mounting Screw Detail

Lower Cassette Mount Removal

This space left blank intentionally.

Upper Paper Guide Removal

- 1 Open the front, back, and top covers.
- 2 Remove the EMI grounding plate from the rear of the printer (four screws).
- 3 Remove the paper feed drive cover (three screws).
- 4 Disconnect the transfer corona high voltage lead from the HVPS.
- 5 Disconnect the ground screw for the transfer corona.

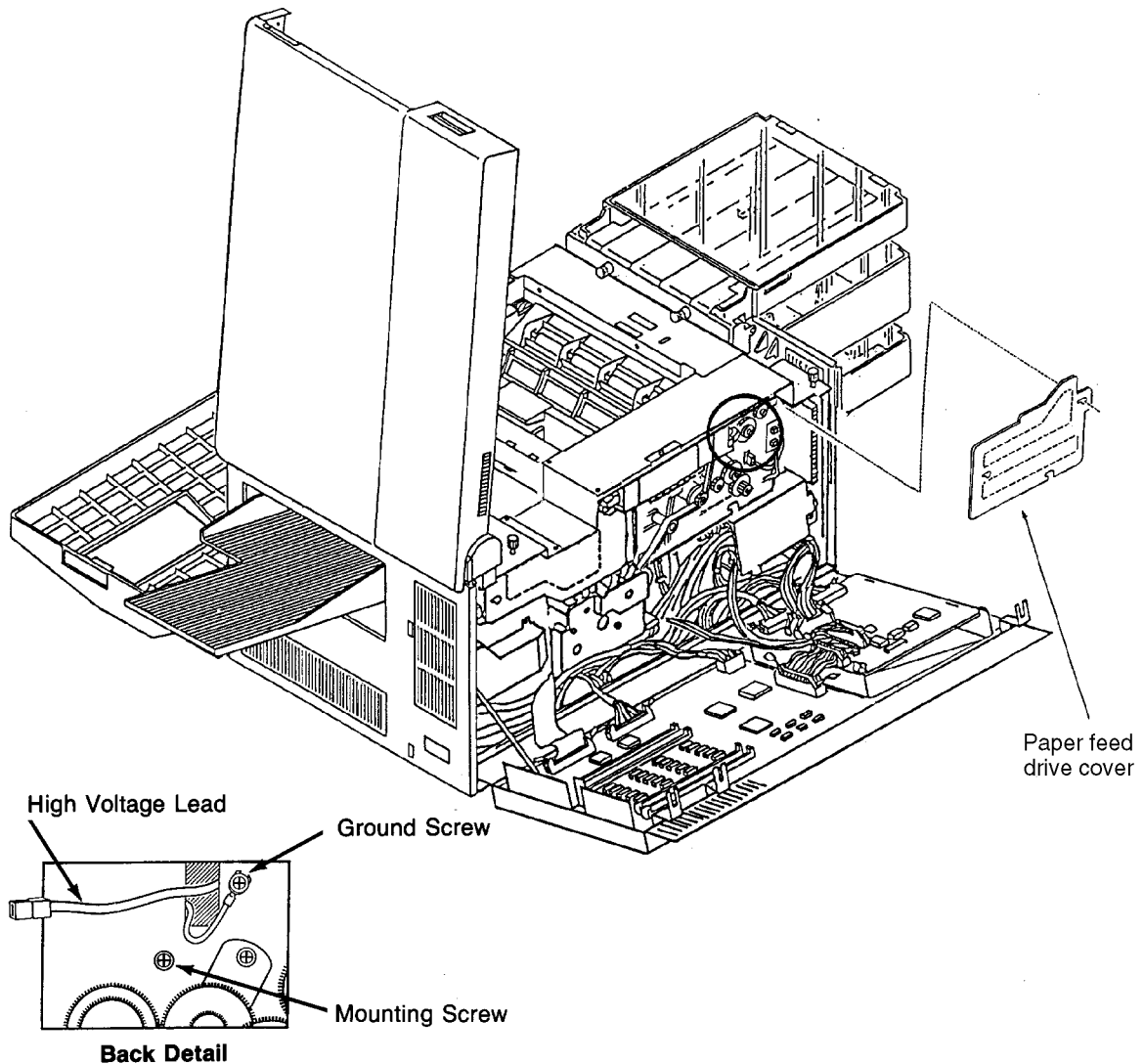

- 6 Remove the cassette release cover (two screws).
- 7 Raise the upper paper guide.
- 8 Remove the back screw holding the upper paper guide in place.
- 9 Remove the front screw holding the upper paper guide in place.
- 10 Release the two springs at the base of the upper paper guide.
- 11 Lift the upper paper guide out of the printer

Upper Paper Guide Removal

Upper Paper Guide Removal.

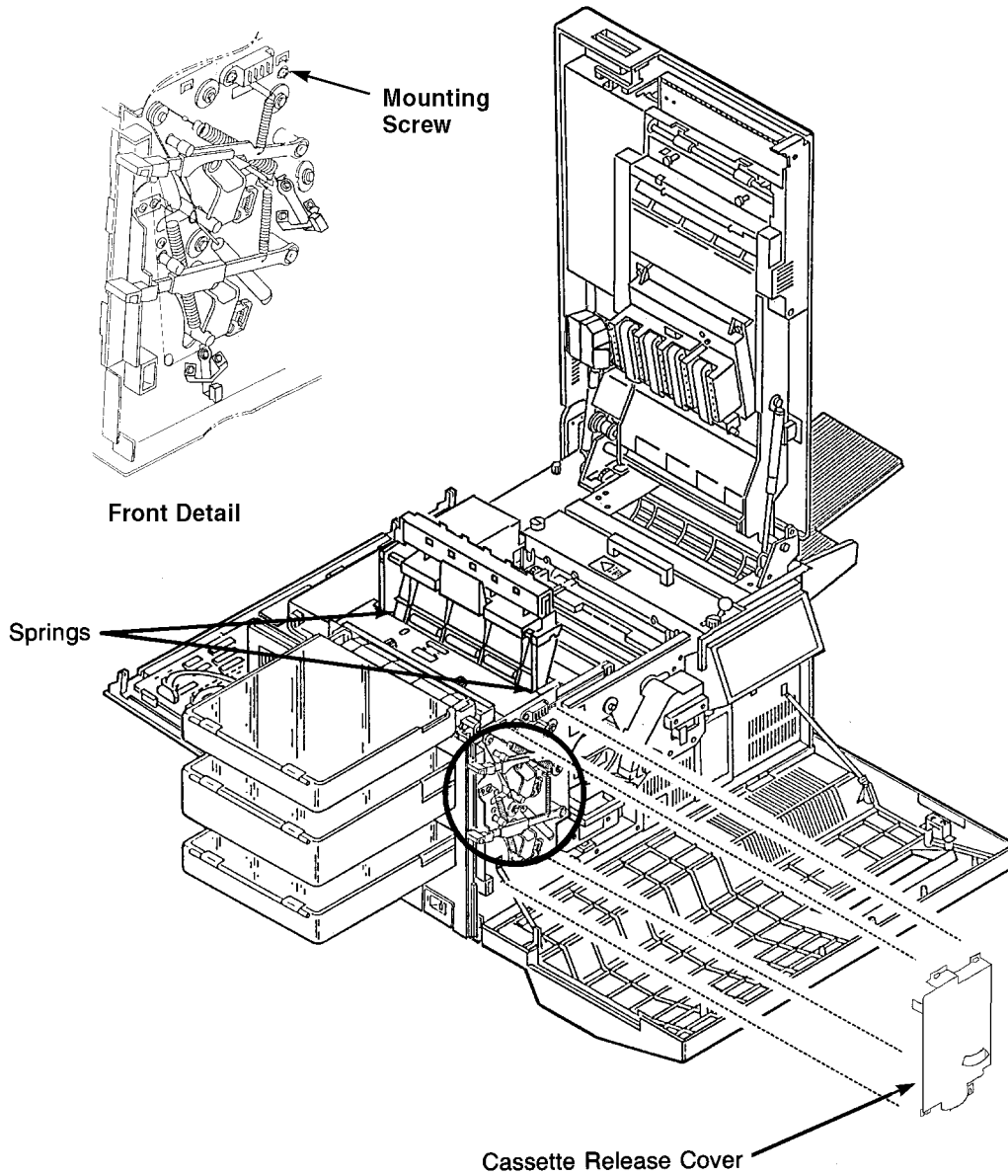

Upper Paper Guide Roller Removal

- 1 Open the top cover.
- 2 Remove the two springs at the ends of the roller. To do this, press down gently on the end of the spring and move it out from under the plastic.
- 3 Raise the upper paper guide.
- 4 Remove the roller and bearings from the underside of the upper paper guide.

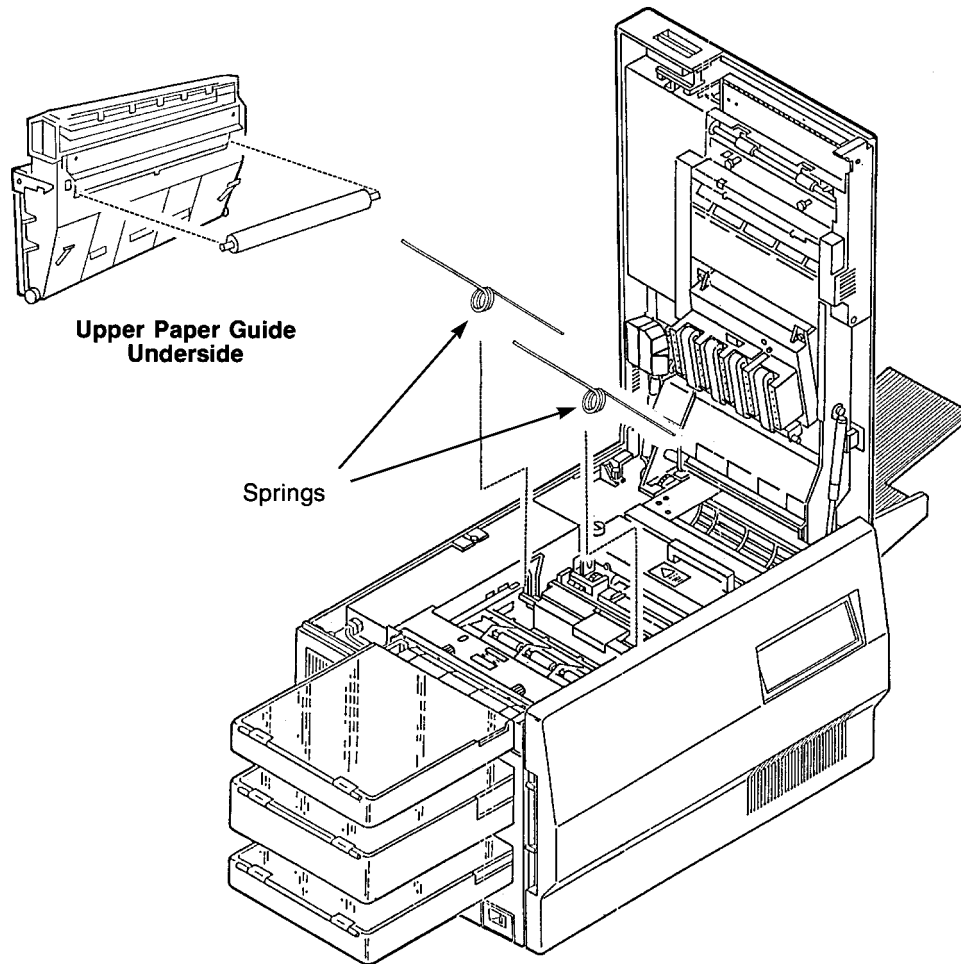

Lower Paper Guide Removal

- 1 Open the top cover.
- 2 Raise the upper paper guide.
- 3 Raise the lower paper guide slightly.
- 4 Push the base of the lower paper guide toward the back of the printer until the front mounting peg is free.
- 5 Lift the lower paper guide out of the printer.

Note: Use caution. This piece is made of plastic and can easily break if mishandled.

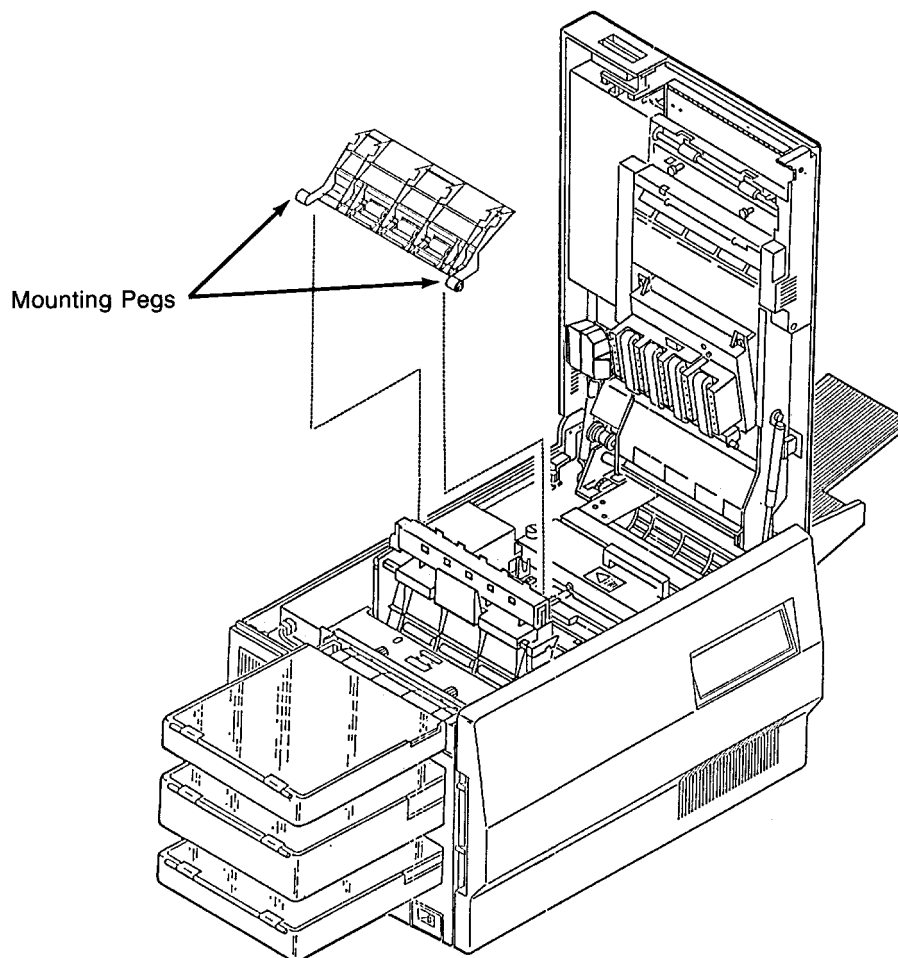

Paper Timing Guide Removal

- 1 Open the front, back, and top covers.
- 2 Raise the upper paper guide.
- 3 Remove the lower paper guide. (See [page 7-48.](#))
- 4 Remove the front screw holding the paper timing guide in place.

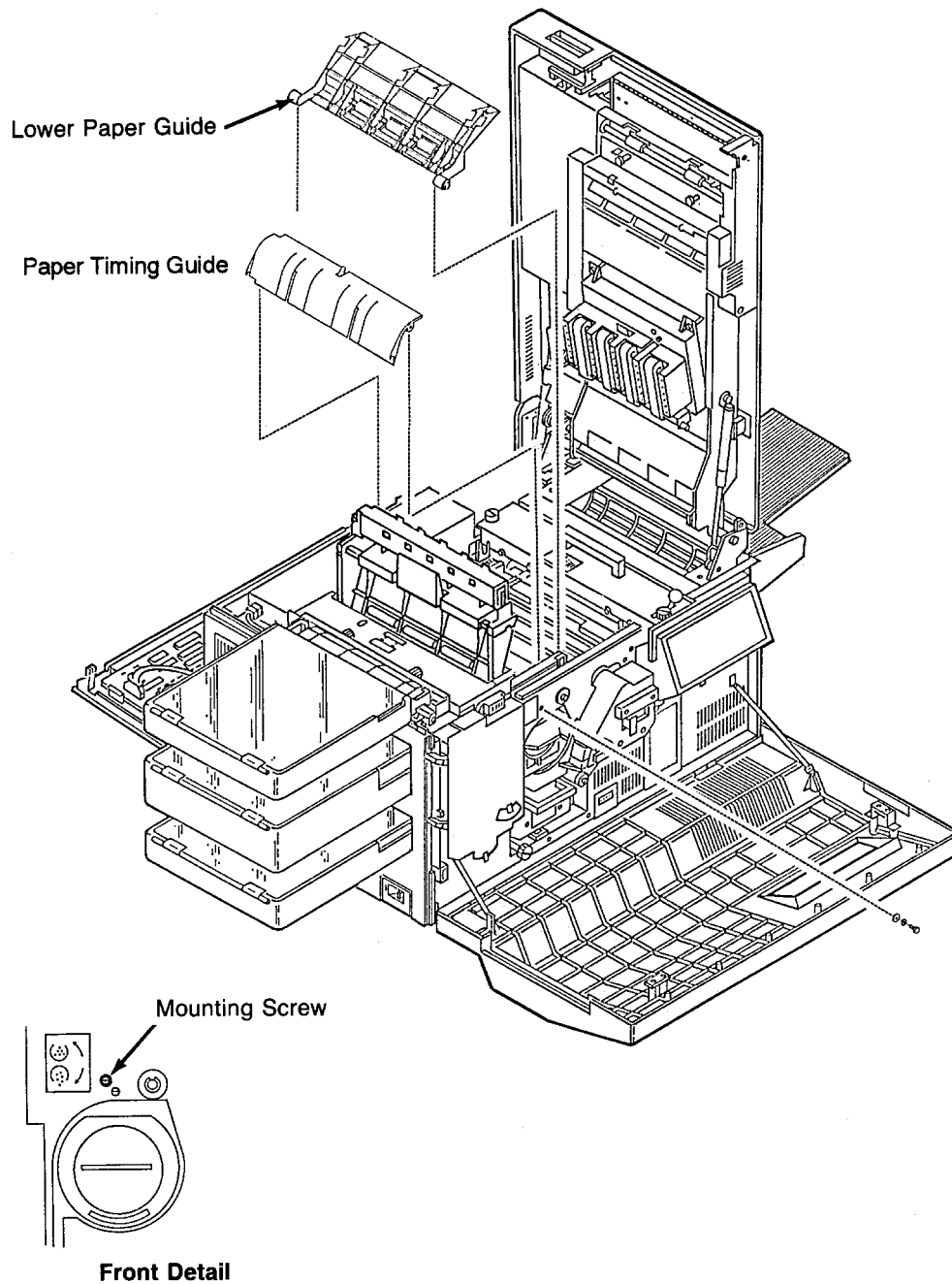

Paper Timing Guide Removal

- 5 Remove the paper feed drive cover (three screws).
- 6 Remove the back screw holding the paper timing guide in place. Remove the paper timing guide.
- 7 Disconnect CN58.

Note: When reinstalling the paper timing guide, be sure the guide is properly aligned on the mounting pins.

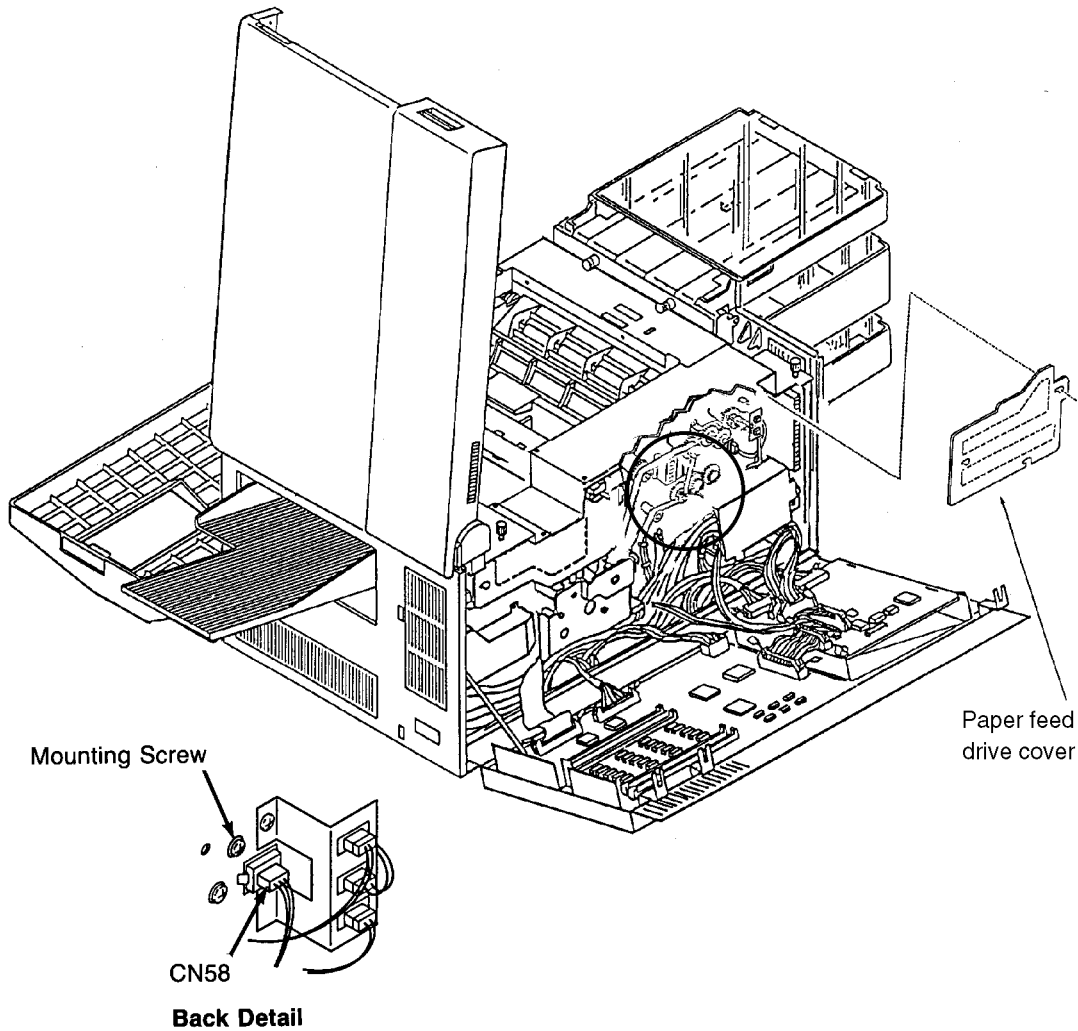

Cleaner Drive Belt Removal

- 1 Open the back cover.
- 2 Remove the fuser drive cover (three screws).
- 3 Remove the main drive cover (one screw).
- 4 Lift the idler arm and slide the cleaner drive belt off the gear.

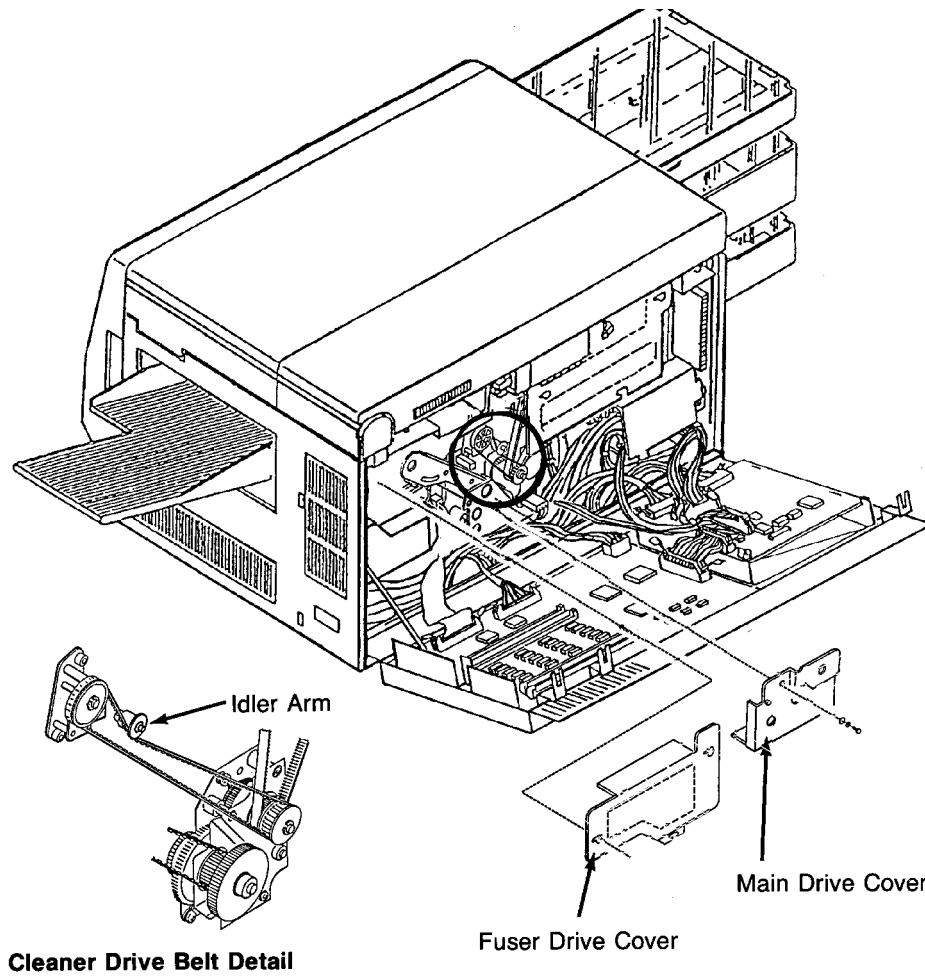

Cleaner Drive Removal

- 1 Open the back cover.
- 2 Remove the fuser drive cover (three screws).
- 3 Remove the main drive cover (one screw).
- 4 Remove the cleaner drive belt. (See [page 7-51.](#))
- 5 Remove the two high voltage leads.
- 6 Remove the cleaner drive (three screws).

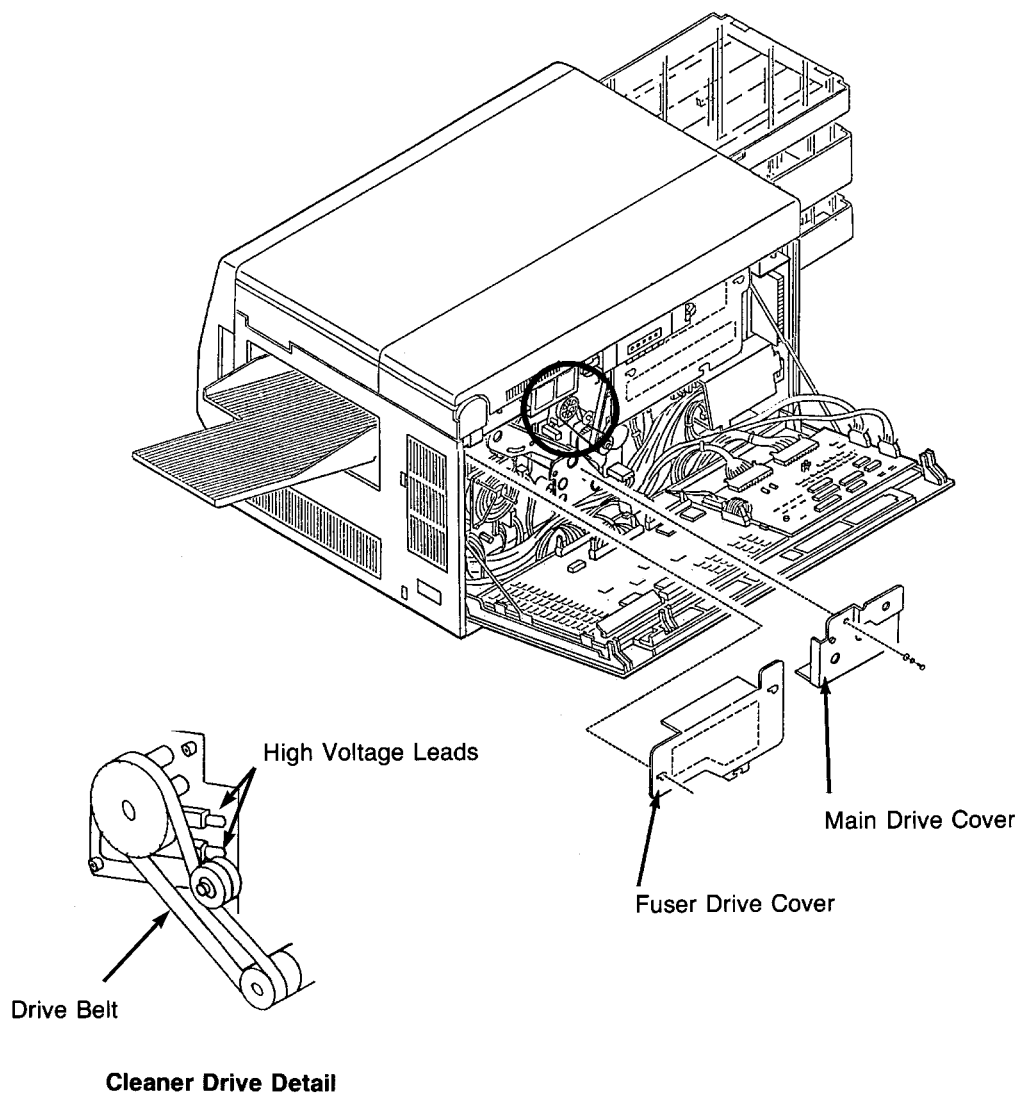

Fuser Drive Belt Removal

- 1 Open the back cover.
- 2 Remove the fuser drive cover (three screws).
- 3 Remove the main drive cover (one screw).
- 4 Remove the gear stay cover (one screw).
- 5 Remove the gear stay (three screws).
- 6 Remove the main drive gear and bearing (two C-clips and a washer).
- 7 Remove the single upper left and the two lower screws holding the fuser drive in place.
- 8 Loosen the upper right screw for the fuser drive and pivot the drive down.
- 9 Slide the fuser drive belt off the gear.

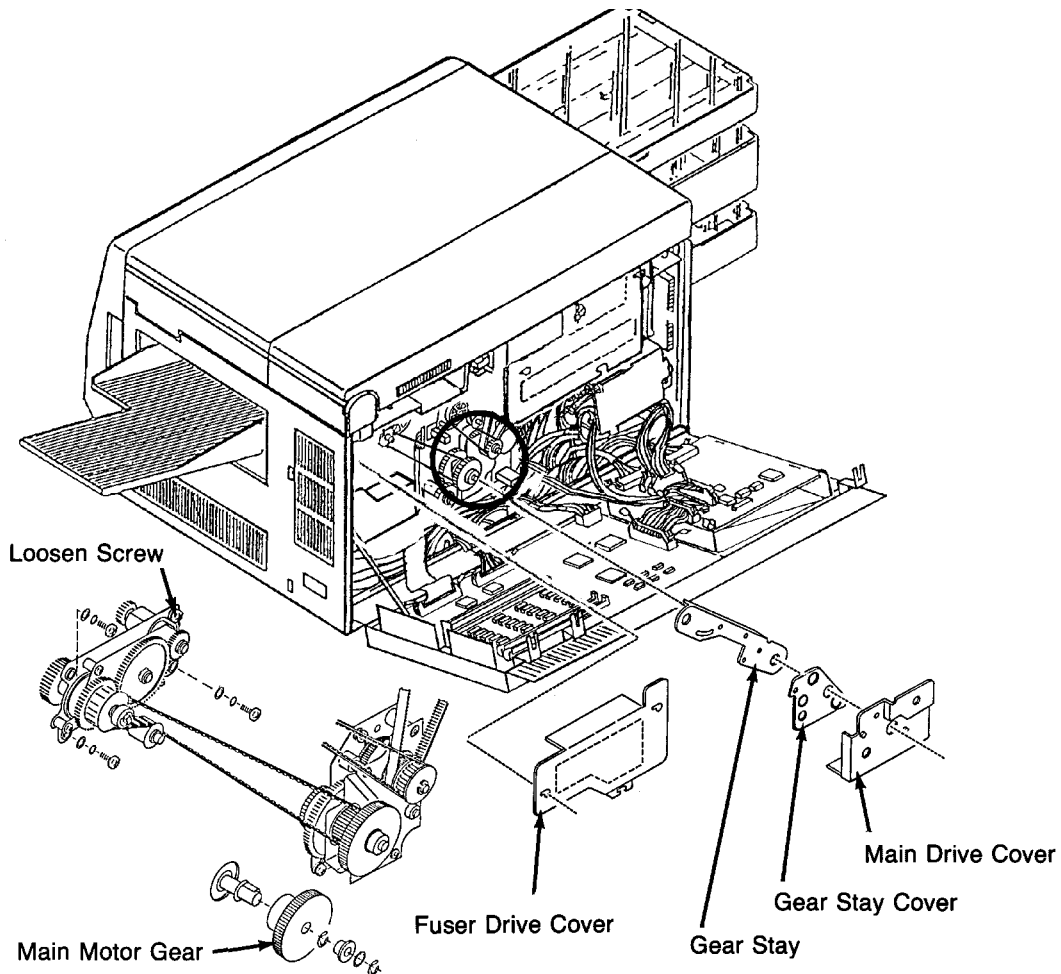

Fuser Drive Belt Detail

Fuser Drive Removal

- 1 Open the back cover.
- 2 Remove the fuser drive cover (three screws).
- 3 Remove the main drive cover (one screw).
- 4 Remove the gear stay cover (one screw).
- 5 Remove the gear stay (three screws).
- 6 Remove the fuser drive belt. (See [page 7-53.](#))
- 7 Remove the fuser drive (four screws).

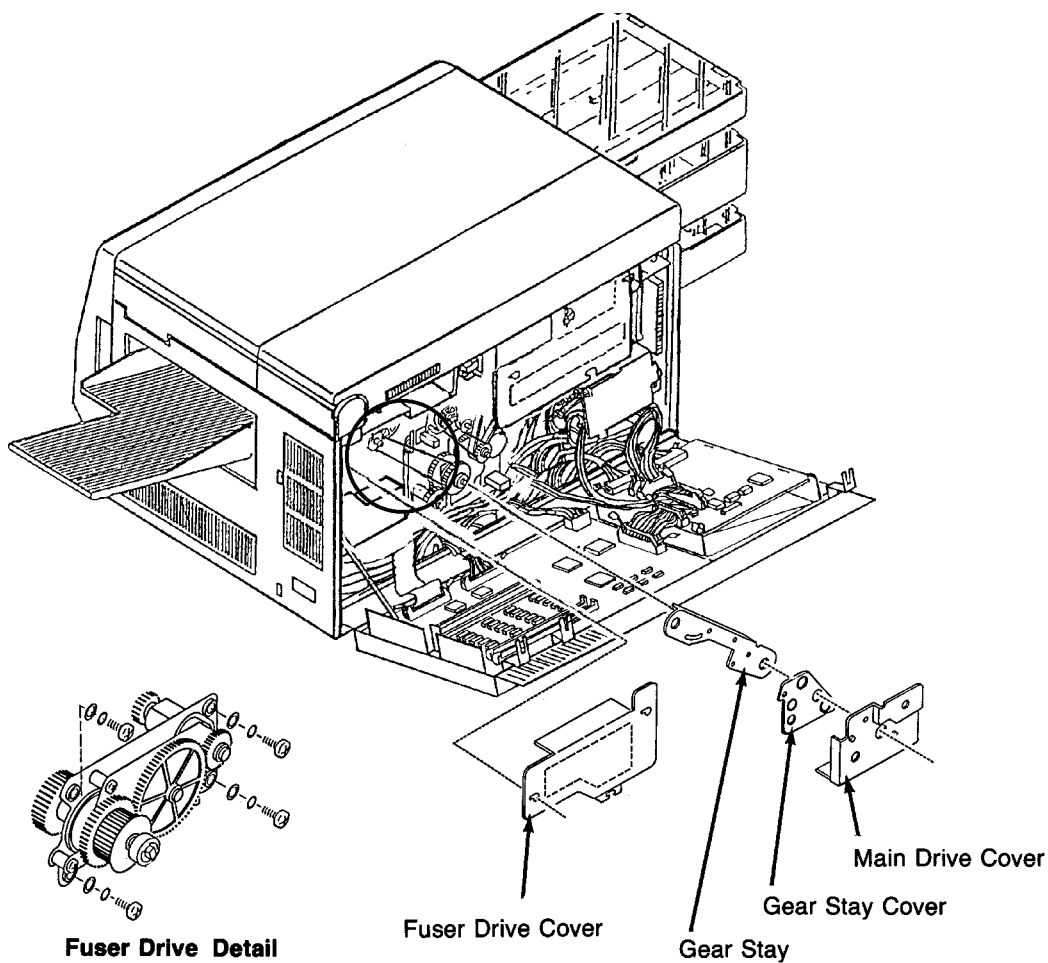

Paper Feed Drive Belt Removal

- 1 Open the back cover.
- 2 Remove the fuser drive cover (three screws).
- 3 Remove the paper feed drive cover (three screws).
- 4 Remove the main drive cover (one screw).
- 5 Remove the cleaner drive belt. (See [page 7-51.](#))
- 6 Push down on the idler arm and slide the paper feed drive belt off the gear.

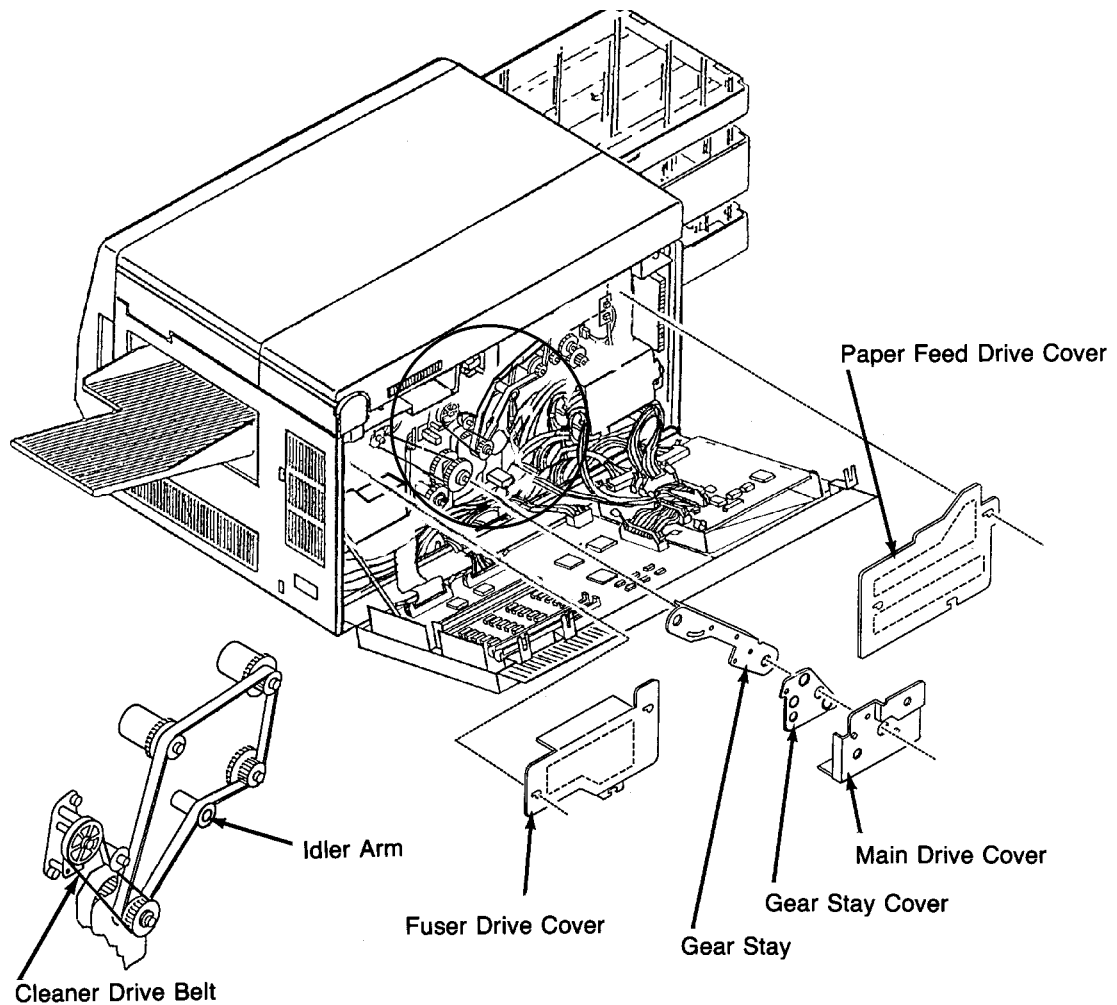

Paper Timing Roller Removal

- 1 Open the front, back, and top covers.
- 2 Raise the upper paper guide.
- 3 Remove the photoconductor and place it in its protective bag.
- 4 Remove the paper feed drive cover (three screws).
- 5 Remove the paper feed drive belt from the paper timing roller gear.
- 6 Disconnect CN65.
- 7 Unscrew the standoff post from the collar surrounding the end of the roller.
- 8 Remove the C-clip and bearing from the front of the printer.
- 9 Slide the paper timing roller out the back of the printer.

Replacement Notes:

Reinstall the original collar and standoff post with any new paper timing roller. The C-clip should move freely if installed correctly. Be sure to align all of the guide pins or the C-clip will not fit correctly. Be careful not to scratch the surface of the roller when inserting it into the printer.

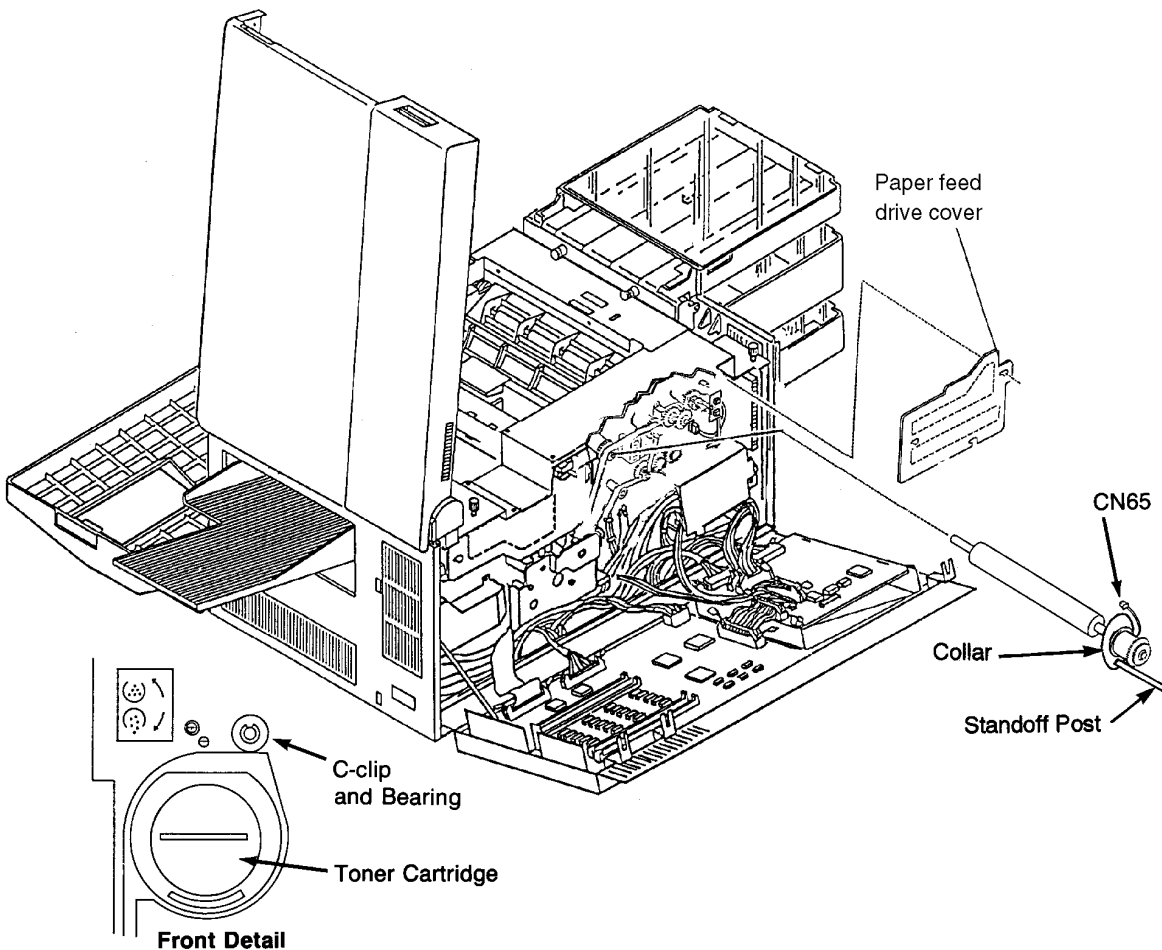

Upper Feed Roller Removal

- 1 Open the front and back covers.
- 2 Remove the paper feed drive cover (three screws).
- 3 Disconnect CN66.
- 4 Remove the paper feed drive belt from the upper feed roller gear.
- 5 Remove the cassette release cover (two screws).
- 6 Remove the front C-clip and bearing from the front of the printer.
- 7 Slide the upper feed roller out the back of the printer.

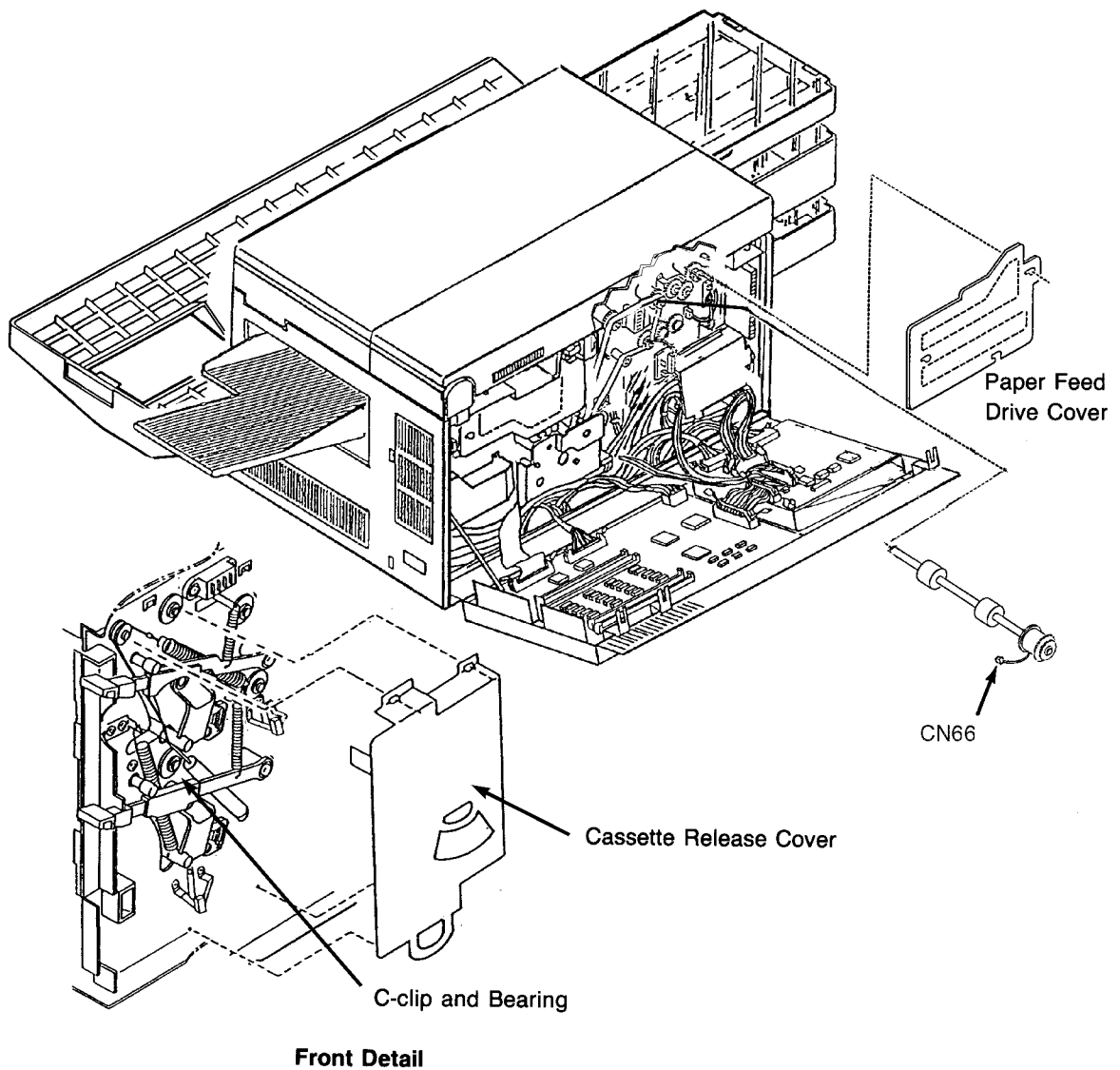

Lower Feed Roller Removal

- 1 Open the front and back covers.
- 2 Remove the paper feed drive cover (three screws).
- 3 Disconnect CN67.
- 4 Remove the paper feed drive belt from the lower feed roller gear.
- 5 Remove the cassette release cover (two screws).
- 6 Remove the C-clip and bearing from the front of the printer.
- 7 Slide the lower feed roller out the back of the printer.

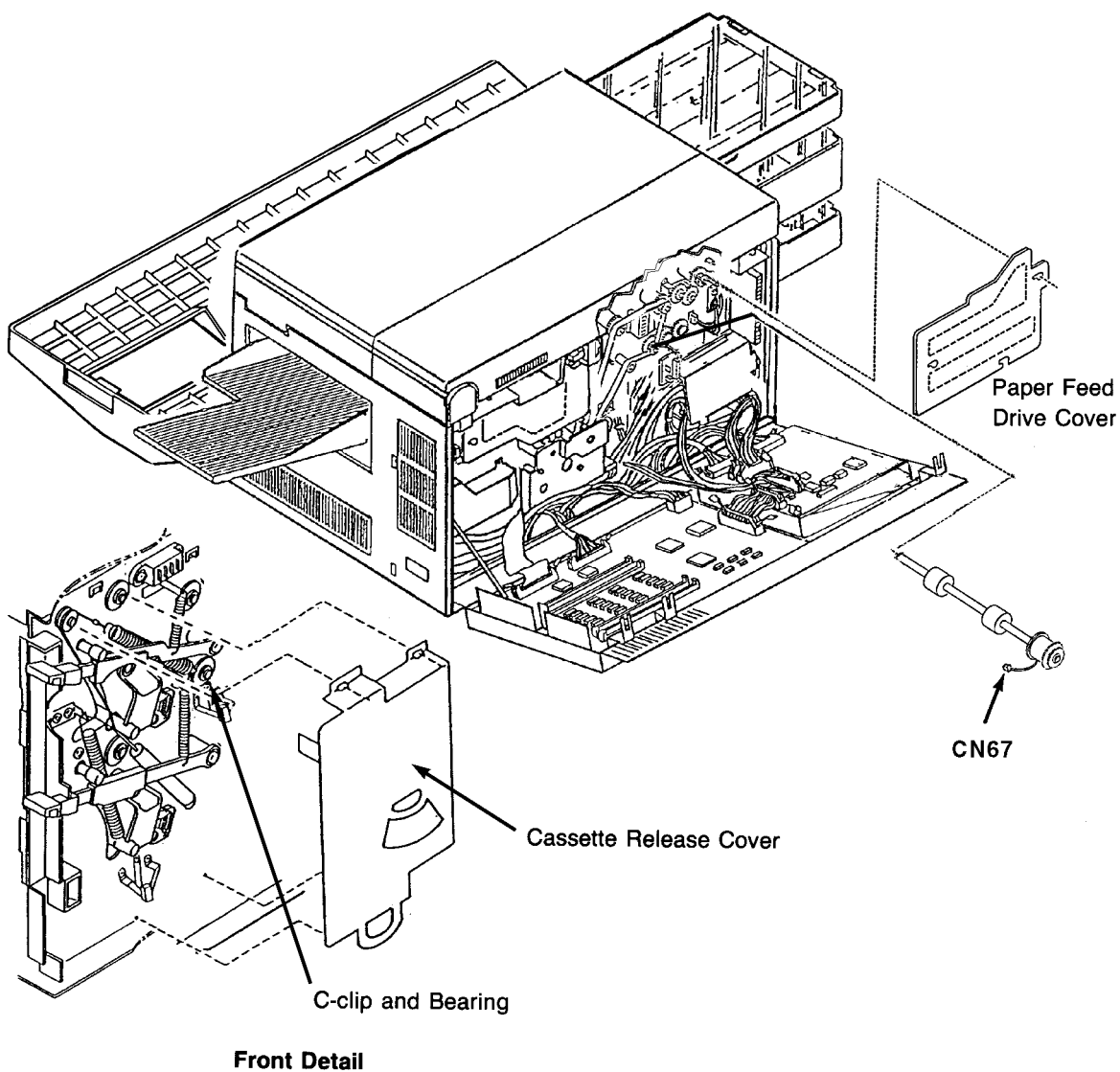

Upper Pick-Up Roller Removal

- 1 Open the front and back covers.
- 2 Remove the paper feed drive cover (three screws).
- 3 Disconnect CN68.
- 4 Remove the cassette release cover (two screws).
- 5 Remove the C-clip and bearing from the front of the printer.
- 6 Remove the pick-up roller drive belt from the gears.
- 7 Slide the upper pick-up roller out the back of the printer.

Note: You may need to remove the EMI grounding plate.

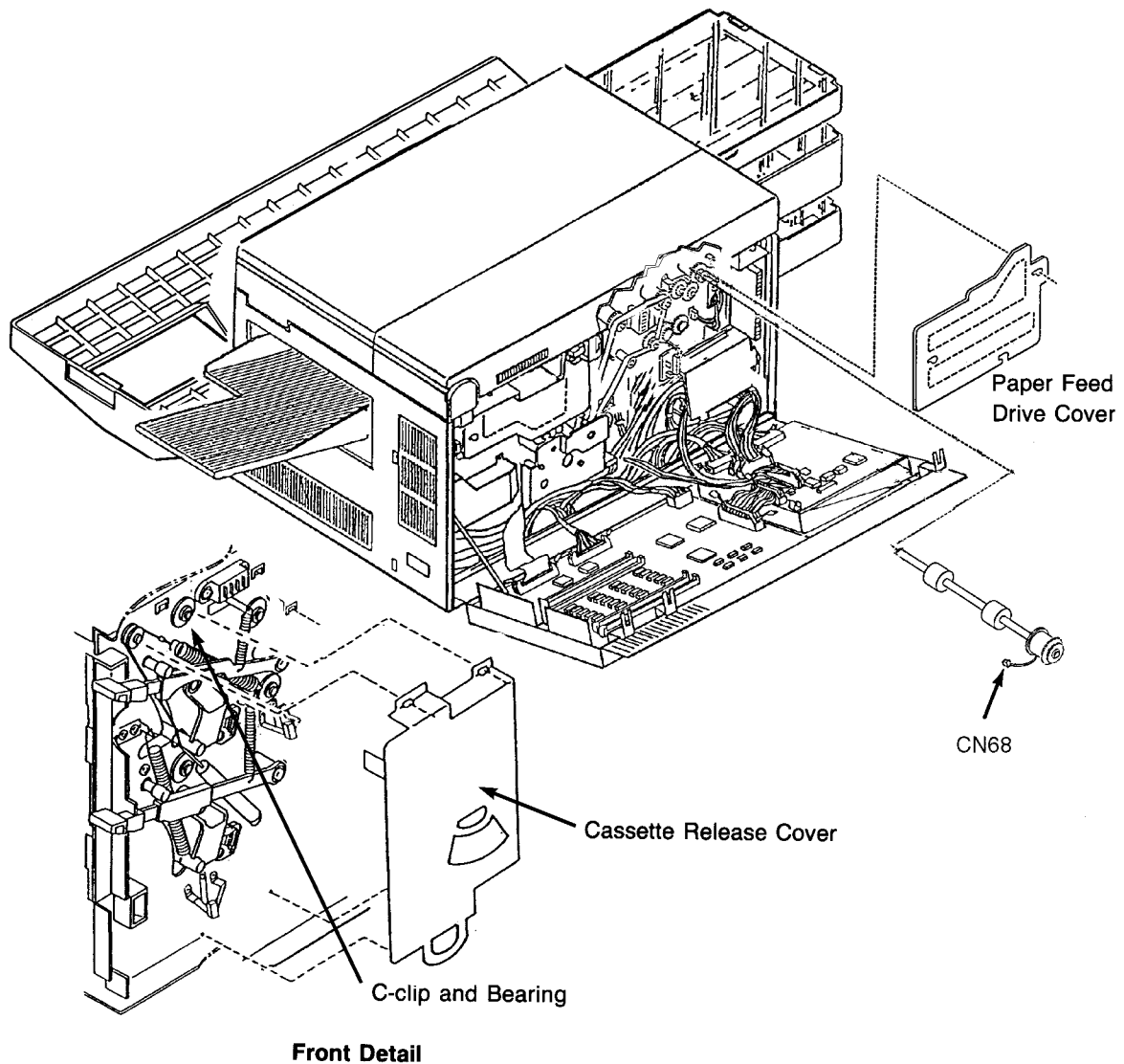

Pick-Up Roller Drive Idler Removal

Pick-Up Roller Drive Idler Removal

- 1 Open the front and back covers.
- 2 Remove the paper feed drive cover (three screws).
- 3 Remove the pick-up roller drive belt from the pick and feed gears.
- 4 Remove the pick-up roller drive idler (three screws).

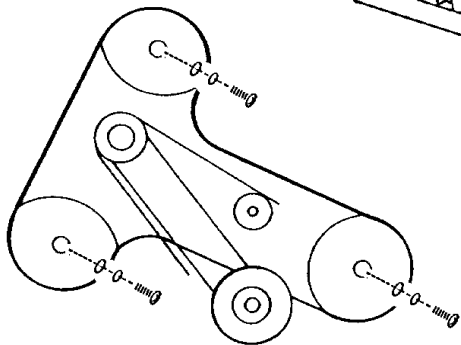
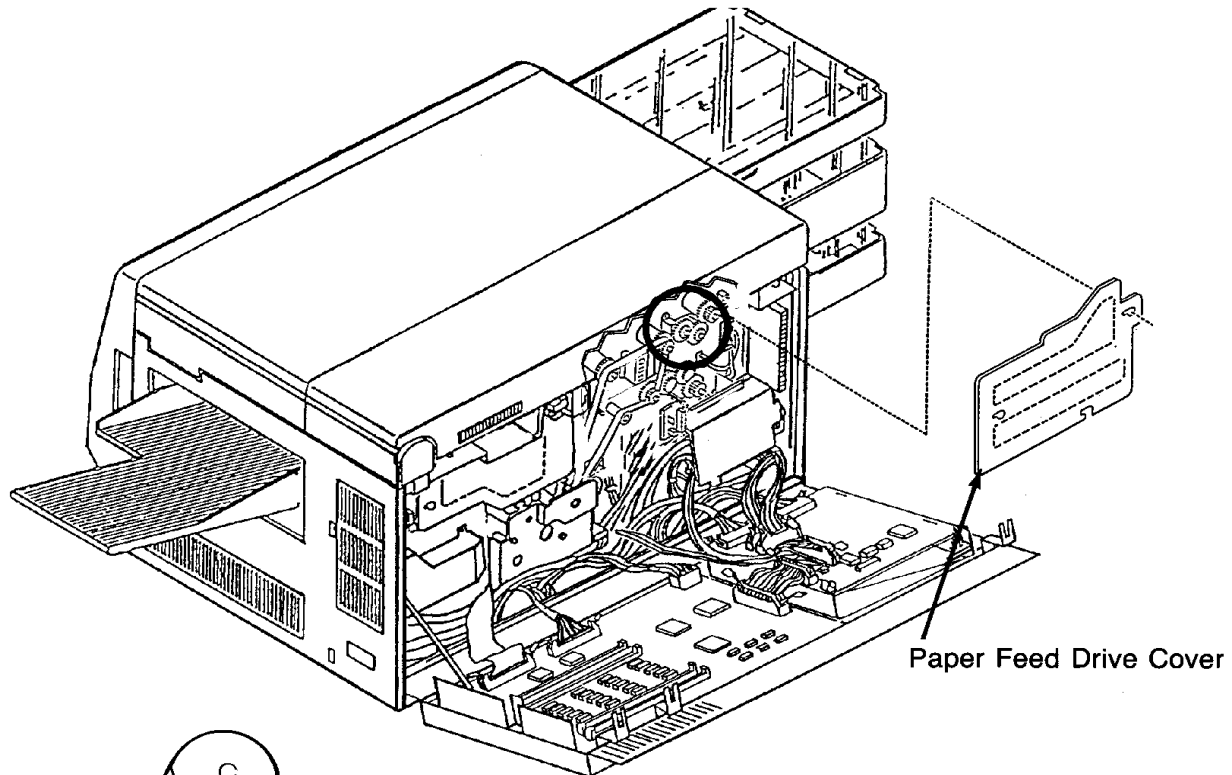

Pick-up Roller Idler Detail

Pick-Up Roller Drive Gear Removal

- 1 Open the back cover.
- 2 Remove the paper feed drive cover (three screws).
- 3 Remove the pick-up roller drive belt.
- 4 Remove the pick-up roller drive gear and housing (three screws).

Note: You may need to remove the EMI grounding plate.

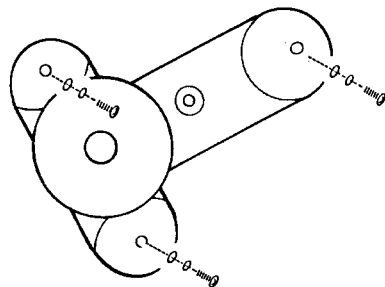
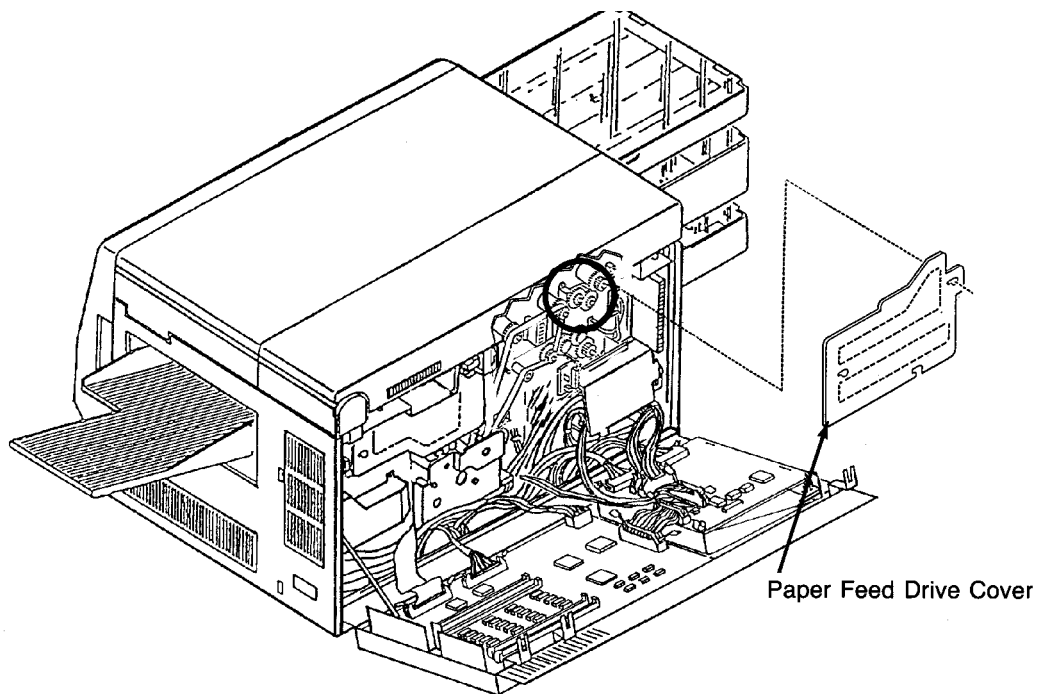

Pick-up Roller Gear Detail

Lower Pick-Up Roller Removal

- 1 Open the front and back covers.
- 2 Remove the paper feed drive cover (three screws).
- 3 Disconnect CN69.
- 4 Remove the cassette release cover (two screws).
- 5 Remove the front C-clip and bearing.
- 6 Slide the lower pick-up roller out the back of the printer.

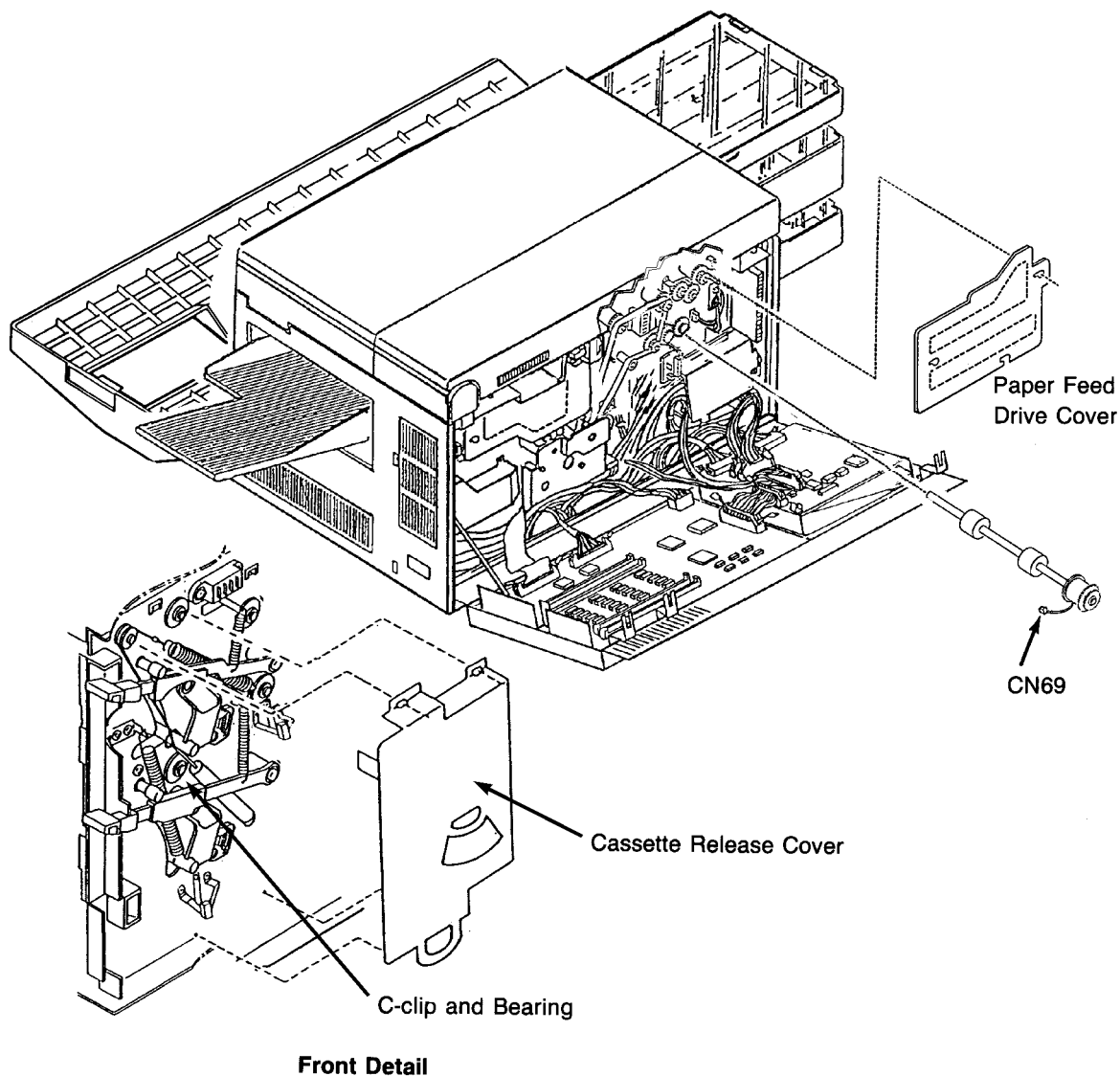

Exit Assembly Removal

- 1 Open the front, top, and back covers.
- 2 Remove the paper output tray.
- 3 Remove the right side cover. (See [page 7-8.](#))
- 4 Remove the operator panel. (See [page 7-12.](#))

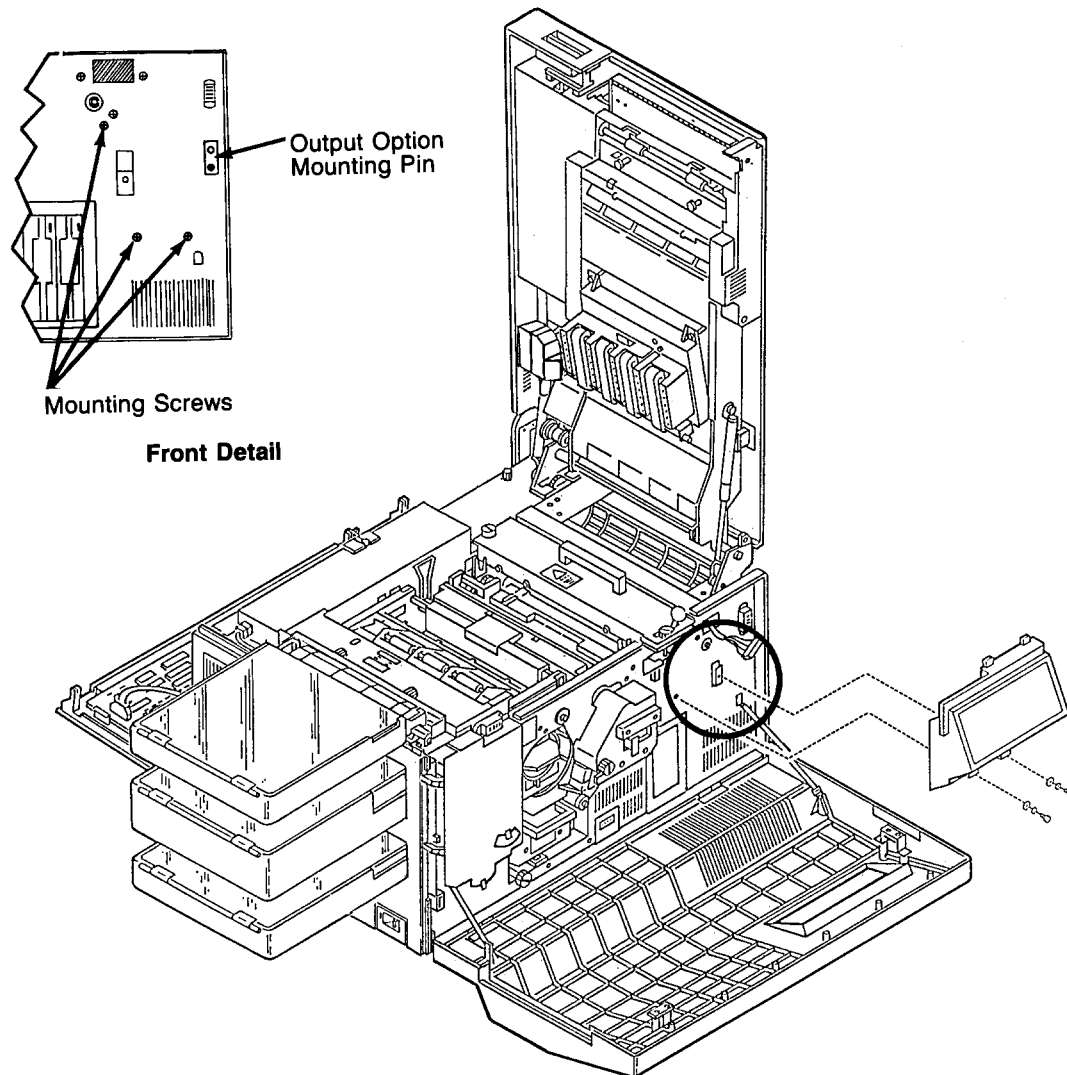

- 5 Remove the DC power supply. (See [page 7-26.](#))
- 6 Remove the mounting bracket for the DC power supply by removing two screws and prying out the bracket with a small screw driver.
- 7 Remove the fuser drive cover (three screws).

Exit Assembly Removal

- 8 Remove the five screws holding the job exit assembly in place (three screws in front; two screws in back).
- 9 Remove the fuser drive cover mounting post.
- 10 Remove the mounting pin for the output option (one screw).
- 11 Remove the job exit assembly.

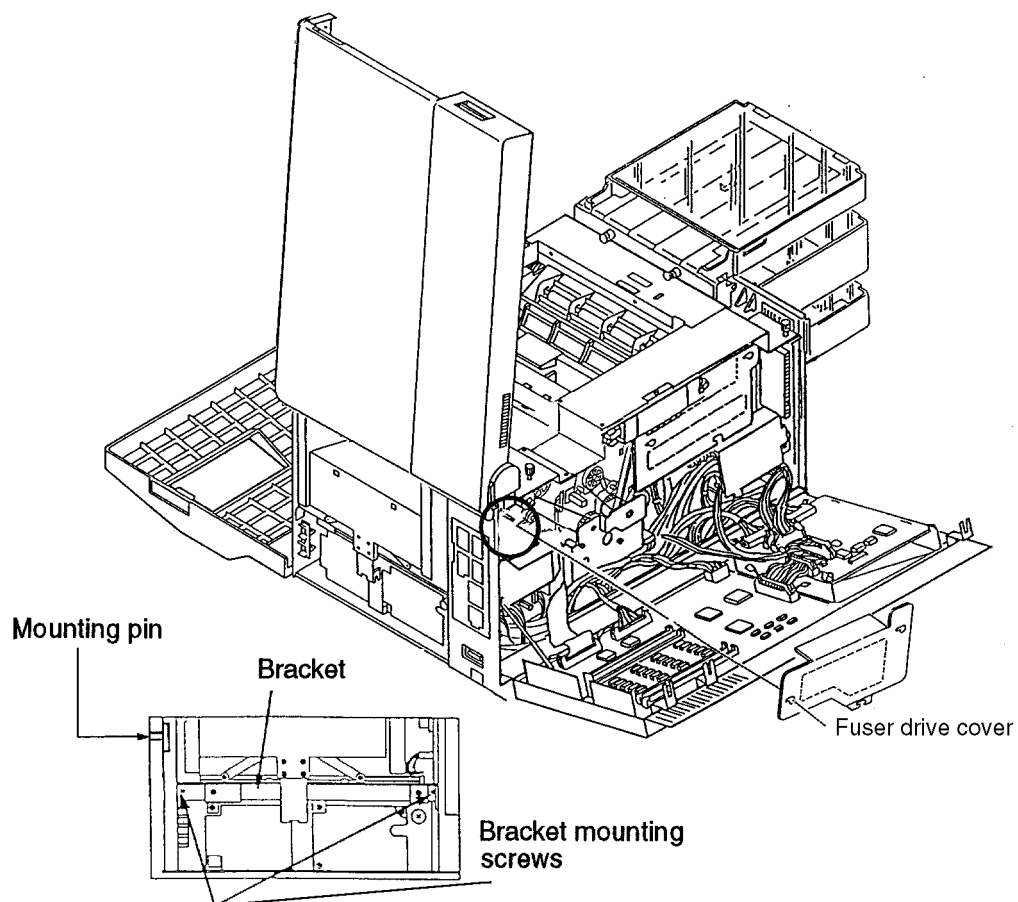

Exit Pinch Roller Removal

- 1 Open the front, back, and top covers.
- 2 Remove the fuser.
- 3 Remove the operator panel. (See [page 7-12.](#))
- 4 Remove the front screw holding the exit pinch roller in place.
- 5 Remove the front screw holding the exit guide in place.

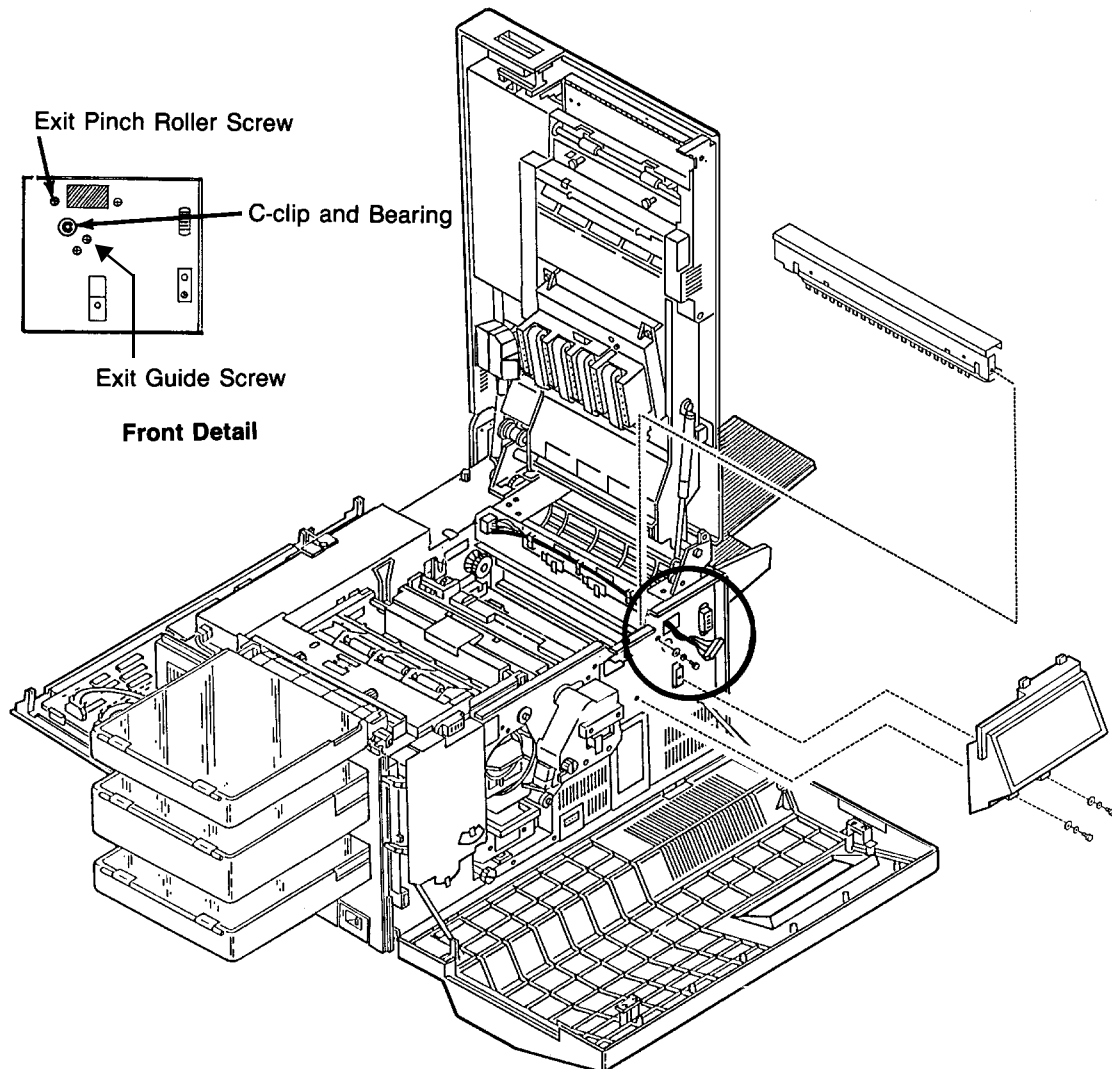

- 6 Remove the fuser drive cover (three screws).
- 7 Remove the back screw holding the exit pinch roller in place.
- 8 Lift the exit pinch roller from the printer.

Exit Pinch Roller Removal

Note: Use caution so as not to damage the paper full or exit sensors.

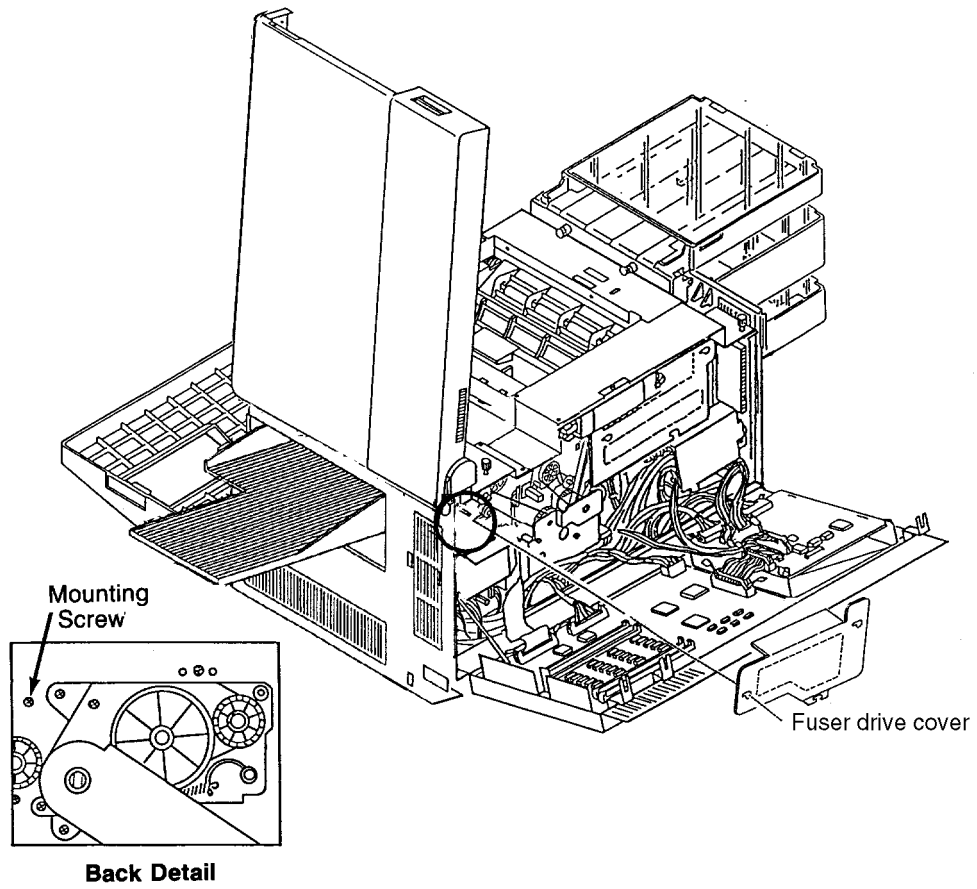

Upper Static Brush Removal

- 1 Open the top and front covers.
- 2 Remove the fuser.
- 3 Remove the upper static brush from the exit pinch roller assembly (two screws).

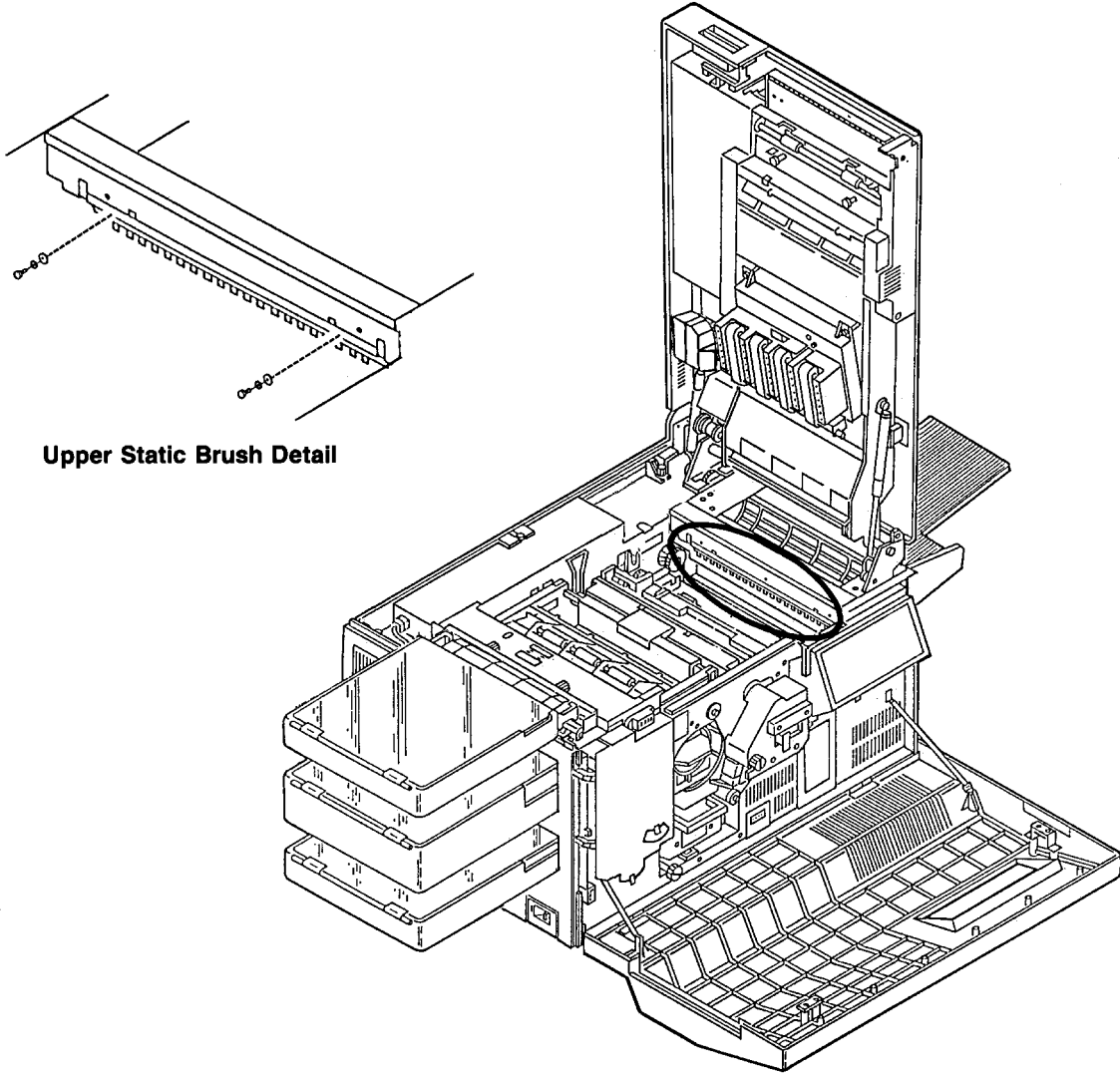

Upper Static Brush Detail

Lower Static Brush Removal

- 1 Open the top, front and back covers.
- 2 Remove the fuser.
- 3 Remove the operator panel. (See [page 7-12.](#))
- 4 Remove the exit pinch roller assembly. (See [page 7-65.](#))
- 5 Remove the lower static brush (two screws).

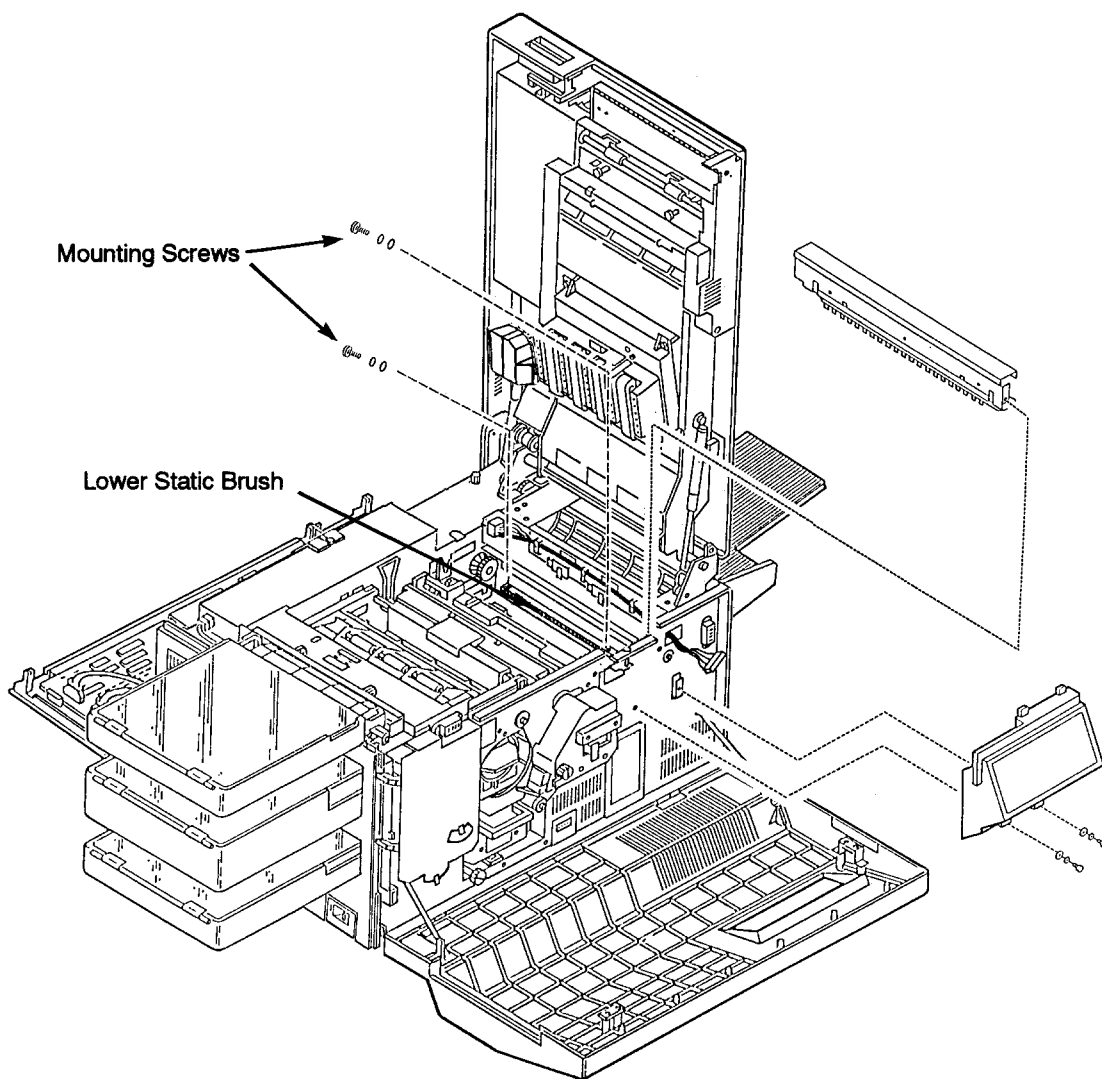

Exit Roller Assembly Removal

- 1 Open the front, back, and top covers.
- 2 Remove the fuser.
- 3 Remove the operator panel. (See [page 7-12.](#))
- 4 Remove the front screw holding the exit guide in place.

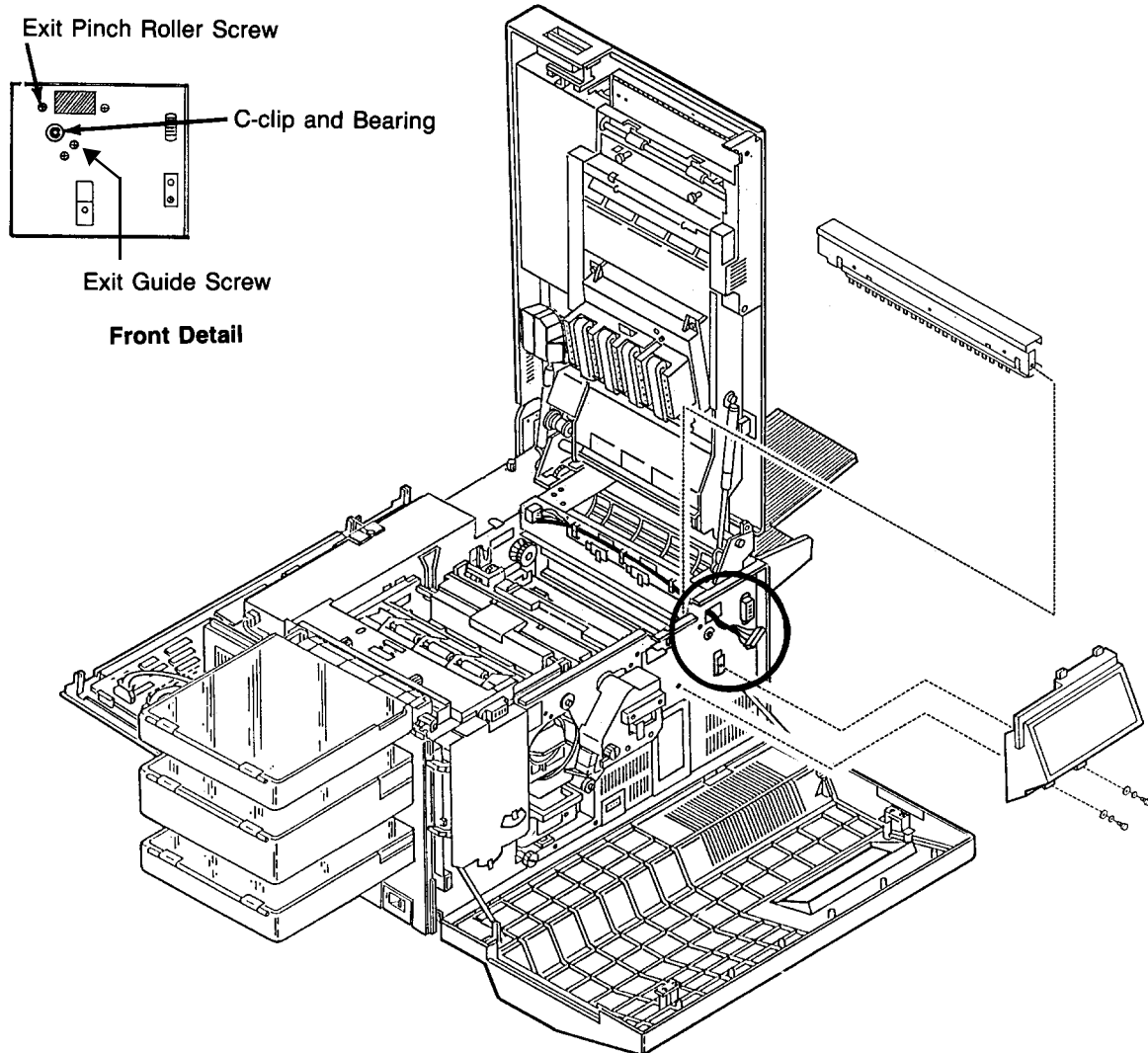

- 5 Remove the fuser drive cover (three screws).
- 6 Remove the exit pinch roller. (See [page 7-65.](#))
- 7 Remove the lower duplex drive (three screws).
- 8 Remove the back screw holding the exit guide in place.

Exit Roller Assembly Removal

9 Tilt the exit guide toward the center of the printer.

10 Remove the front C-clip and bearing.

11 Slide the exit roller out the back of the printer.

Note: Use caution so as not to damage the paper full or exit sensors.

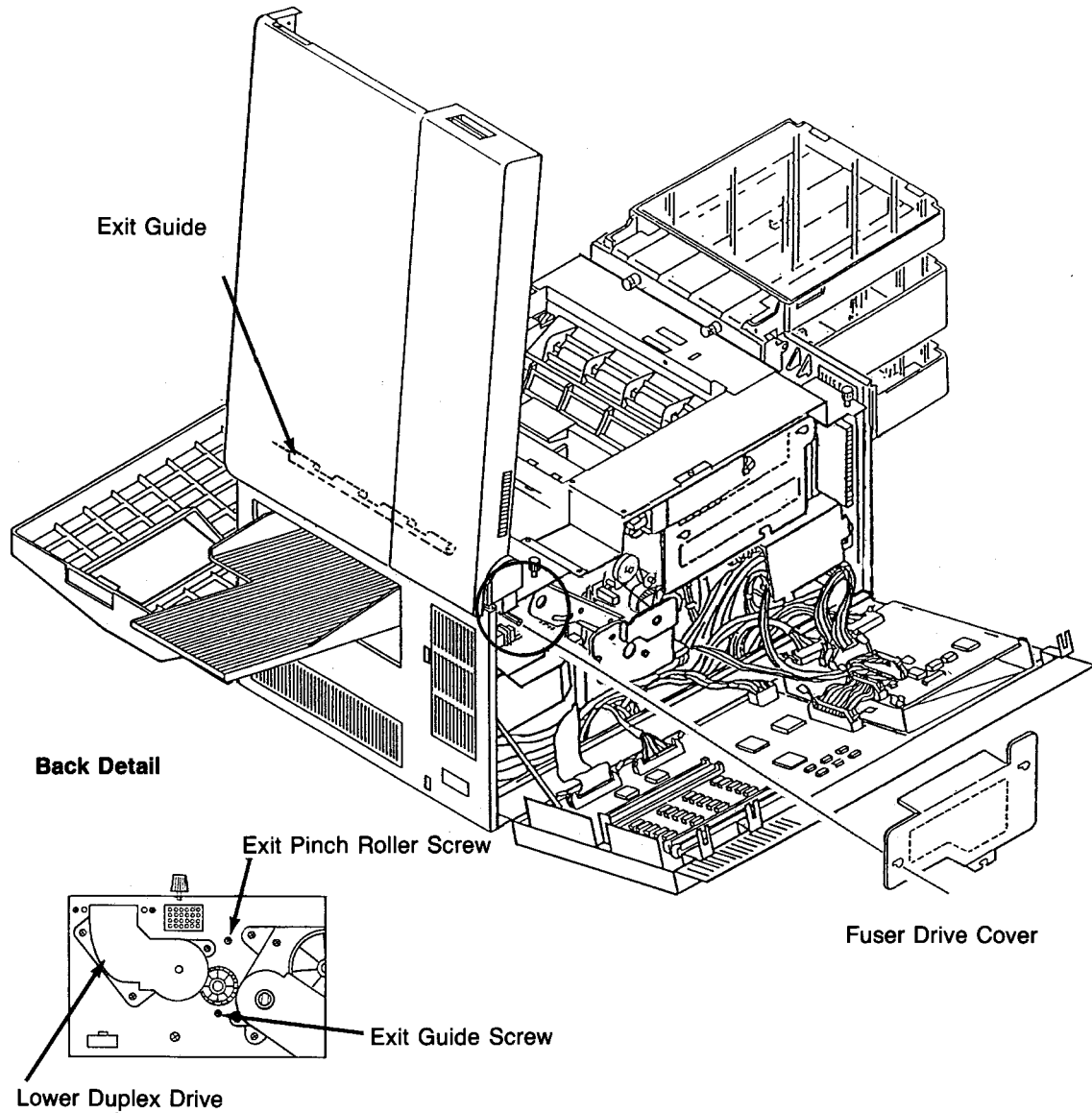

Exit Cover Removal

- 1 Open the front, top, and back covers.
- 2 Remove the fuser.
- 3 Remove the paper output tray.
- 4 Remove the right side cover. (See [page 7-8.](#))
- 5 Remove the operator panel. (See [page 7-12.](#))

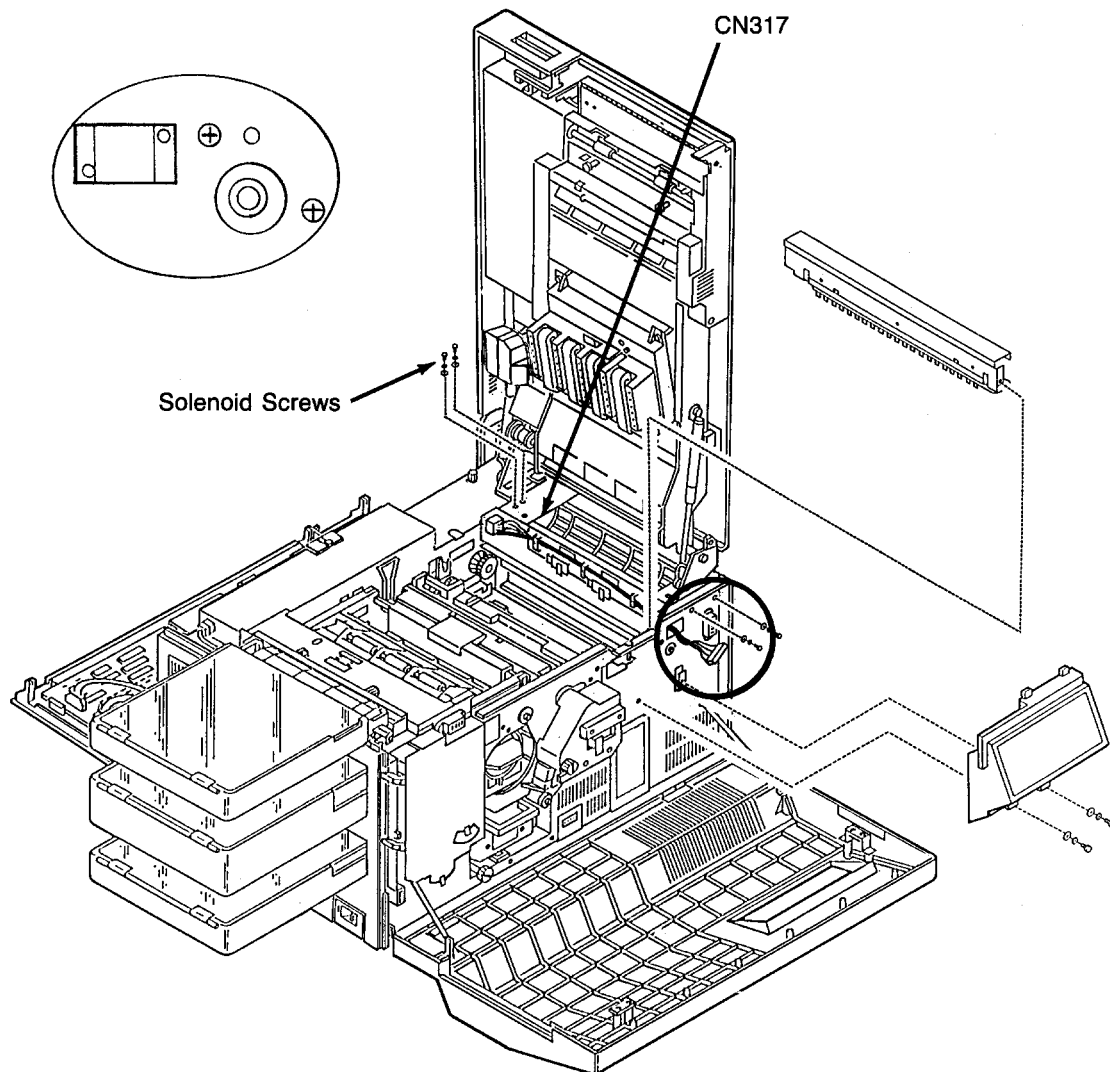

- 6 Remove the fuser drive cover (three screws).
- 7 Remove the exit pinch roller. (See [page 7-65.](#))
- 8 Disconnect CN49 and CN51.

Exit Cover Removal

- 9 Remove the wiring harness for CN42, CN49, and CN51 from the exit cover.
- 10 Disconnect CN317.
- 11 Remove the four screws holding the exit cover in place (two front and two back).
- 12 Lift the exit cover from the printer.
- 13 Remove the solenoid from the exit cover (two screws)

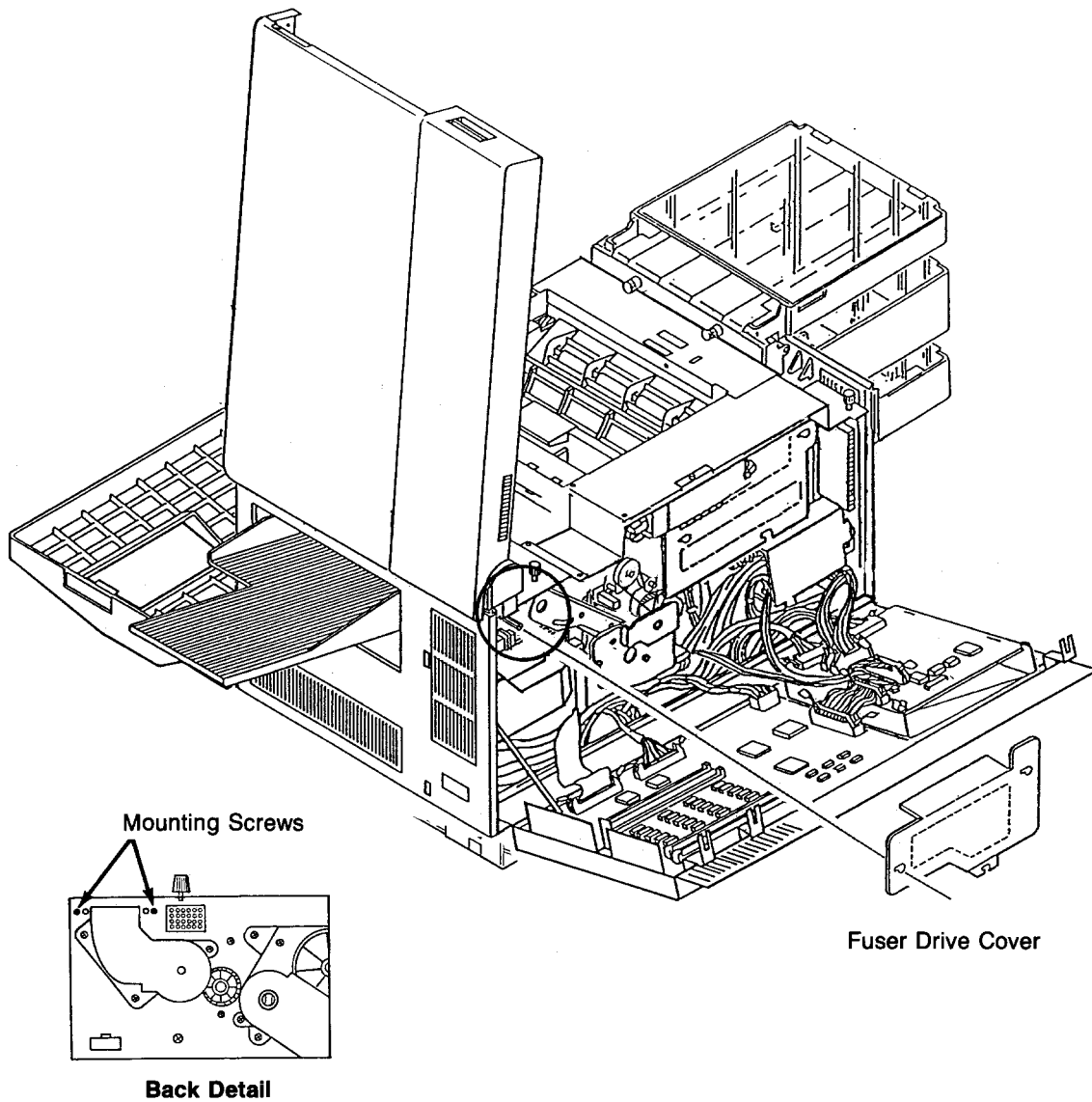

Paper Exit Sensor Removal

- 1 Open the front, back, and top covers.
- 2 Remove the fuser.
- 3 Remove the operator panel. (See [page 7-12.](#))
- 4 Remove the exit pinch roller. (See [page 7-69.](#))
- 5 Disconnect CN49.
- 6 Remove the two screws holding the exit cover in place (one front and one back).
- 7 Tilt the exit cover assembly toward the center of the printer.
- 8 From the underside, remove the paper exit sensor (one screw).

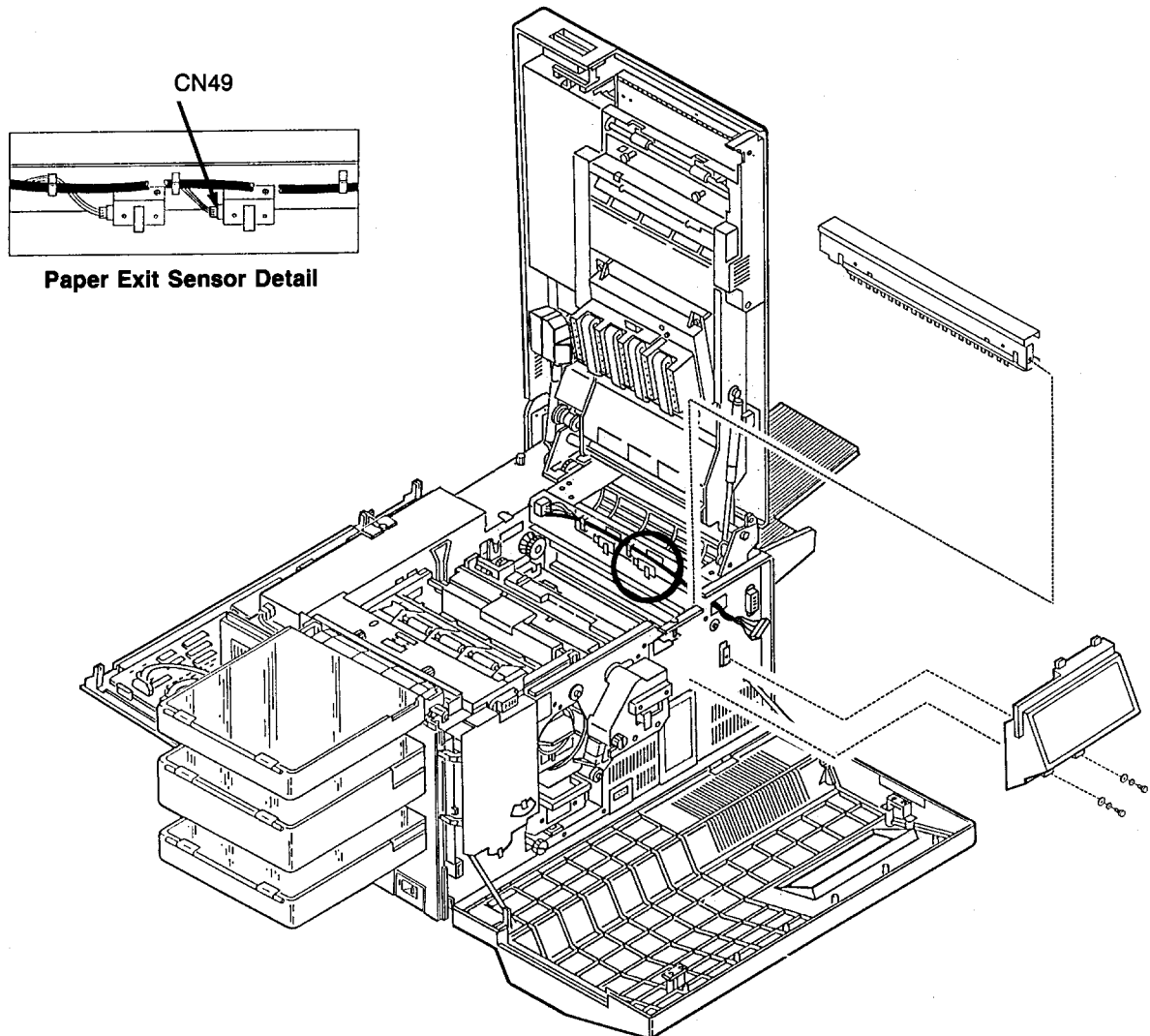

Paper Full Sensor Removal

- 1 Open the front, back, and top covers.
- 2 Remove the fuser.
- 3 Remove the operator panel. (See [page 7-12.](#))
- 4 Remove the exit pinch roller. (See [page 7-69.](#))
- 5 Disconnect CN51.
- 6 Remove the two screws holding the exit cover in place (one front and one back).
- 7 Tilt the exit cover toward the center of the printer.
- 8 From the underside, remove the paper full sensor (one screw).

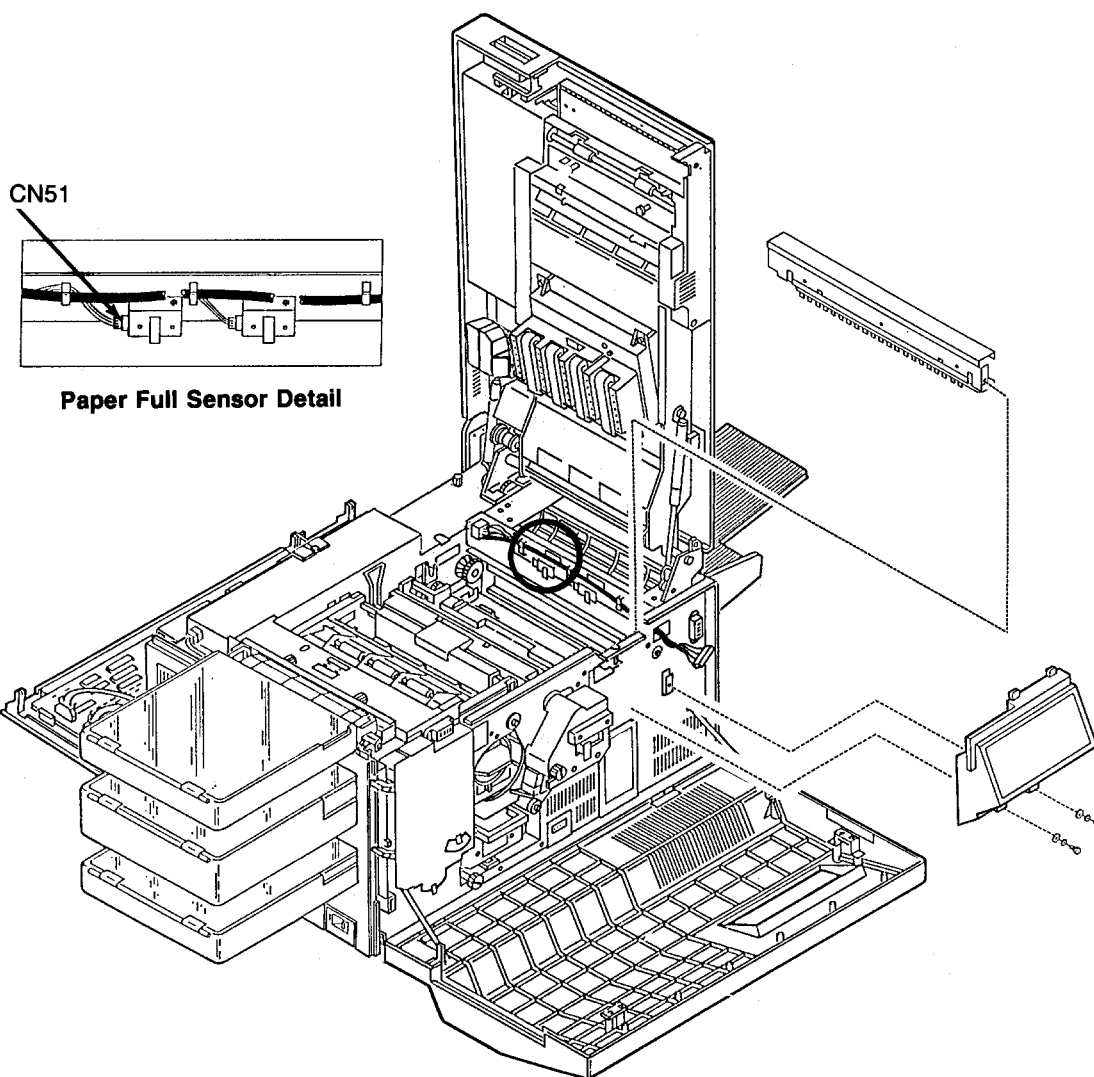

Front Cover Interlock Switch Removal

- 1 Open the front, top, and back covers.
- 2 Remove the duplex tray.
- 3 Remove the upper and lower paper cassettes.
- 4 Remove the left side cover. (See [page 7-7.](#))
- 5 Remove the AC power supply. (See [page 7-24.](#))
- 6 Remove the AC power supply top cover (two screws).
- 7 Disconnect the two wires connected to the interlock switch.
- 8 Remove the front interlock switch (two screws).

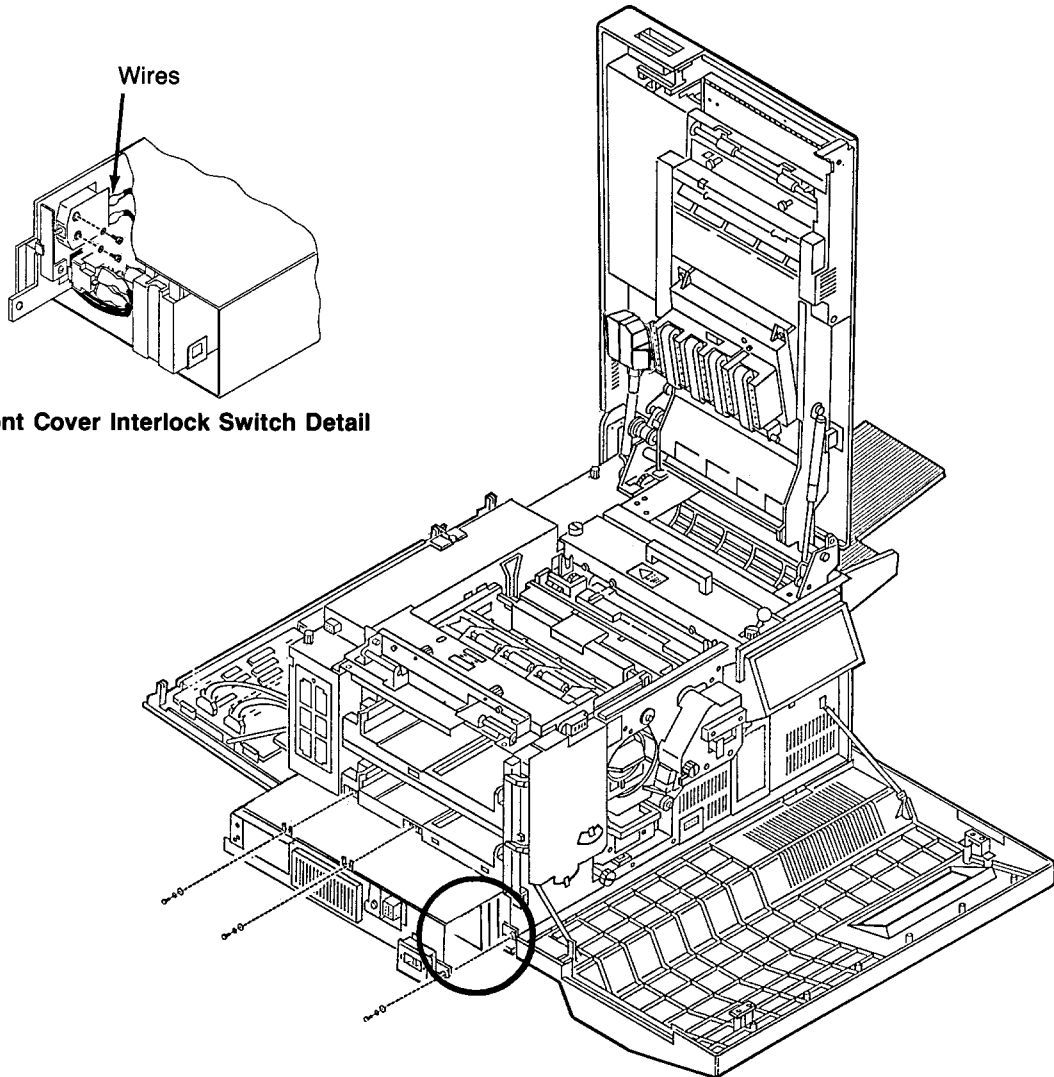

Front Cover Interlock Switch Detail

Back Cover Interlock Switch Removal

- 1 Open the front, top, and back covers.
- 2 Remove the duplex tray.
- 3 Remove the upper and lower paper cassettes.
- 4 Remove the left side cover. (See [page 7-7.](#))
- 5 Remove the AC power supply. (See [page 7-24.](#))
- 6 Remove the AC power supply side cover (one screw).
- 7 Disconnect the four wires connected to the interlock switch.
- 8 Remove the back cover interlock switch (two screws).

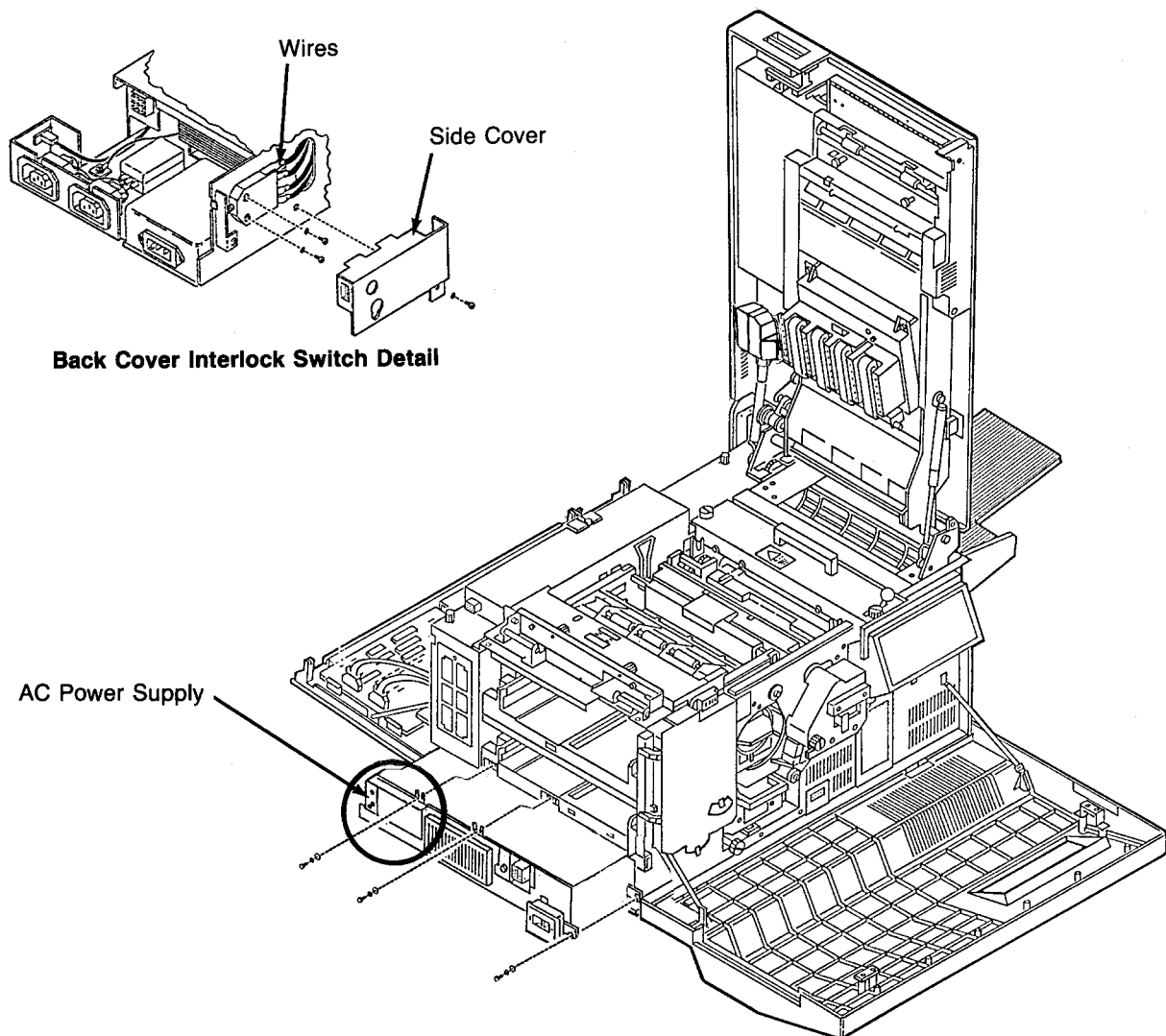

Top Cover Interlock Switch Removal

- 1 Open the top, front, and back covers.
- 2 Remove the duplex tray.
- 3 Remove the upper and lower paper cassettes.
- 4 Remove the left side cover. (See [page 7-7](#).)
- 5 Remove the duplex tray mount (four screws).
- 6 Remove the paper feed drive cover (two screws).
- 7 Disconnect the two wires connected to the interlock switch.
- 8 Remove the top cover interlock switch (two screws).

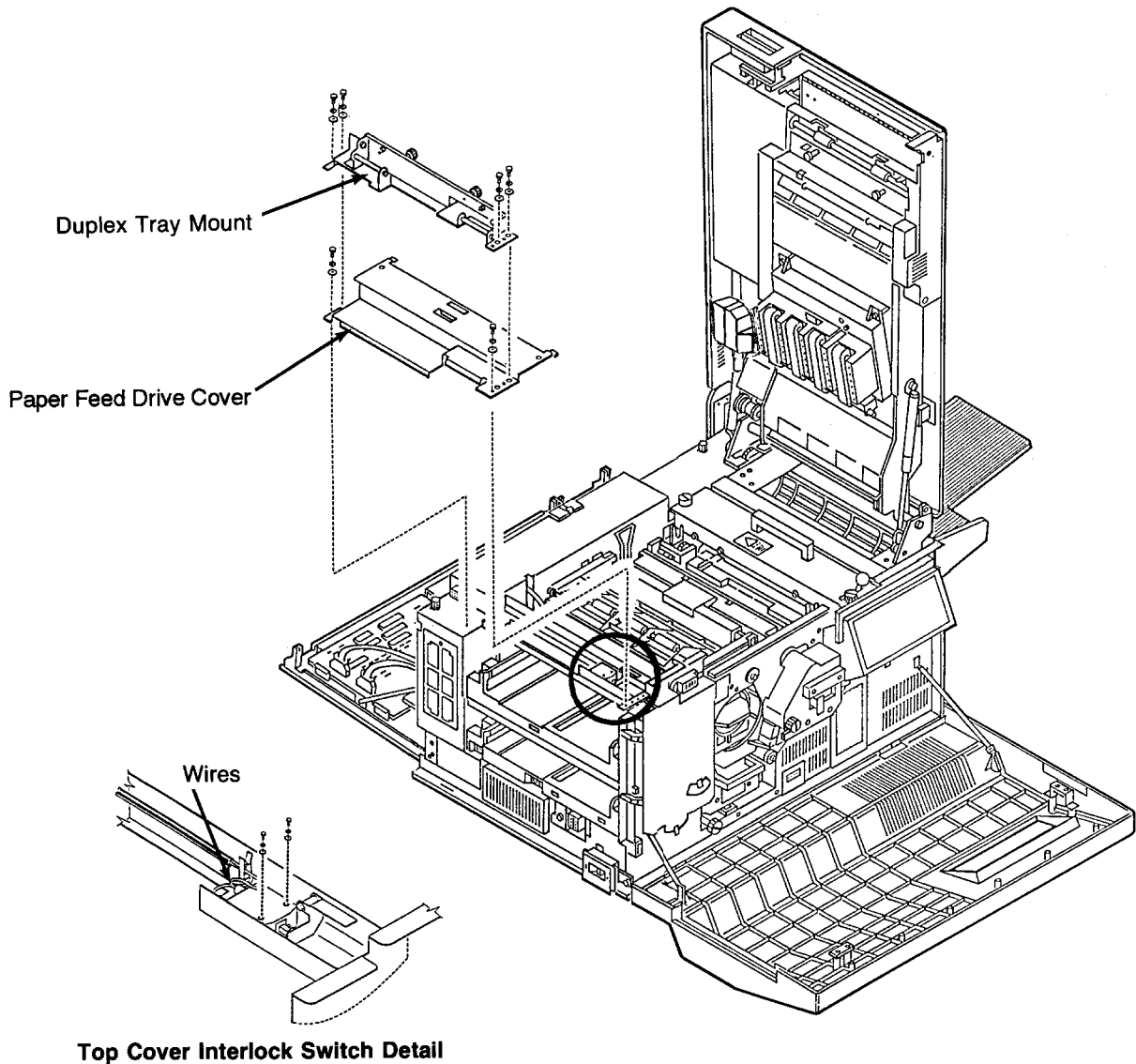

Erase Lamp Removal

Erase Lamp Removal

- 1 Open the top and back covers.
- 2 Remove the photoconductor and place it in its protective packaging.
- 3 Remove the fuser drive cover (three screws).
- 4 Disconnect CN26.
- 5 Remove the screw holding the erase lamp in place.
- 6 Disengage the front of the erase lamp from its guide pin.
- 7 Slide the unit out the back of the printer.

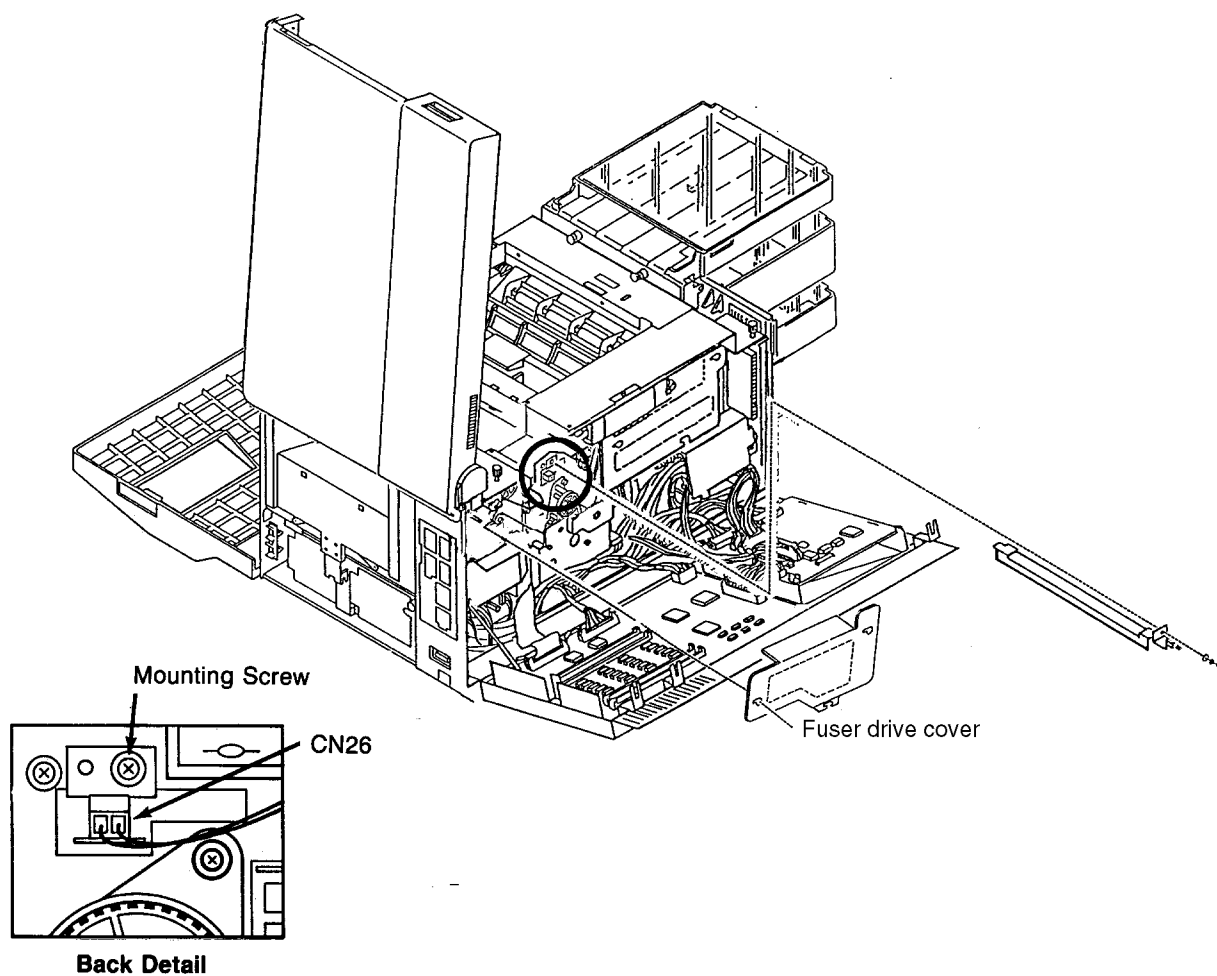

EP Cover Removal

- 1** Open the front, back, and top covers.
- 2** Remove the fuser.
- 3** Remove the photoconductor and place in its protective packaging.
- 4** Remove the cleaner.

EP Cover Removal

- 5 Remove the operator panel. (See [page 7-12.](#))

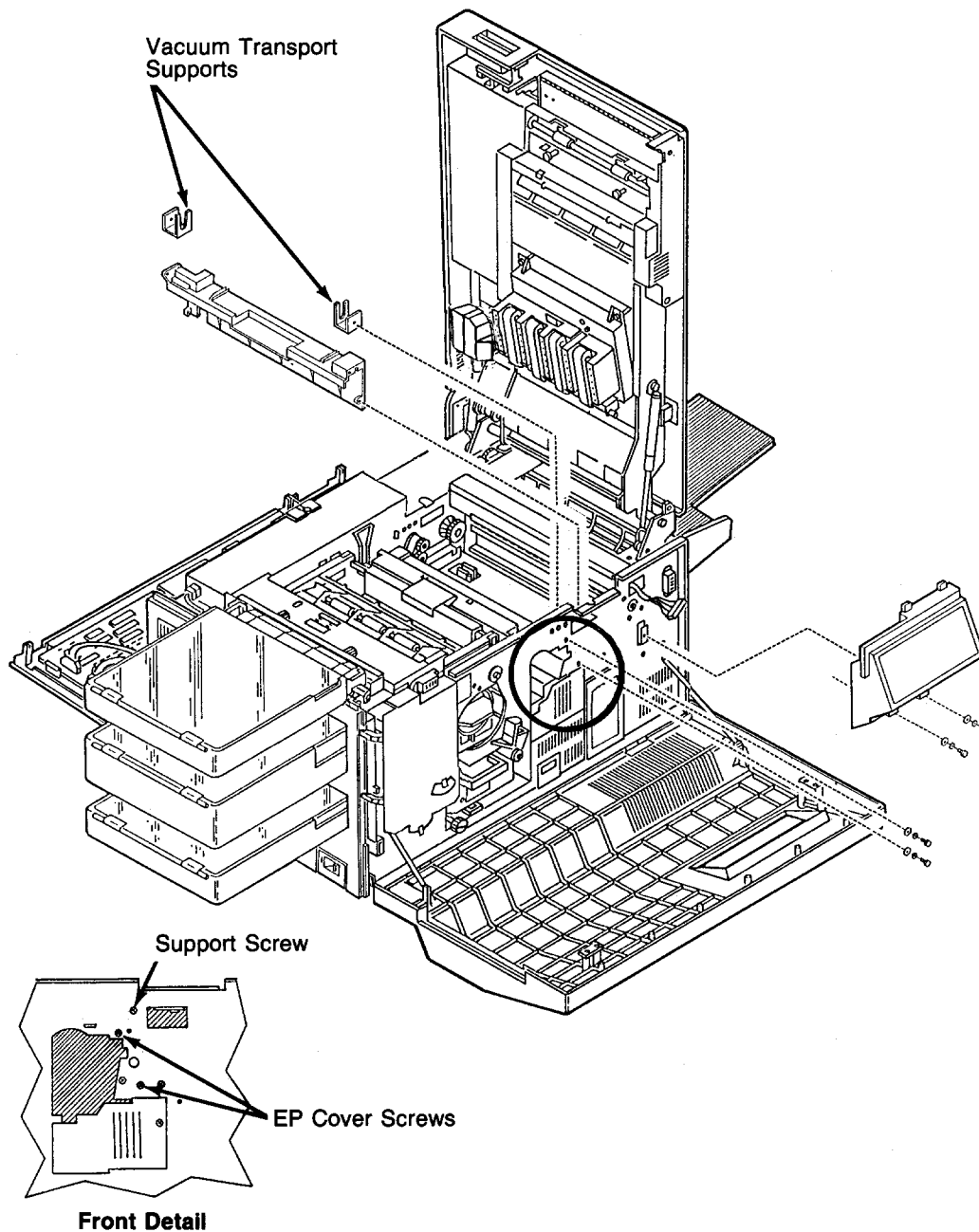

- 6 Remove the fuser drive cover (three screws).
- 7 Remove the two supports for the vacuum transport (one screw each).
- 8 Remove the four screws holding the EP cover in place (two front and two back).
- 9 Remove the upper right screw holding the fuser drive in place.

10 Lift the EP cover straight up out of the printer.

Replacement Note:

The higher of the two drive shaft support arms should be facing the left side of the printer.

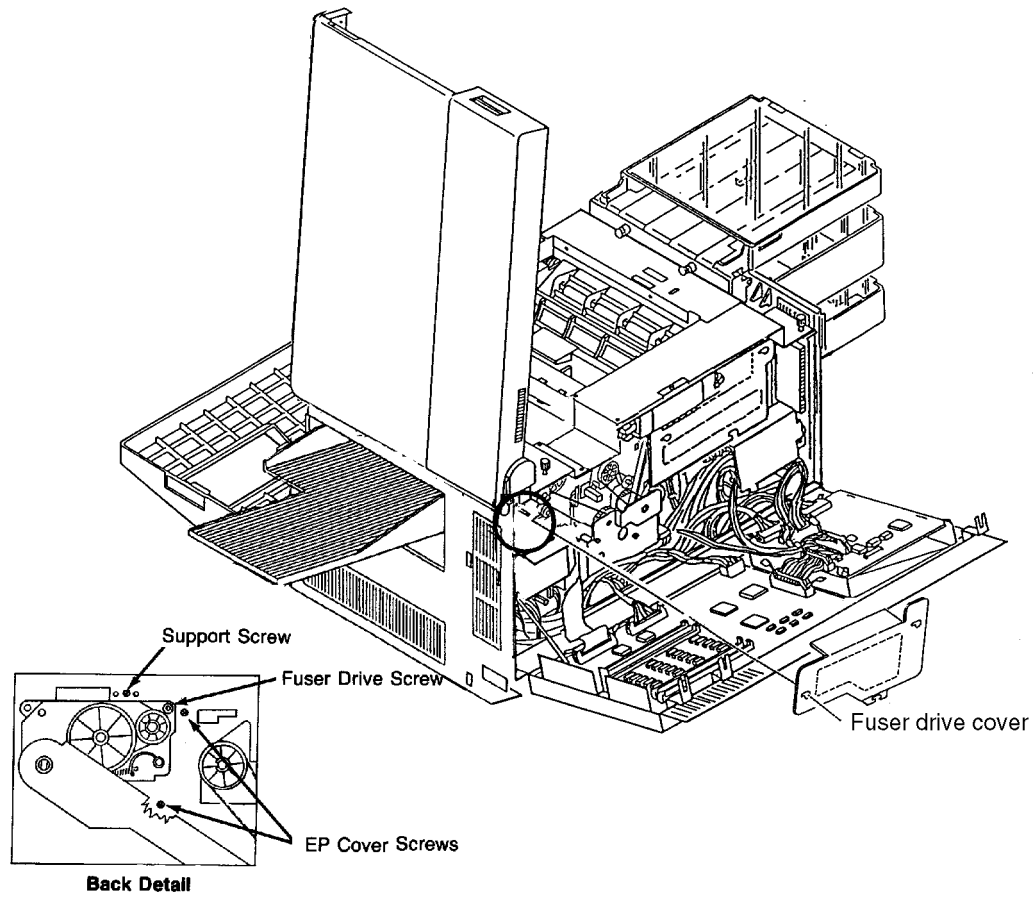

Main Motor Removal

Main Motor Removal

- 1 Disconnect all external cables and attachments.
- 2 Open the front, back, and top covers.
- 3 Remove the photoconductor and place in its protective packaging.
- 4 Remove the cleaner.
- 5 Remove the back cover. (See [page 7-6.](#))
- 6 Remove the right side cover. (See [page 7-8.](#))
- 7 Remove the counter. (See [page 7-13.](#))

- 8 Remove the main drive cover (one screw).

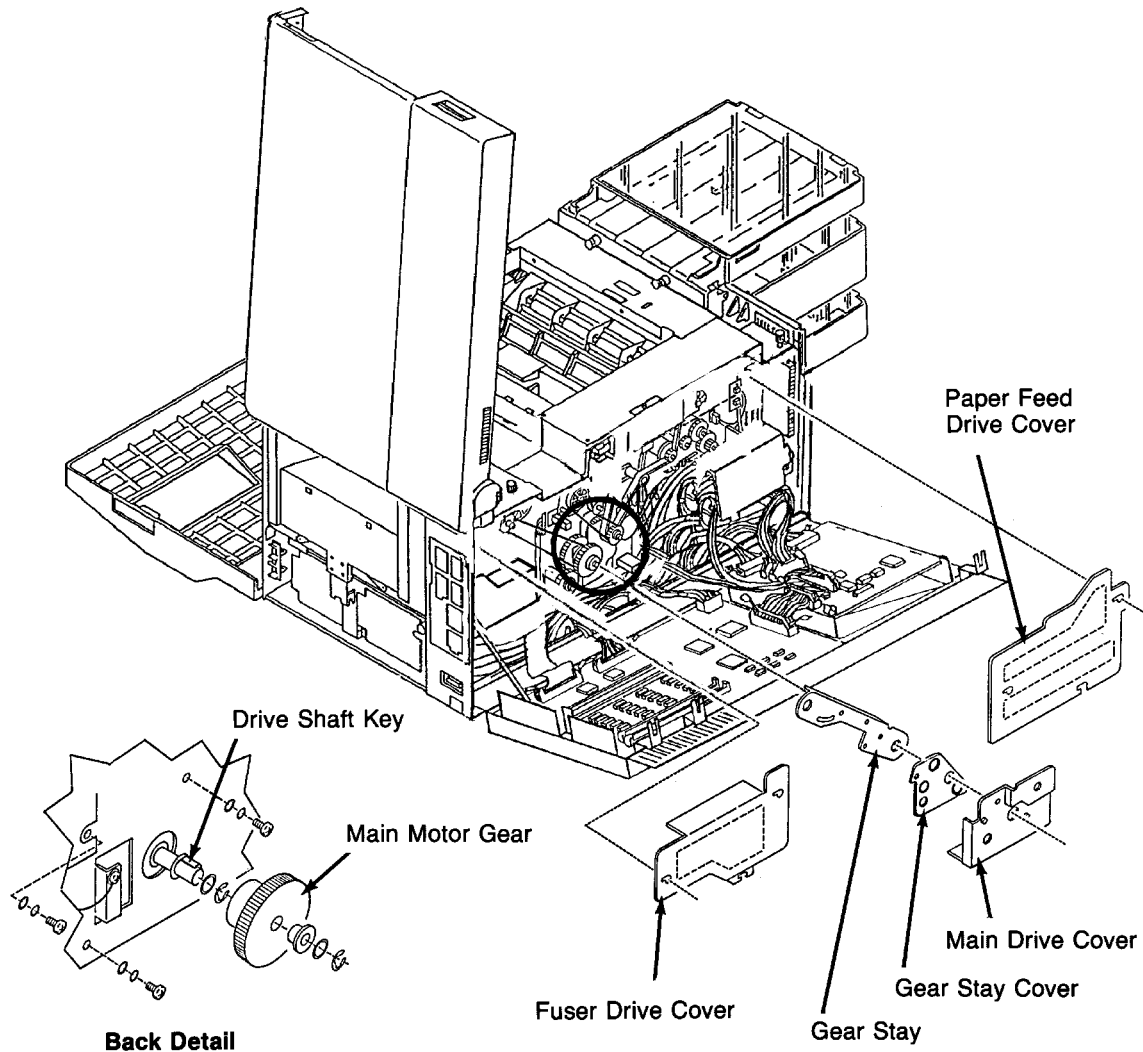

- 9 Remove the fuser drive cover (three screws).
- 10 Remove the gear stay cover.
- 11 Remove the gear stay (three screws).
- 12 Remove the hard disk drive housing. (See [page 7-19.](#))
- 13 Remove the printhead. (See [page 7-16.](#))
- 14 Remove the DC power supply. (See [page 7-26.](#))
- 15 Remove the main motor gear and bearing (two C-clips and a washer).

Main Motor Removal

- 16 Remove key, C-clip, and washer.
 - 17 Disconnect CN20 and remove the female end from the chassis.
 - 18 From the right side, remove the screw holding the D.C. main motor power supply in place.
 - 19 Remove the multicolored cable (PN2) from the D.C. main motor power supply.
 - 20 From the back, remove the three screws holding the main motor in place.
- Note:** Remove the lower screw first.
- 21 Remove the main motor through the side of the printer.

Replacement Notes:

Remove the drive shaft key from the old motor. Replacement motors are not supplied with a key.

Be sure to reroute CN20 after installation so that the wires do not protrude into the disk drive assembly area. Reroute the counter cable for the same reason.

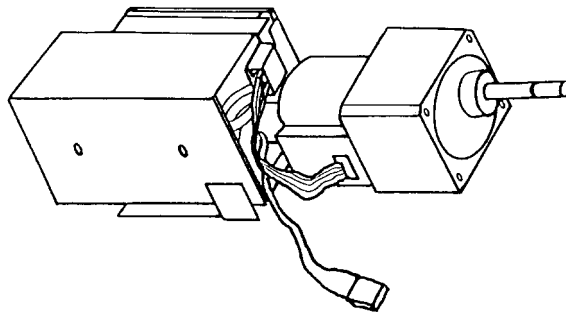

Main Gear Drive Removal

- 1 Open the back cover.
- 2 Remove the lower back cover. (See [page 7-6.](#))
- 3 Remove the paper feed drive cover (three screws).
- 4 Remove the fuser drive cover (three screws).
- 5 Remove the main drive cover (one screw).
- 6 Remove the gear stay cover (one screw).
- 7 Remove the gear stay (three screws).
- 8 Remove the cleaner drive belt. (See [page 7-51.](#))
- 9 Remove the paper feed drive belt. (See [page 7-55.](#))
- 10 Remove the main gear drive (three screws).

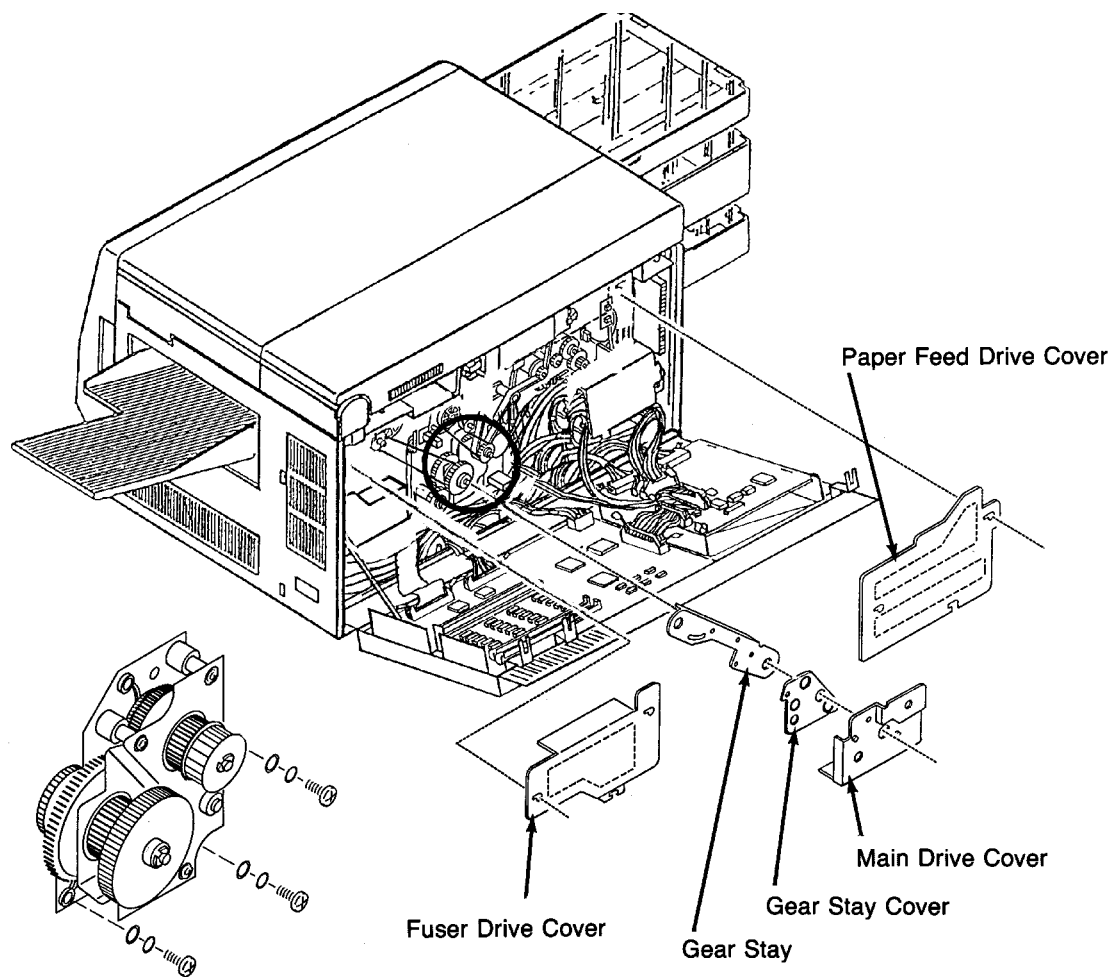

Main Gear Drive Detail

Duplex Control Board #1 Removal

Duplex Control Board #1 Removal

- 1 Open the top cover.
- 2 Remove the duplex control board cover (two screws).
- 3 Disconnect CN306, CN307, CN308, and CN309.
- 4 Disengage the duplex control board #1. To do this, pinch the four standoffs on the board, one at a time.
- 5 Lift the board from the mounting bracket.

Note: When reinstalling, make sure the duplex control board is pushed down towards the vacuum transport.

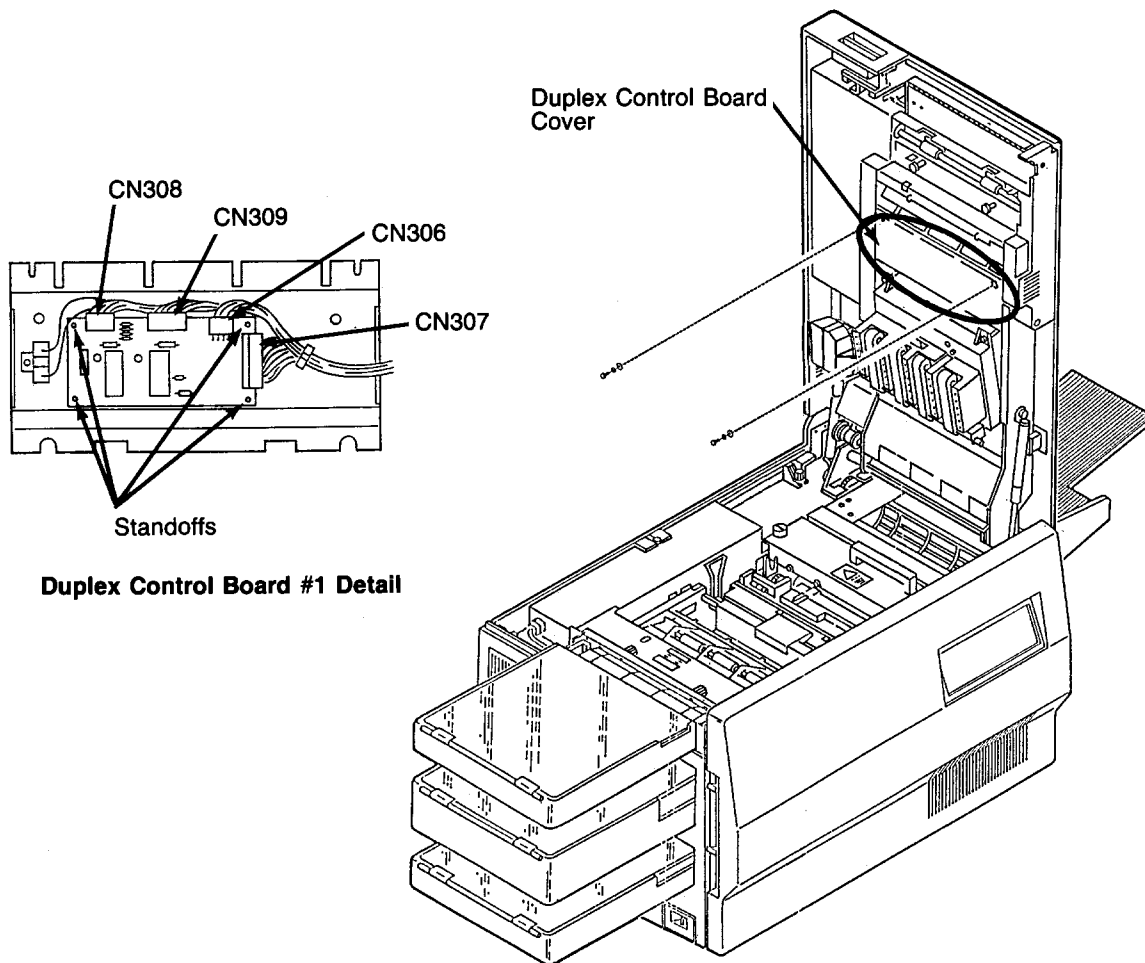

Duplex Control Board #2 Removal

- 1 Open the top cover.
- 2 Remove the duplex tray.
- 3 Remove the paper guide from the duplex tray (four screws).
- 4 Disconnect CN310, CN311, and CN312.
- 5 Remove duplex control board #2 (two screws).

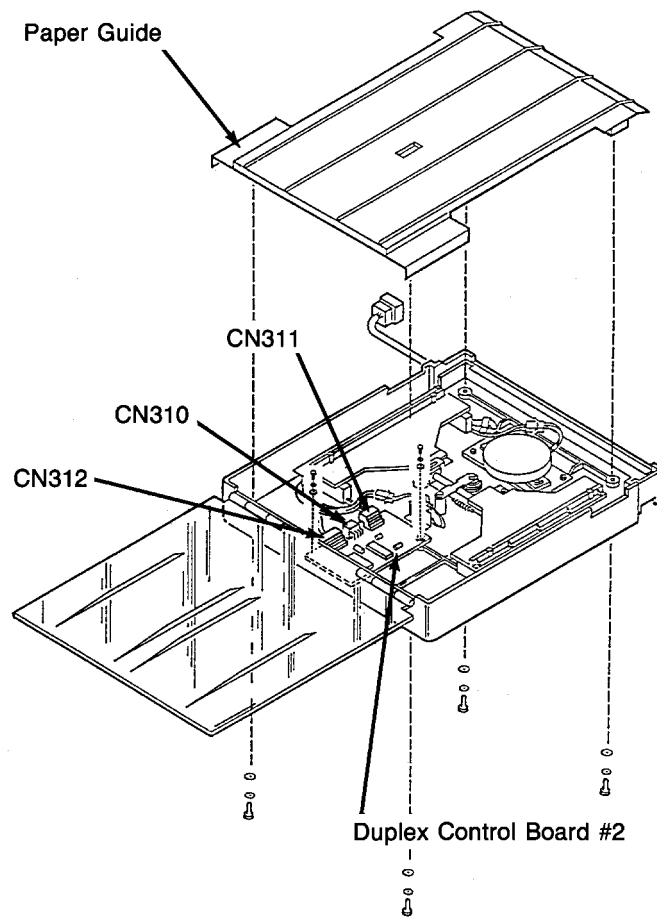

Duplex Tray Registration Motor Removal

Duplex Tray Registration Motor Removal

- 1 Open the top cover.
- 2 Remove the duplex tray.
- 3 Remove the paper guide inside the duplex tray (four screws).
- 4 Disconnect CN321.
- 5 Remove the registration motor (two screws).

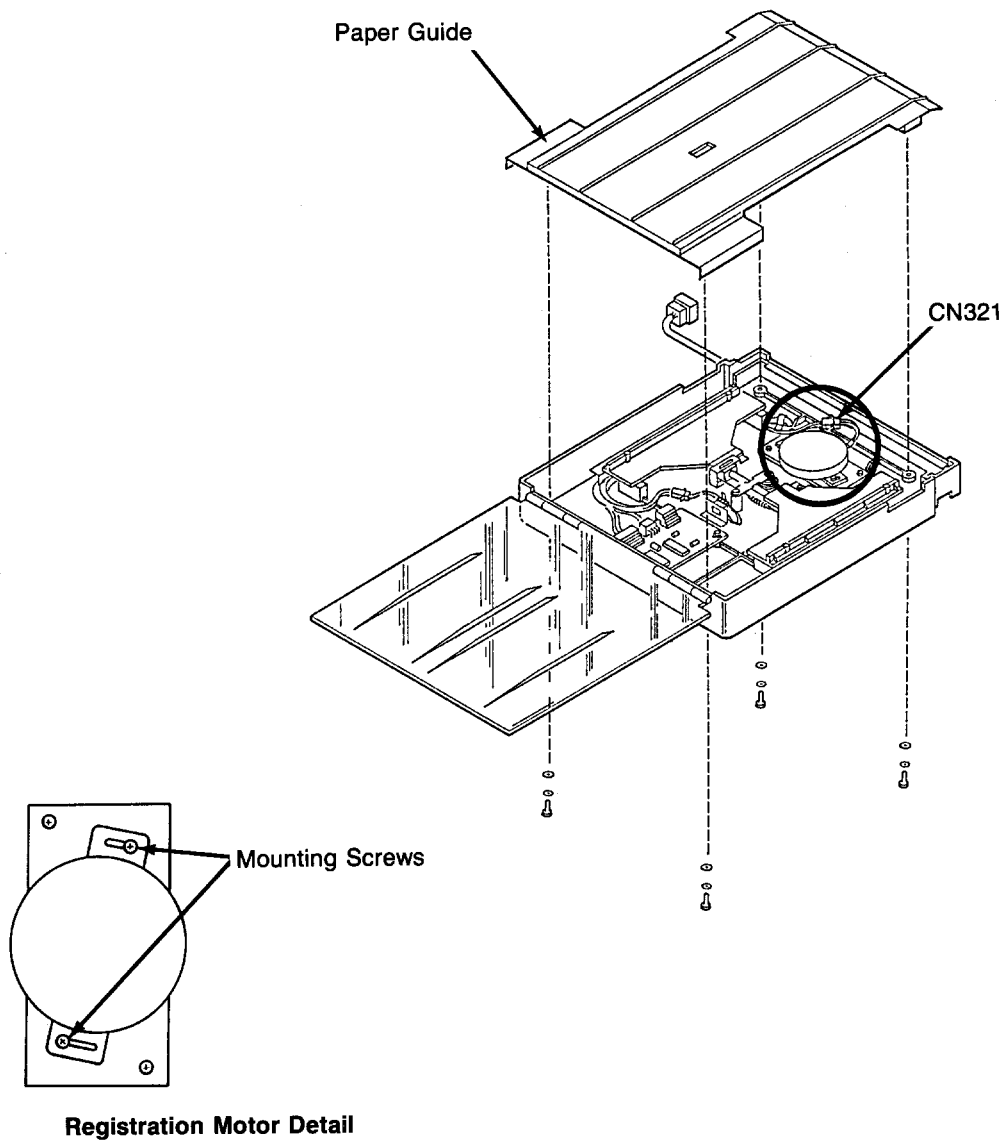

Duplex Skew Correction Cable Removal

- 1** Open the top cover. (See next page for illustration.)
- 2** Remove the duplex tray.
- 3** Remove the paper guide inside the duplex tray (four screws).
- 4** Slide the skew correction guides toward the center of the duplex tray.
- 5** Remove the bracket holding the shaft in place (two screws).
- 6** Remove the screw holding the cable mounting plate in place.
- 7** Lift the skew correction guides and shaft up out of the duplex tray.
- 8** Remove the two screws holding each pulley assembly in place.
- 9** Remove the spring from the cable.
- 10** Lift the skew correction cable and pulley assemblies from the duplex tray.

Replacement Notes:

The placement of the mounting bead is critical. Set it on precisely. Replace parts in this order:

- 1** Reinstall the pulley assembly first.
- 2** Then, wrap the cable three times around the drive gear pulley.
- 3** Finally, connect the spring.

Duplex Skew Correction Cable Removal

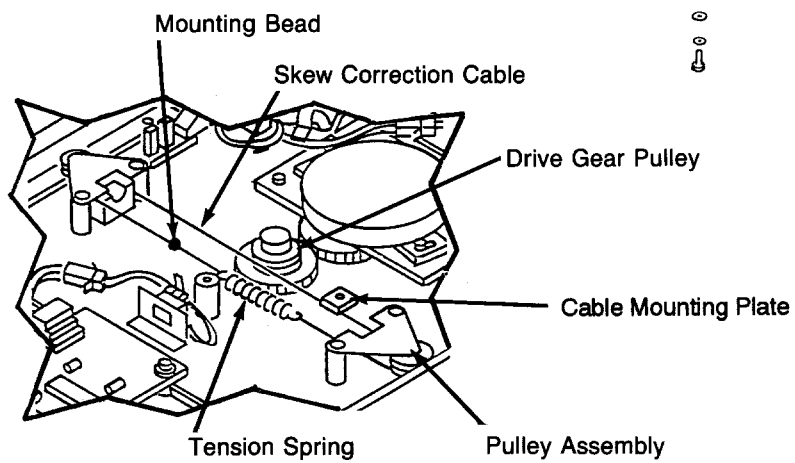
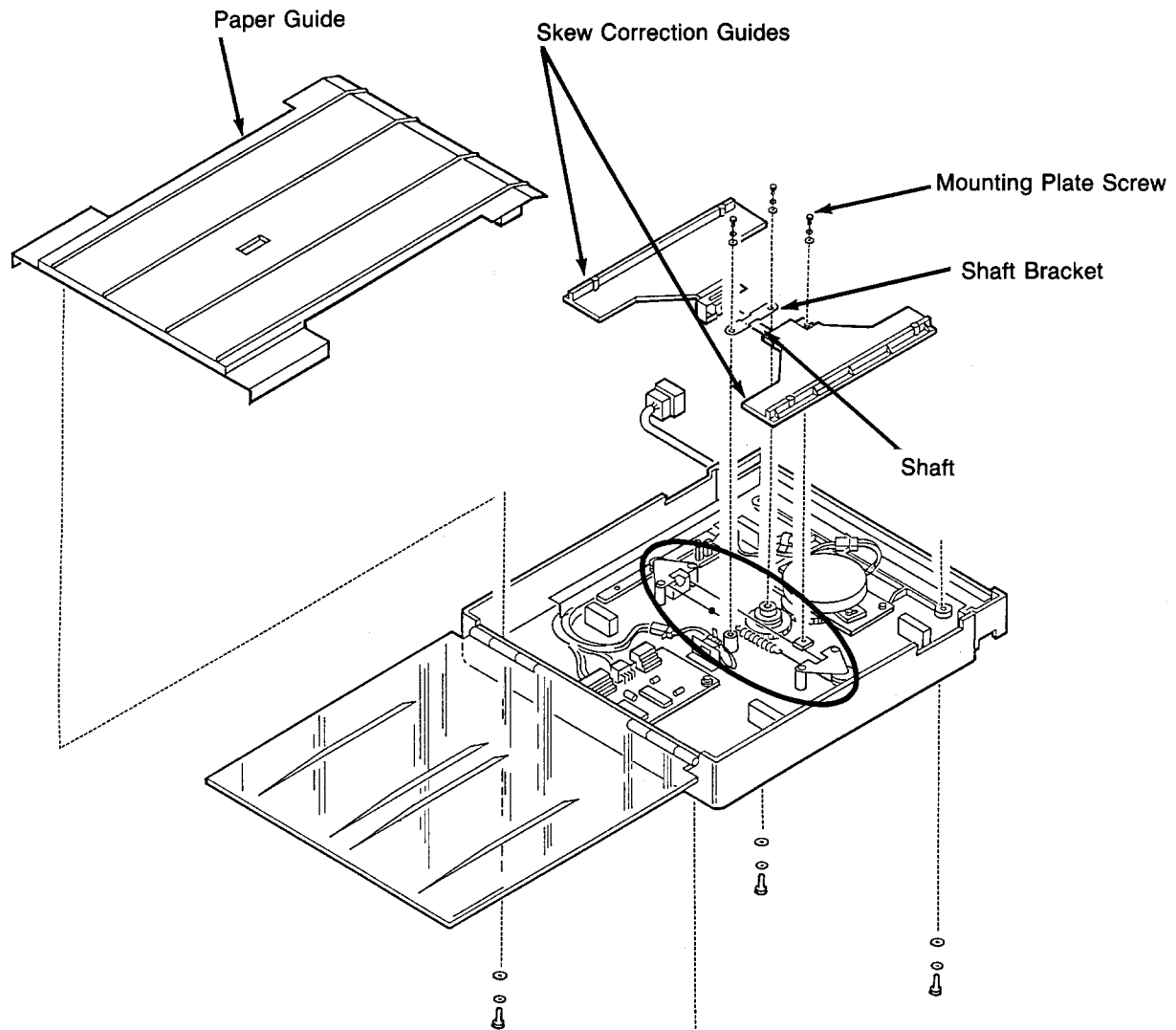

Skew Correction Cable Detail

Upper Duplex Drive/Clutch Assembly Removal

- 1 Open the top cover.
- 2 Remove the rear duplex cover. (See [page 7-10.](#))
- 3 Remove the lower duplex roller cover (four screws).
- 4 Disconnect CN316.
- 5 Remove the upper duplex drive/clutch assembly (three screws).

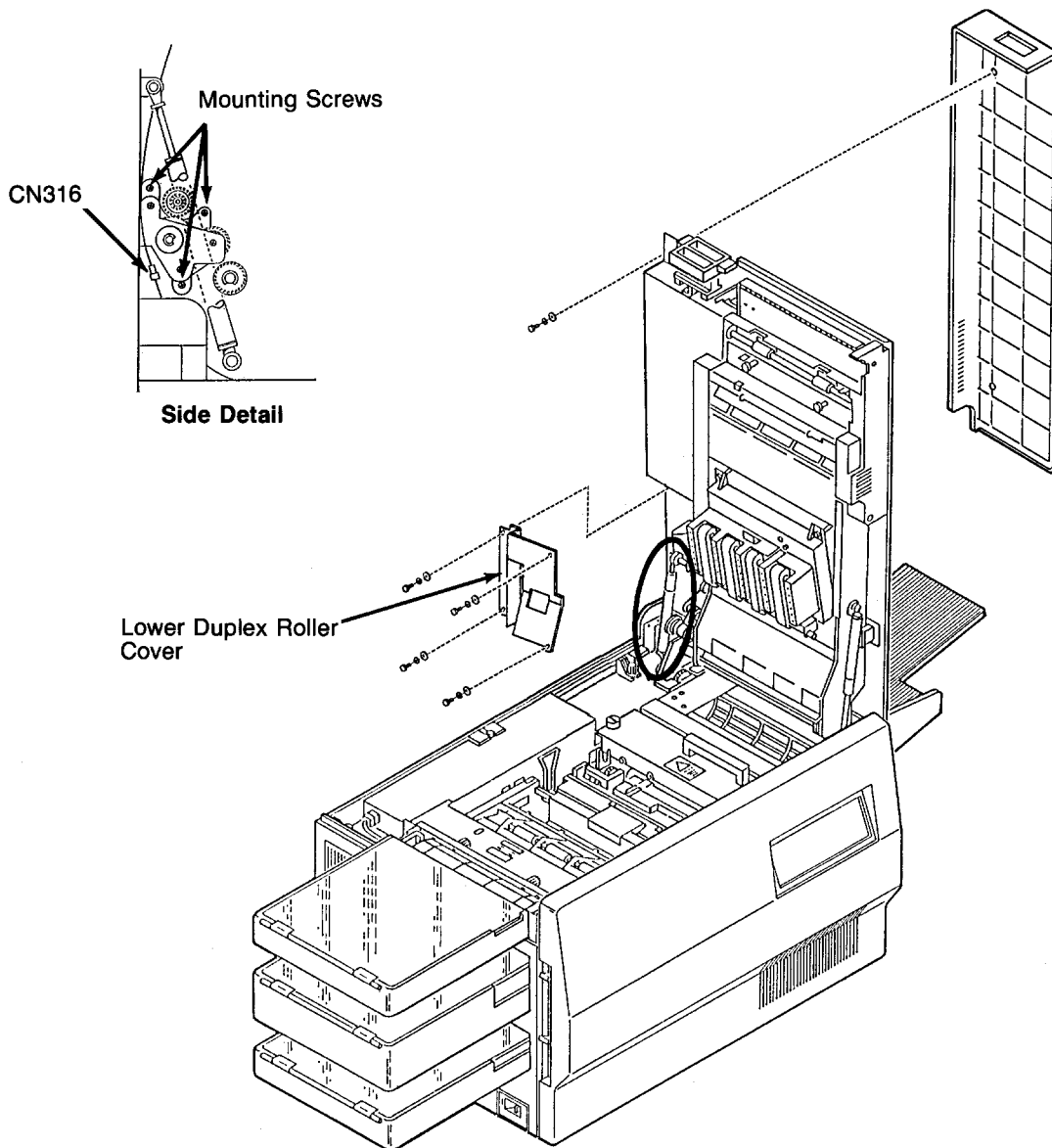

Duplex Route Motor/Solenoid Assembly Removal

Duplex Route Motor/Solenoid Assembly Removal

- 1 Open the top cover.
- 2 Remove the rear duplex cover. (See [page 7-10.](#))
- 3 Remove the upper duplex roller cover (four screws).
- 4 Disconnect CN313 and CN314.
- 5 Remove the duplex route motor/solenoid assembly (three screws).

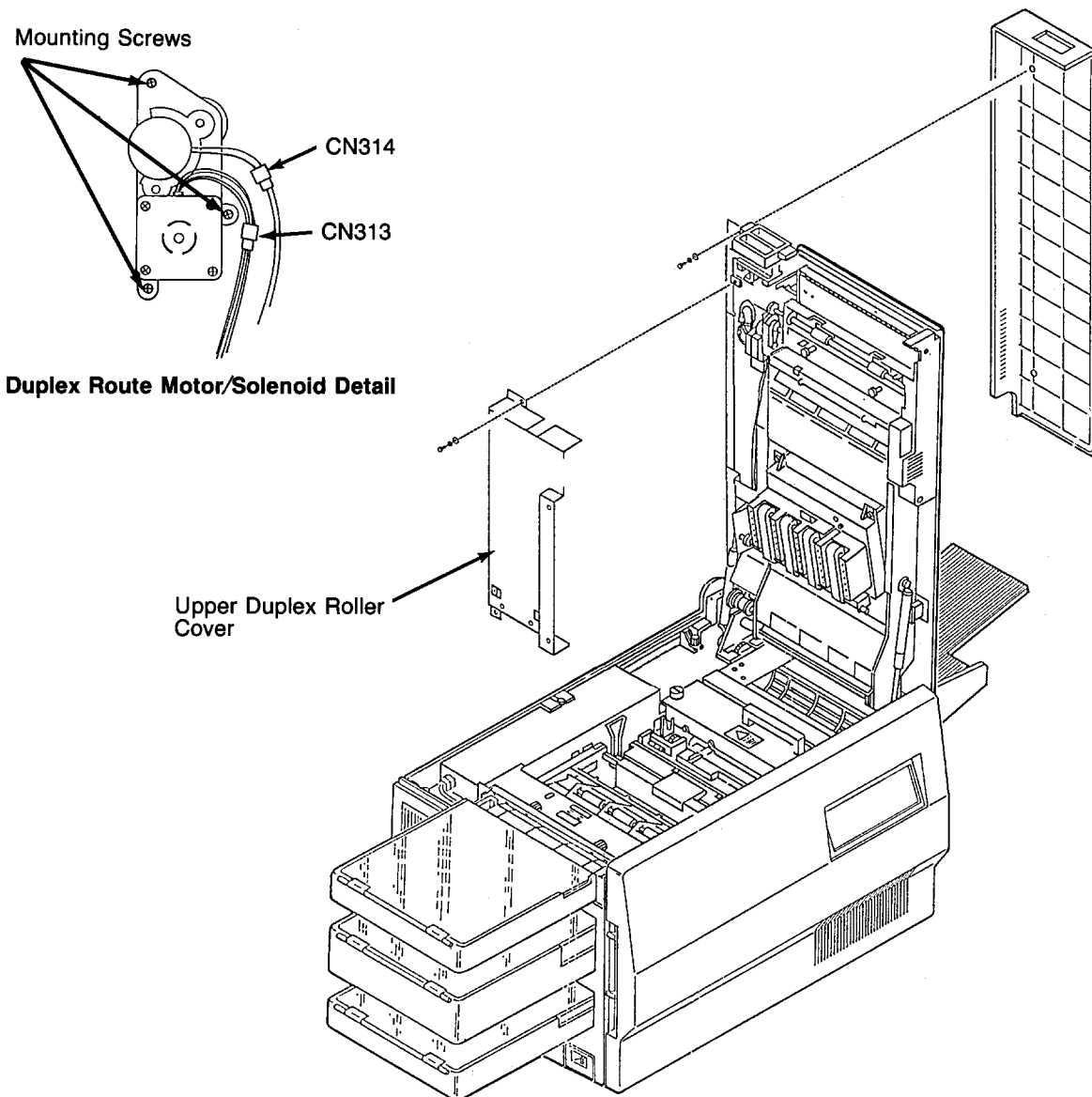

"A" Roller Removal

- 1 Open the top cover.
- 2 Remove the rear duplex cover. (See [page 7-10](#).)
- 3 Remove the lower duplex roller cover (four screws).
- 4 Remove the front C-clip and bearing from the "A" roller.
- 5 Lower the top cover to a 45-degree angle.
- 6 Slide the "A" roller out the back of the printer.

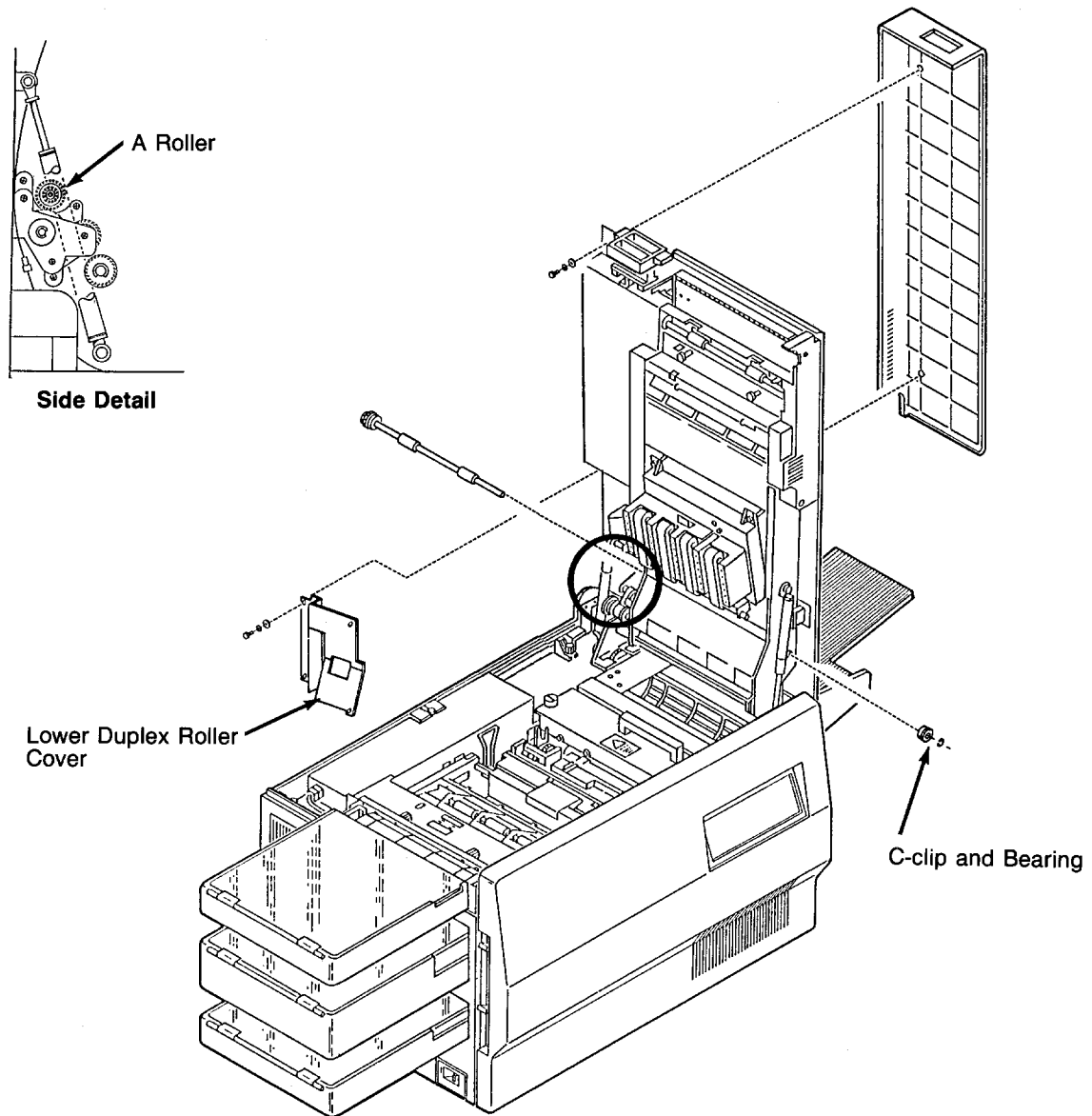

“B” Roller Removal

“B” Roller Removal

- 1** Open the top cover.
- 2** Remove the rear duplex cover. (See [page 7-10.](#))
- 3** Remove the upper duplex roller cover (four screws).
- 4** Remove the lower duplex roller cover (four screws).
- 5** Remove the front C-clip and bearing from the “B” roller.
- 6** Remove the two screws holding the duplex control board cover in place.
- 7** Move the cover to the left out of the way.
- 8** Loosen the screw holding the idler roller in place.
- 9** Remove the duplex drive belt.
- 10** Remove the drive gear (one C-clip).

11 Slide the "B" roller out the back of the printer.

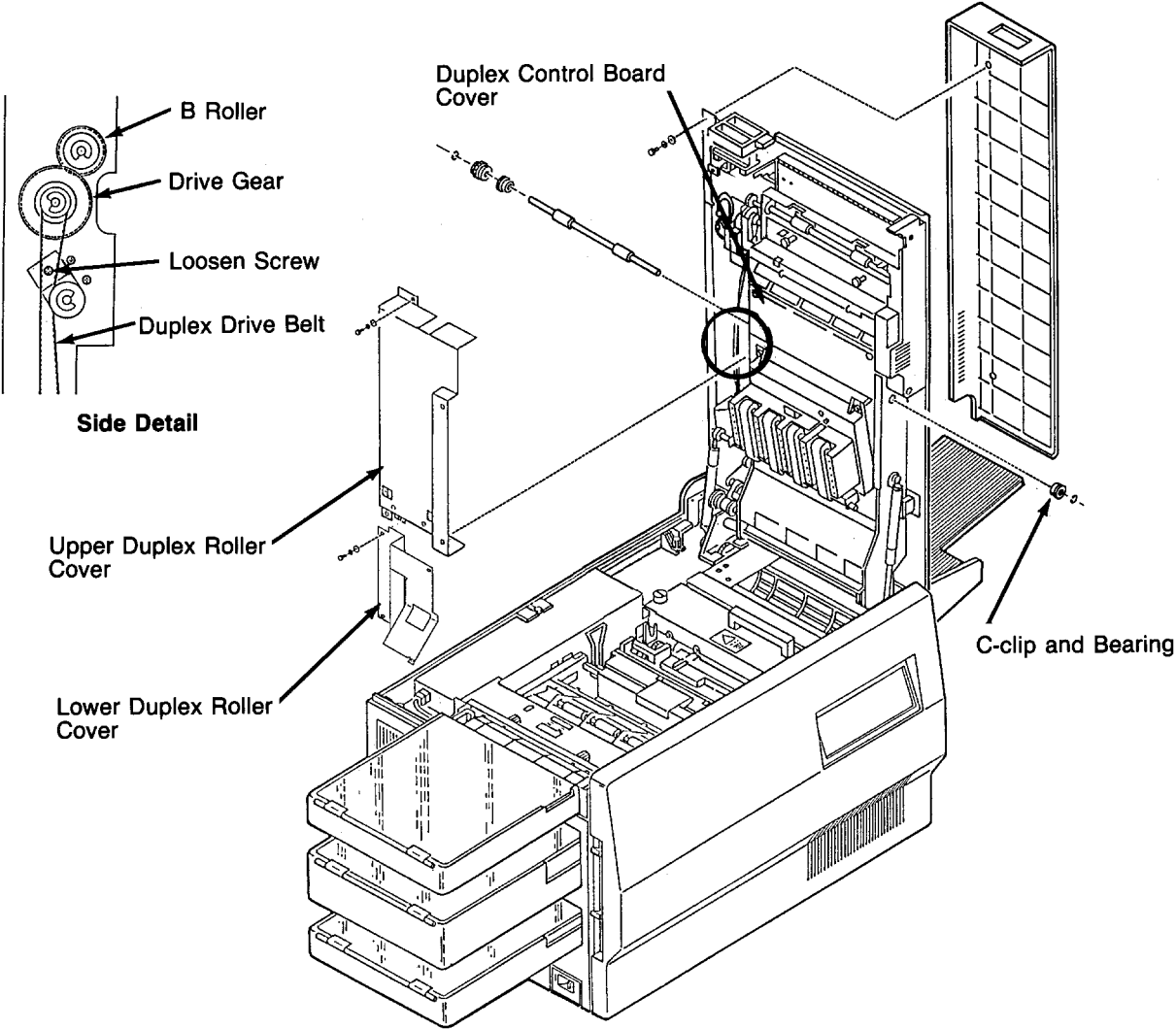

"C" Roller Removal

"C" Roller Removal

- 1 Open the top cover.
- 2 Remove the rear duplex cover. (See [page 7-10.](#))
- 3 Remove the upper duplex roller cover (four screws).
- 4 Remove the front mechanism cover (two screws).
- 5 Remove the front C-clip and bearing from the "C" roller.
- 6 Slide the "C" roller out the back of the printer.

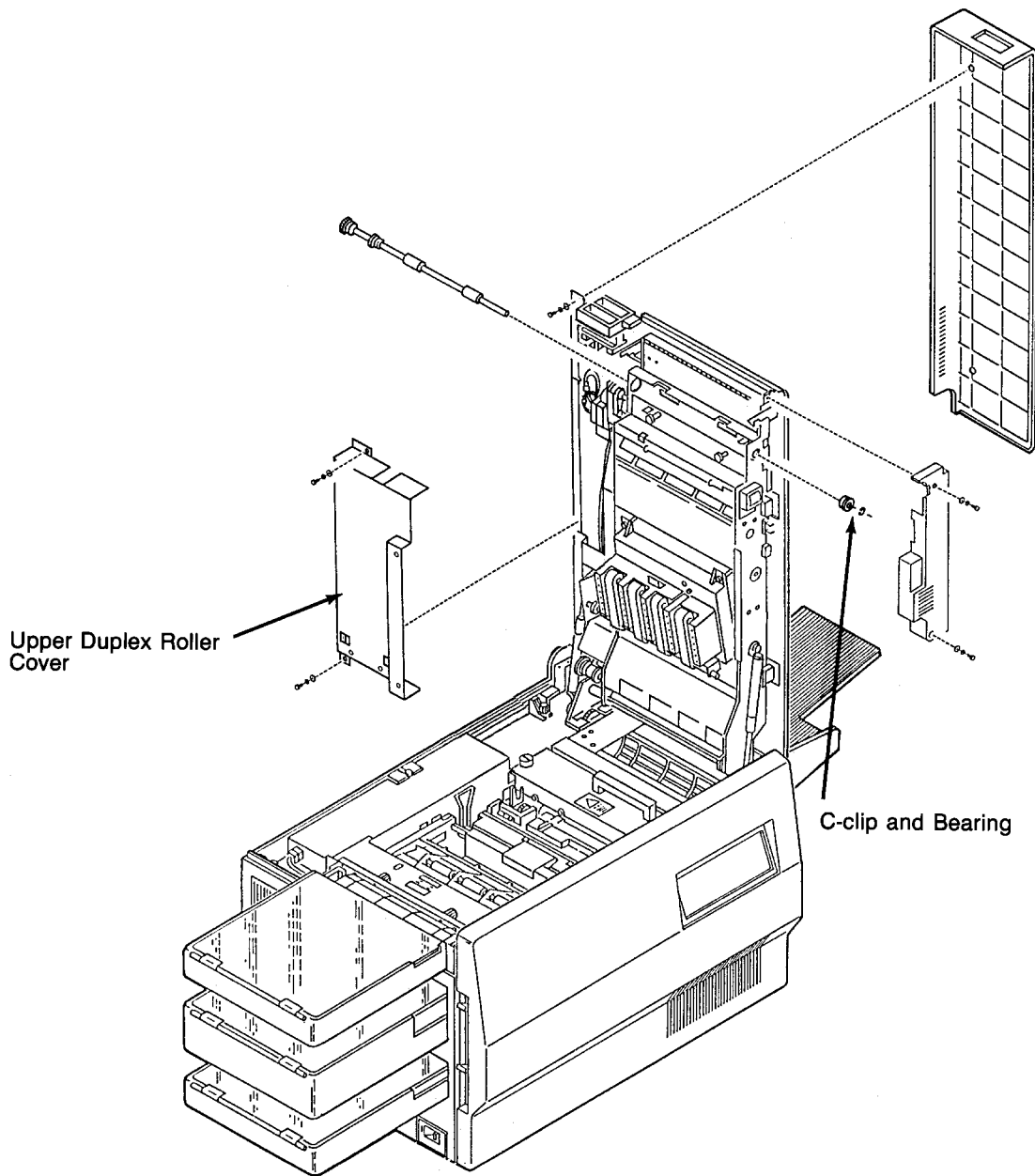

“C” Roller Solenoid Removal

- 1 Open the top cover.
- 2 Remove the front mechanism cover (two screws).
- 3 Disconnect CN315 and cut the cable tie securing the wires to the mounting plate.
- 4 Remove the two screws holding the “C” roller solenoid in place.
- 5 Loosen the set screw securing the actuator arm to the “C” roller.
- 6 Disengage the solenoid from the actuator arm and remove it.

Replacement Note:

Install a new cable tie to secure the wires from CN315 to the mounting plate.

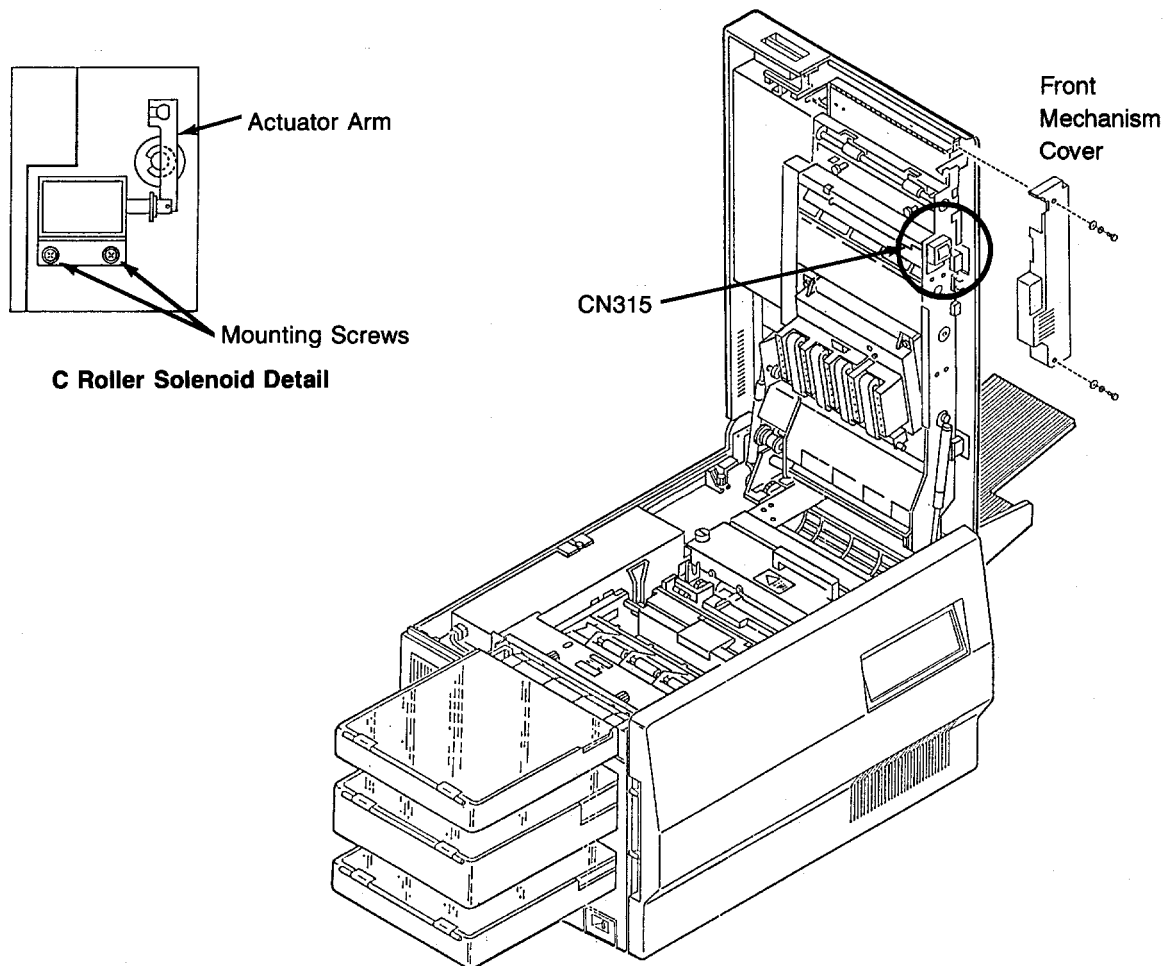

Duplex Route Separator Removal

- 1 Open the top cover.
- 2 Remove the rear duplex cover. (See [page 7-10.](#))
- 3 Remove the upper duplex roller cover (four screws).
- 4 Remove the duplex route motor/solenoid assembly. (See [page 7-92.](#))
- 5 Remove the front mechanism cover (two screws).
- 6 Open the duplex cover.
- 7 Remove the screw holding the return arm in place.
- 8 Disengage the return spring.
- 9 Remove the front C-clip from the route separator.
- 10 Disengage the route separator from its side supports.
- 11 Lift the route separator out from the duplex cover.

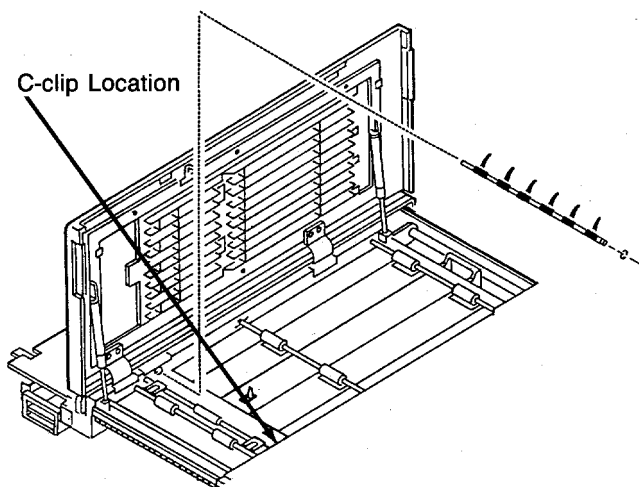

Duplex Paper Path Sensor Removal

- 1 Open the top cover.
- 2 Remove the two screws holding the duplex control board cover in place.
- 3 Move the cover to the left out of the way.
- 4 Disconnect CN319.
- 5 Remove the duplex paper path sensor (one screw).

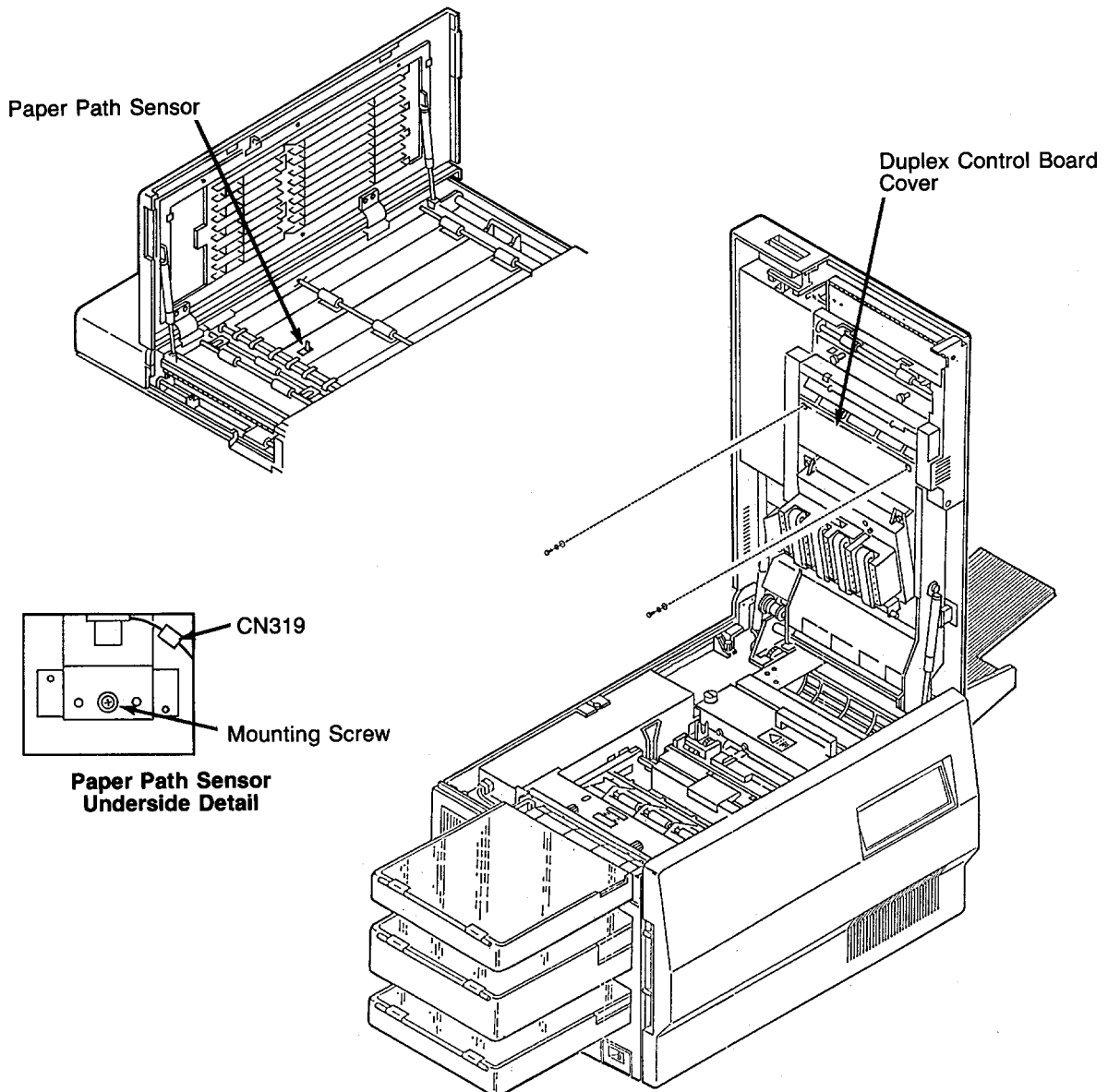

Duplex Paper Path Sensor Removal

Section 8

Options

Contents

Options

| | |
|--|------|
| Introduction | 8-3 |
| 1200-Sheet/2500-Sheet Feeder..... | 8-4 |
| Guide to Component Acronyms/Physical Locations..... | 8-4 |
| Bench Test Procedure | 8-5 |
| Connection Diagram for 1200-Sheet /2500-Sheet Feeder | 8-8 |
| Prefeed Adjustment Procedure | 8-7 |
| 1200-Sheet Feeder Only | 8-7 |
| 2500-Sheet Feeder Only | 8-7 |
| Input Control Board Logic | 8-9 |
| 1400-Sheet Stacker | 8-10 |
| Guide to Component Abbreviations/Physical Locations..... | 8-10 |
| Bench Test Procedure | 8-11 |
| Connector Locations..... | 8-13 |
| Front View (cover removed) | 8-13 |
| Left Side View (left cover removed) | 8-13 |
| Rear Side View (cover removed) | 8-14 |
| Top View (top cover removed) | 8-14 |
| Connection Diagram for the 1400-Sheet Stacker | 8-15 |
| Output Control Board Logic | 8-16 |

Section 8

Options

Introduction

This section provides information about troubleshooting and testing specific printer options not covered elsewhere in the manual. These options include the 1200- and 2500-sheet High Capacity Input (HCI) units, and the 1400-sheet High Capacity Output (HCO) unit.

Installation instructions for the sheet feeders and sheet stacker are in the *C40D Installation Manual*, which is shipped with the C40D.

For a complete list of the parts contained in the 1200-sheet feeder, the 2500-sheet feeder, and the 1400-sheet stacker, please see the Illustrated Parts Catalog.

1200-Sheet/2500-Sheet Feeder

Guide to Component Acronyms/Physical Locations

| Acronym | Component |
|---------|--|
| DSW | Door Switch (magnetic door lock) |
| IEM | Input Elevator Motor (M1 - elevator motor) |
| ILLS | Input Lower Limit Sensor |
| IPES | Input Paper Tray Sensor |
| IPM | Input Pick-up Motor (M2 - paper pick-up motor) |
| IULS | Input Upper Limit Sensor |
| NF | AC Noise Filter |
| NPS | No Paper Solenoid |
| PCSW | Power Control Switch (slope tray interlock switch) |
| PES | Paper End Sensor |
| PHS | Paper Head Sensor |
| SOL | Solenoid |

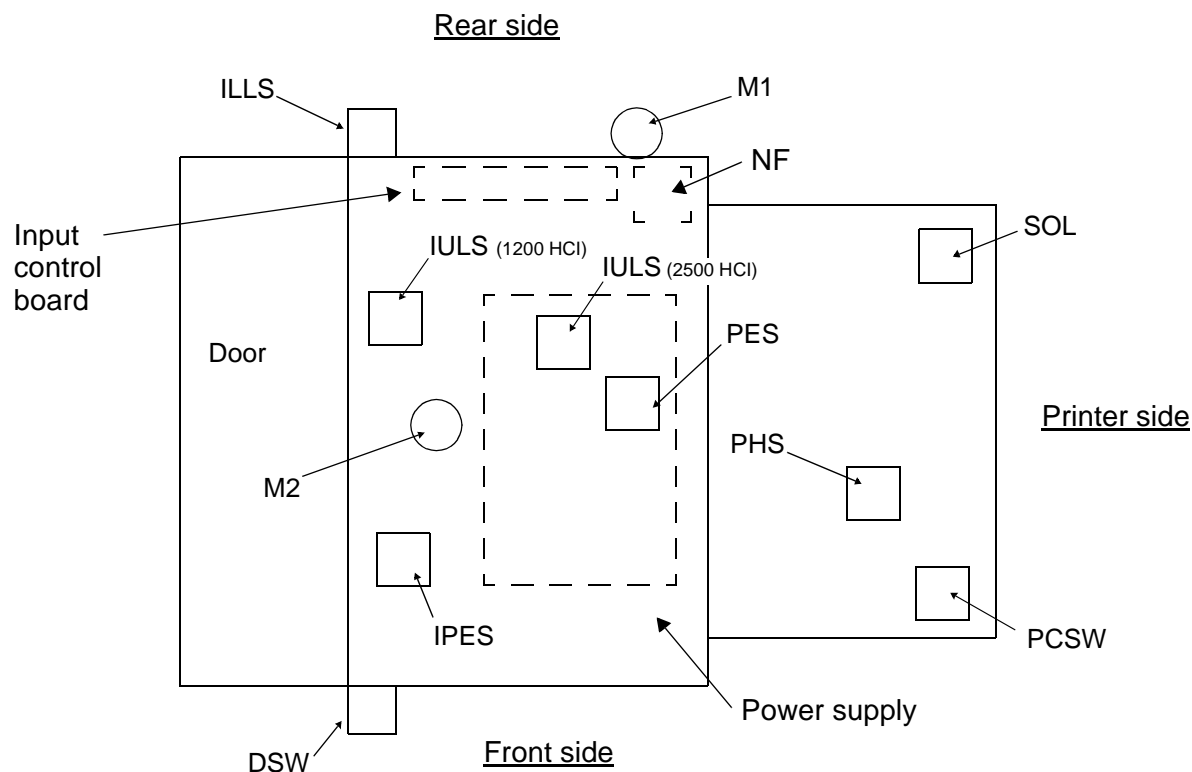

Bench Test Procedure

- 1** Turn the printer's main power switch off, then disconnect the unit's power cord.
- 2** Press down the printer's lower cassette release lever, then remove the unit from the printer and place it on a work bench or other suitable surface.
- 3** Remove the paper size lever, then lift up the slope tray and place the lever between the slope tray and the frame. This will bypass the interlock switch (PCSW) located under the slope tray, allowing 12Vdc to be applied to the input control board.
- !** The slope tray is normally lifted into operating position by the printer's lower paper lift arm.

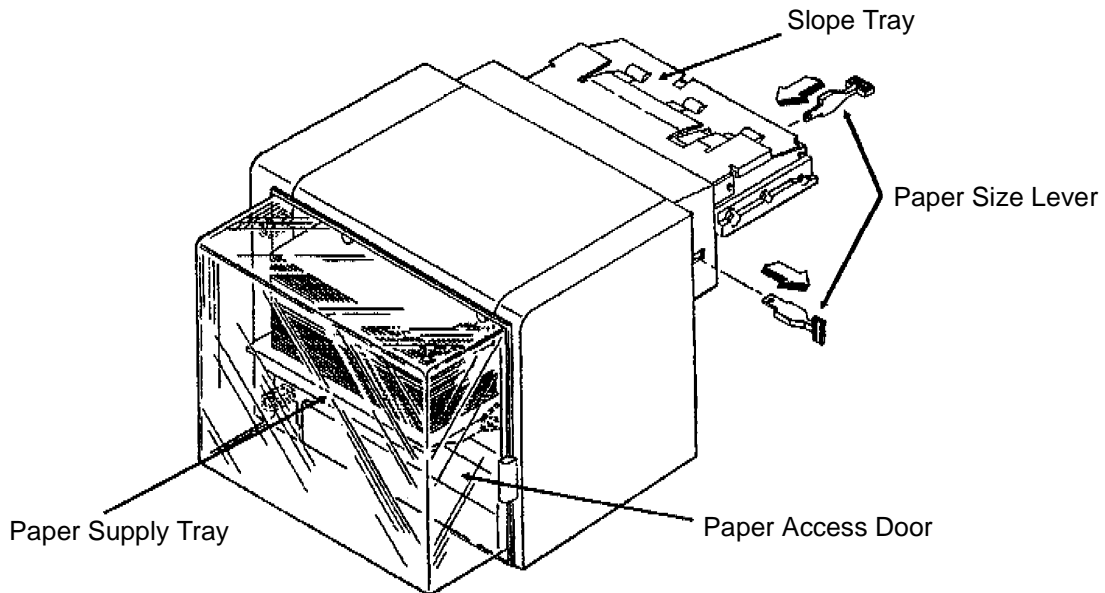

- 4** Restore AC power to the unit (either the unit's power cord or the printer's power cord may be used).
- 5** Open the paper access door. The elevator motor (M1) should turn on, moving the paper stock down. There is an actuator attached to the elevator's chain drive that will activate photosensor ILLS signalling the input control board that the paper supply tray is completely down.
- !** Remove any paper that may be on the unit's slope tray.

Bench Test Procedure

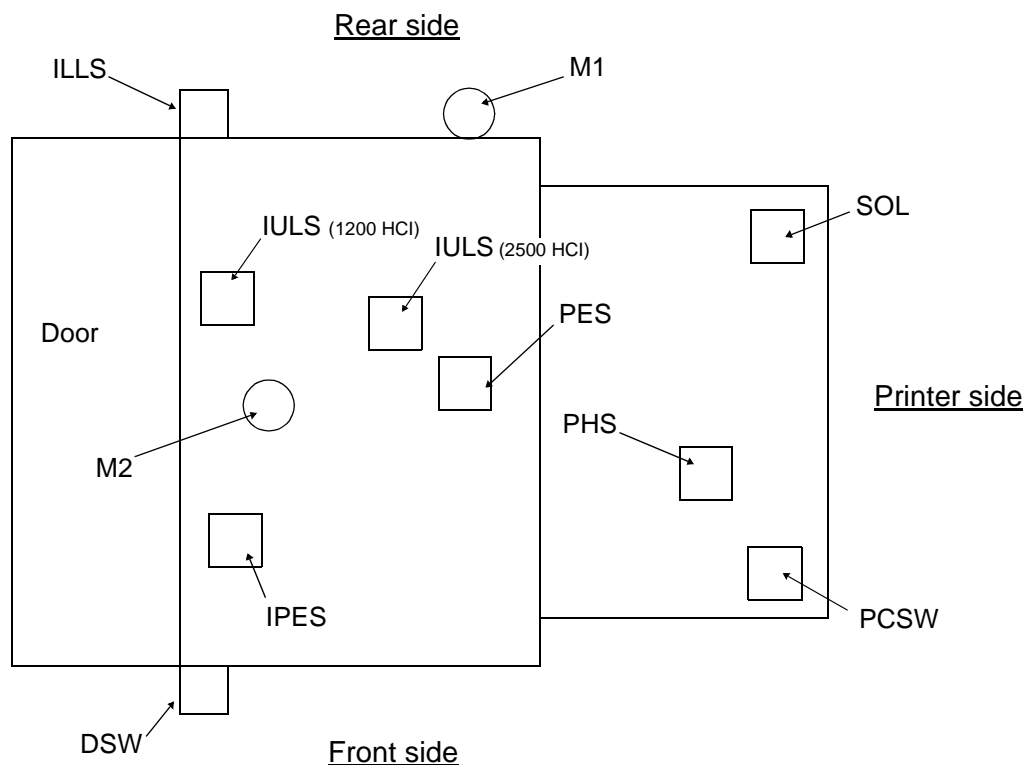

- 6** Close the paper access door. The elevator motor (M1) should turn on, moving the paper stack up. There are two actuators that must enable two photosensors. Photosensor IPES signals the input control board that paper is present on the elevator. Photosensor IULS signals the input control board that the upper limit for the paper supply tray and paper stack has been reached.
- 7** With the paper supply tray all the way up and with no paper present on the slope tray (indicated to the input control board by photosensor PES, located in the middle of the paper path), the pick-up roller assembly motor (M2) will turn on and transport a piece of paper to the slope tray.
- 8** When the paper is transported to the slope tray, note that the (SOL) solenoid (under the slope tray) energizes.
- !** The solenoid causes contact with the printer's paper present sensor.
- 9** By removing the piece of paper from the slope tray, photosensor PHS signals the input control board to turn the pick-up motor (M2) on to replace the piece of paper that was removed.
- 10** When the last sheet of paper has been fed from the paper supply tray to the slope tray, the actuator arm of photosensor IPES falls through a hole in the paper supply tray. This signals the input control board to turn the elevator motor (M1) on to move the paper supply tray down. The paper supply tray will remain down until the paper access door is reopened (more paper is loaded), then closed.
- 11** When the last sheet of paper has been removed from the slope tray, confirm that the solenoid (SOL) de-energizes.

Prefeed Adjustment Procedure

- ! This procedure should only be done if you are replacing the control board or experiencing excessive paper jams.
- 1 Remove the side, top, and throat covers from the unit.
- 2 Disconnect J509.
- 3 Using the bench test procedure, feed paper to the slope assembly.
- 4 Set VR2 fully counter clockwise.

1200-Sheet Feeder Only

- Adjust VR1 so that the paper feeds to 20 to 30 mm (approximately 1 inch) past the bend of the slope assembly.

2500-Sheet Feeder Only

- Adjust VR1 so that the paper feeds to 10 mm (approximately 3/8-inch) before the bend of the slope assembly.

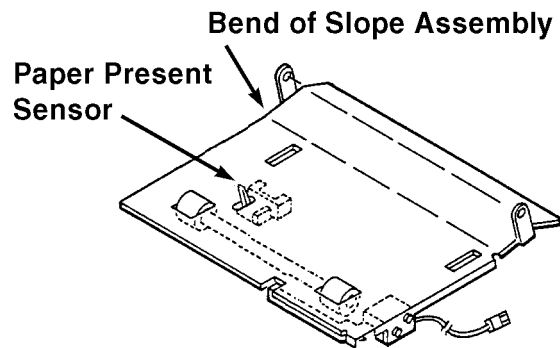

Connection Diagram for 1200-Sheet/2500-Sheet Feeder

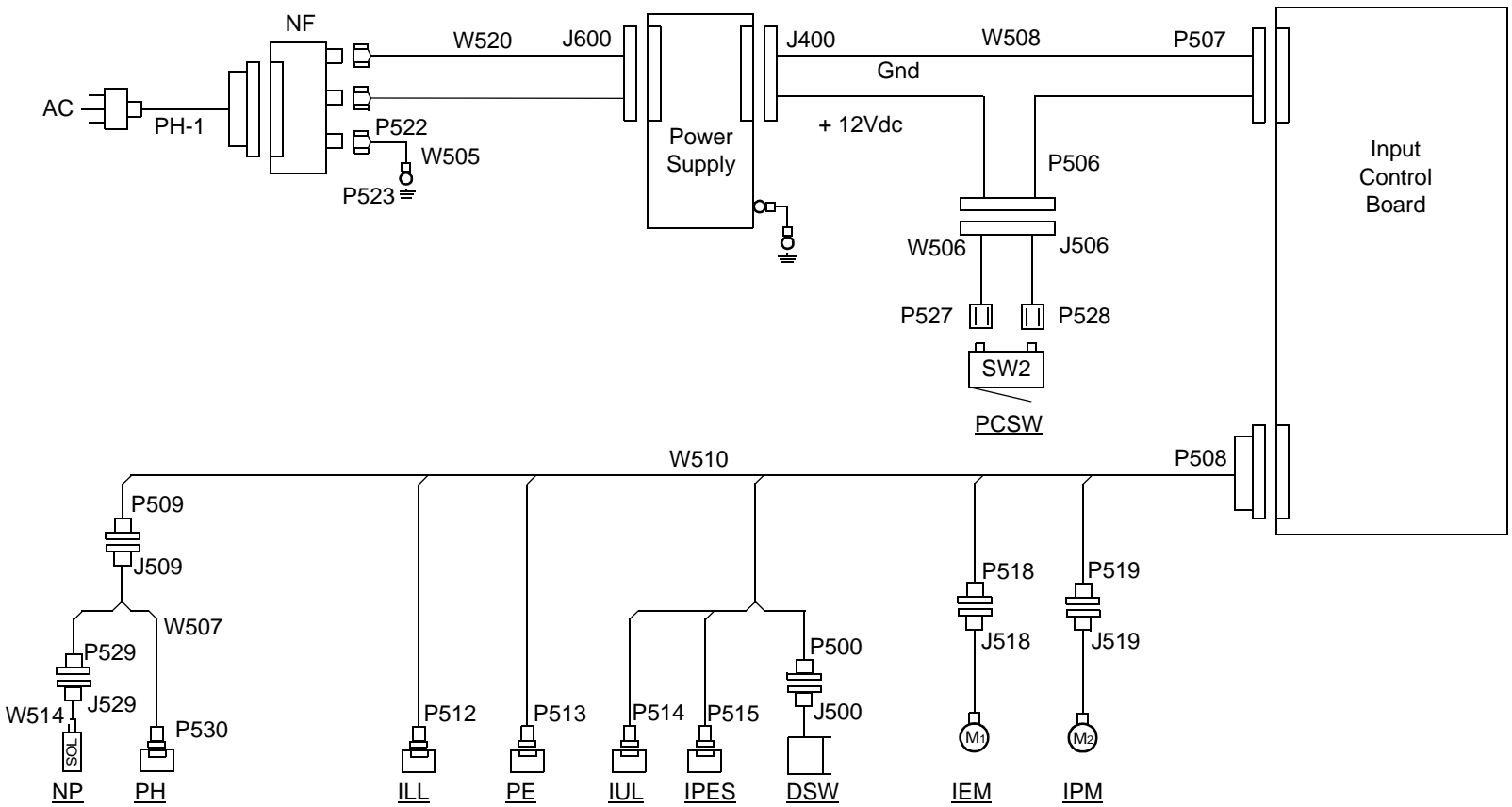

Input Control Board Logic

The table below indicates switching logic for the unit's various components. Except for the power control switch (PCSW), each component can be monitored from the various pins of CN508 (located on the input control board).

! When performing these checks, use test point TP 1 (located below CN507 on the input control board).

| Connector | Component | Monitored | Condition |
|--------------|-----------|-----------------|-----------------------------------|
| CN508-4 | PHS | High Low | Paper present No paper present |
| CN508-13 | PES | Low High | Paper present No paper present |
| CN508-19 | IPES | High Low | Paper present No paper present |
| CN508-16 | IULS | Low High | Limit No Limit |
| CN508-21 | DSW | High Low | Door open Door closed |
| CN508-10 | ILLS | High Low | Limit No limit |
| CN508-2 | NPS | High Low | On Off |
| CN508-25, 26 | IPM (M2) | +12Vdc 0Vdc | Feed No feed |
| CN508-23 | IEM (M1) | +12 Vdc 0Vdc | Up Off |
| CN508-24 | IEM (M1) | +12 Vdc 0Vdc | Down Off |
| CN507-2 | PCSW | 0Vdc +12Vdc | Unit mounted Unit not mounted |

1400-Sheet Stacker

Guide to Component Abbreviations/Physical Locations

| Abb | Component |
|------|------------------------------|
| ERM | Exit Roller Motor (M1) |
| EPS | Exit Paper Sensor |
| ERS | Exit Roller Sensor |
| OEM | Out Elevator Motor (M2) |
| OELS | Out Elevator Limit Sensor |
| OEPS | Out Exit Paper Sensor |
| OJFM | Out Jogging Front Motor (M4) |
| OJFS | Out Jogging Front Sensor |
| OJRM | Out Jogging Rear Motor (M3) |
| OJRS | Out Jogging Rear Sensor |
| OLLS | Out Lower Limit Sensor |
| OULS | Out Upper Limit Sensor |

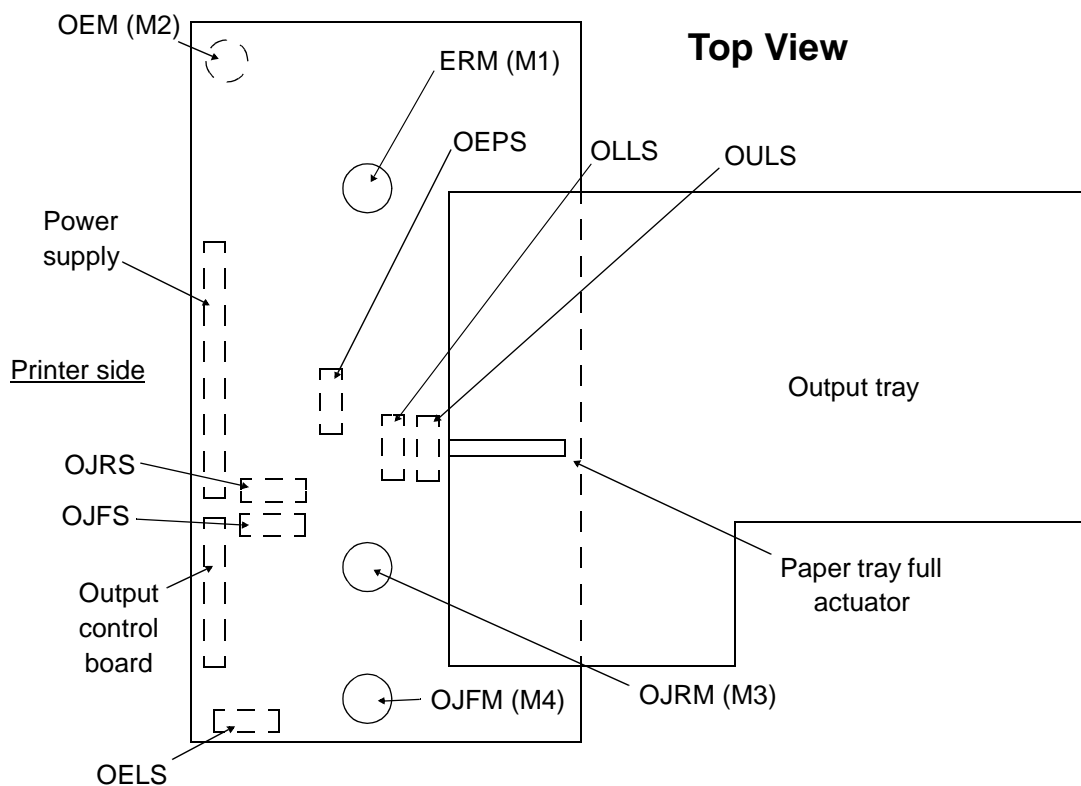

Bench Test Procedure

- 1 Turn the printer's main power switch off.

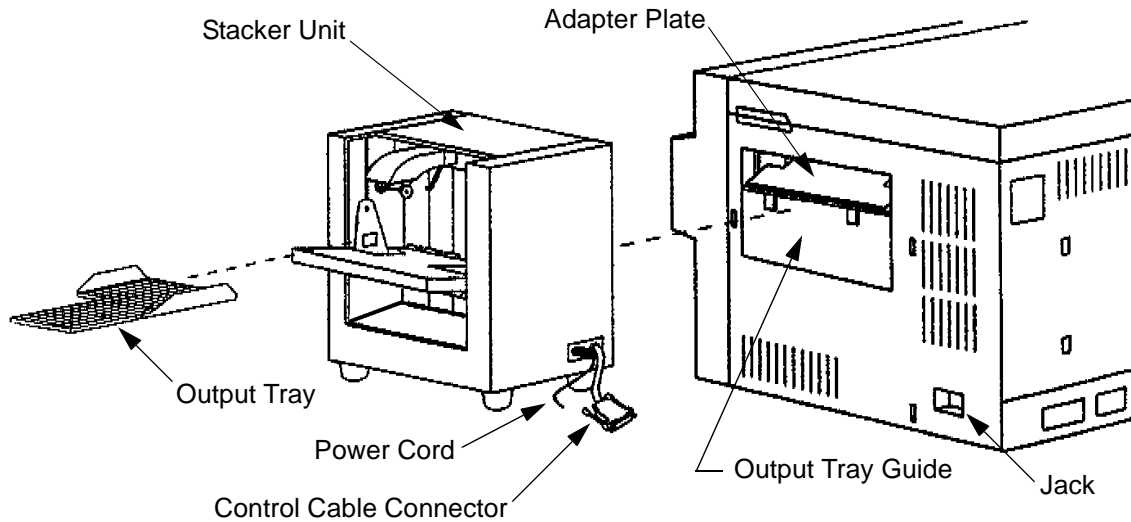

- 2 Remove the output tray from the stacker unit.
- 3 Disconnect the stacker unit's power cord from the printer and from the stacker, then disconnect the unit's control connector cable from the printer's jack.
- 4 Remove the stacker unit from the printer, then place it on a work bench or other suitable surface.
- 5 Remove the printer's power cord from the wall outlet and the printer's lower back cover.
- 6 Observe the pin configuration of the stacker unit's control connector cable plug (shown opposite page).
- 7 Place a jumper from pin 9 to pin 10 (ground). Using the printer's power cord in place of the unit's power cord, plug the printer's power cord in the stacker unit, then into the wall outlet.
- 8 With the power applied to the stacker unit, the exit roller motor (ERM-M1) will be off. This will signal the output control board to turn the exit roller motor (ERM-M1) on.
- 9 Remove the jumper from pin 9 and pin 10.
- 10 Lift the paper tray full actuator to enable photosensor OLLS to signal the output control board to cause the elevator motor (OEM-M2) to turn on and lower the output tray guide.

Bench Test Procedure

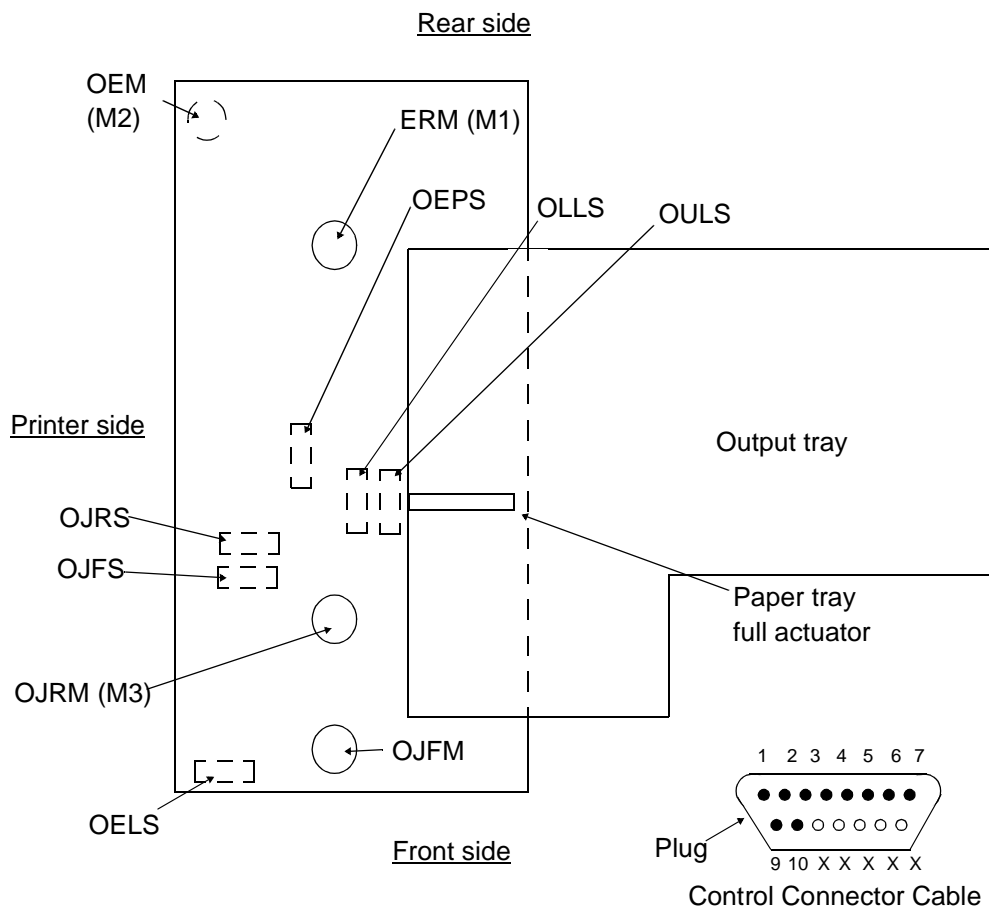

- 11** As the output tray guide reaches its lowest allowable position, photosensor OELS is enabled and signals the output control board to turn the elevator motor (OEM-M2) off.
- 12** Releasing the paper tray full actuator then enables photosensor OULS to signal the output control board to turn the elevator (OEM-M2) on and raise the output tray guide.
- 13** As the output tray guide reaches its highest allowable position, the paper tray full actuator enables both photosensor OLLS and photosensor OULS, which in turn signal the output control board to turn the elevator motor (OEM-M2) off.
- 14** Disconnect the power cord from the stacker, then place a jumper from pin 3 to pin 6 and a second jumper from pin 2 to pin 7.
- 15** Reconnect the power cord, then (from the printer side of the unit) insert a folded piece of paper into the unit to trigger the actuator and enable photosensor OEPS. This will signal the output control board to turn the jogging rear motor (OJRM-M3) on.
- 16** After jogging has occurred, remove the piece of paper then reinsert it. This will again trigger the actuator and enable photosensor OEPS. This will signal the output control board to turn the jogging front motor (OJFM-M4) on.
- 17** The procedure is completed. Disconnect the power cord, remove the jumpers, then reinstall the unit into the printer.

Connector Locations

Front View (cover removed)

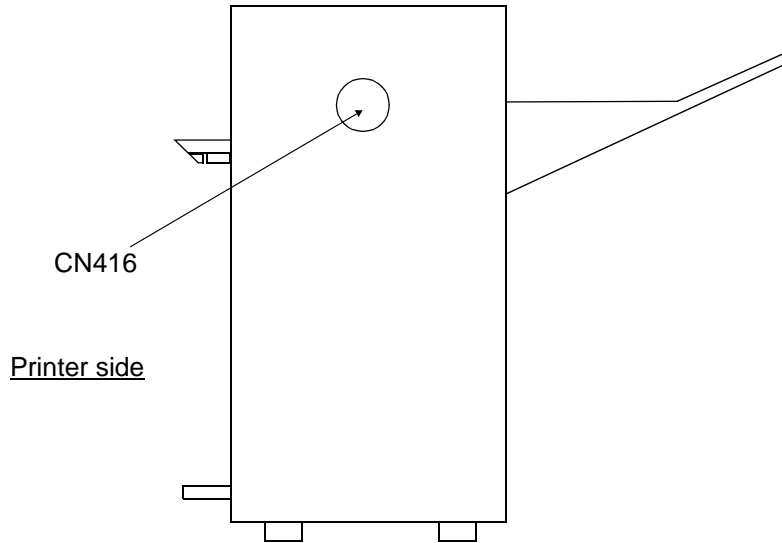

Left Side View (left cover removed)

! Connectors/circuit boards shown with broken lines are concealed from view.

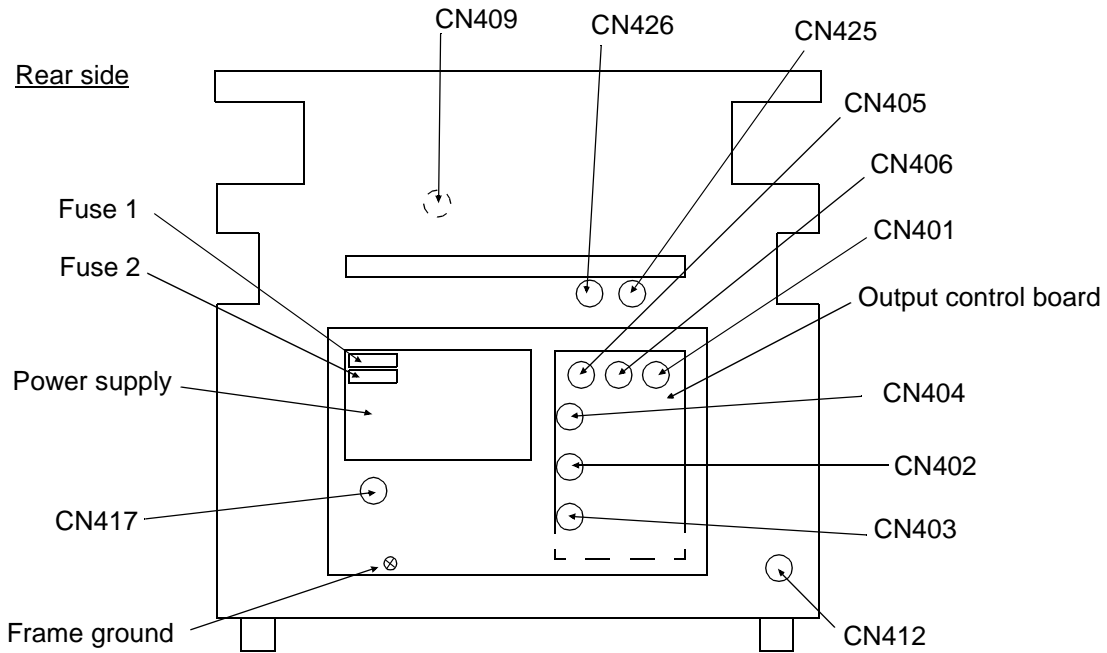

Connector Locations

Rear Side View (cover removed)

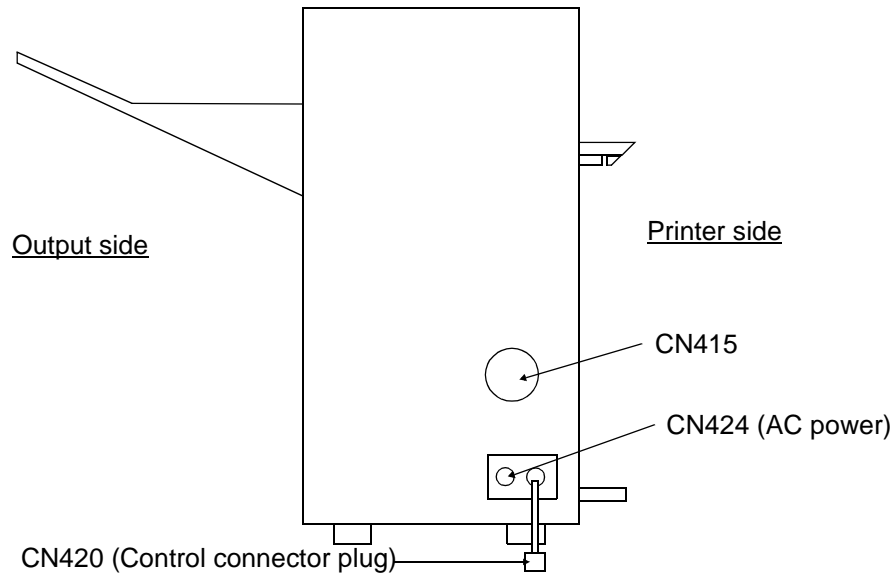

Top View (top cover removed)

! Connectors/circuit boards shown with broken lines are concealed from view.

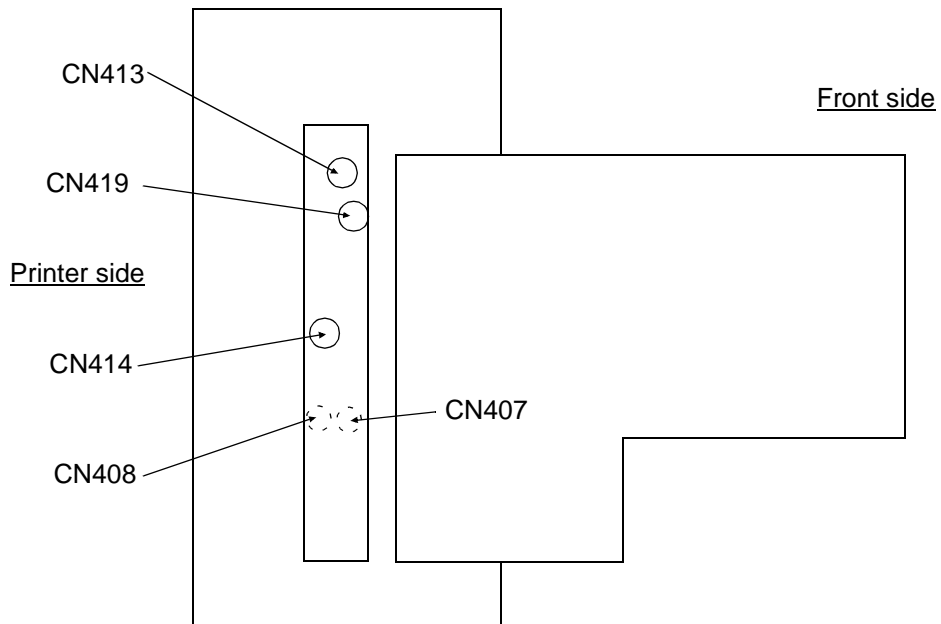

Connection Diagram for the 1400-Sheet Stacker

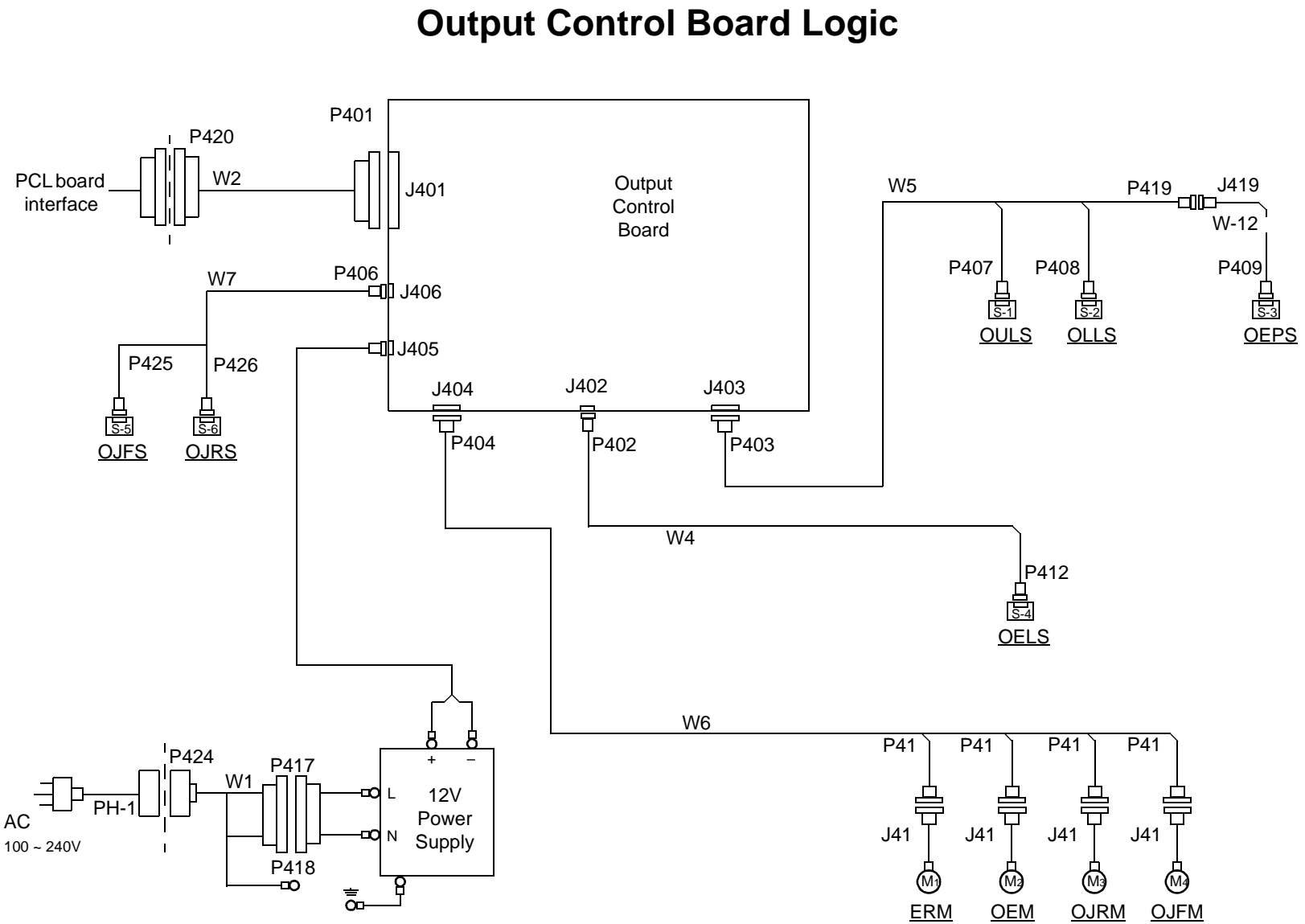

Output Control Board Logic

Output Control Board Logic

The table below details specific stacker actions and which sensors supply the signals needed for each action. Signals from the printer are also included.

| Action | Sensor Input |
|---|--|
| Elevator up (Wait signal to printer) | OULS OLLS OELS |
| Elevator stop | OULS OLLS OELS |
| Remove prints (signal to printer) | OULS OLLS OELS |
| Elevator down | OULS OLLS OELS |
| paper exit | EPS OEPS |
| Paper exit jam (023) | OEPS |
| Jogging start | From printer |
| Jogging | ERS (from printer) OJRS OEPS OJFS |
| Jogging stop | From printer |

General Printer Maintenance

Contents

General Printer Maintenance

| | |
|--|------|
| Introduction | 9-3 |
| Safety Precautions | 9-4 |
| Tool Requirements: Service Kit. | 9-4 |
| Tools/Supplies | 9-5 |
| Printer/Maintenance Record | 9-5 |
| Printer Maintenance Record | 9-6 |
| Every-Call Cleaning Procedure | 9-7 |
| Remove Major Consumable Supplies | 9-7 |
| Inspect and Vacuum | 9-7 |
| Clean Internal Areas | 9-7 |
| Clean the Fuser | 9-7 |
| Clean the Developer | 9-8 |
| Clean the Cleaner/Charge Corona | 9-8 |
| Clean the Photoconductor Area | 9-8 |
| Clean the Transfer Corona | 9-8 |
| Run Test Prints | 9-9 |
| Adjusting Paper Feed Tension | 9-10 |
| Adjusting Registration | 9-11 |
| Lubrication Procedure | 9-12 |
| Front View Lubrication | 9-13 |
| Front View Lubrication Table | 9-14 |
| Rear View Lubrication | 9-15 |
| Rear View Lubrication Table | 9-16 |
| Top View Lubrication | 9-17 |
| Duplex Holding Tray Lubrication | 9-18 |
| Tune-Up Maintenance Procedure. | 9-19 |

Section 9

General Printer Maintenance

Introduction

This section describes the primary printer maintenance procedures to be completed during service calls. In addition, this introduction reviews safety precautions, tool requirements, and the printer maintenance record.

Electrical Checks

Step-by-step instructions for performing several of the checks needed to solve printer problems.

Every-Call Cleaning Procedure

The every-call cleaning procedure, as the name implies, is performed *every* time the printer is serviced. It includes a thorough cleaning of the printer, requiring the removal of all major components and performance of specific cleaning tasks related to each one. It also includes vacuuming all excess toner and other contamination from the interior of the printer.

Paper Feed Tension Adjustment Procedure

You may need to adjust the paper feed tension to correct jamming.

Lubrication Procedures

Lubrication procedures are performed whenever needed, though lubrication should be applied sparingly. The required lubricants, including oil, molycote, red grease, and non-silicon white grease can be purchased from the printer's manufacturer.

Tune-Up Procedure

The tune-up maintenance procedure is performed when the printer has yielded sub-standard prints after you've completed standard maintenance procedures, or has printed one-to two-million images. A tune-up maintenance kit is required for this procedure.

Safety Precautions

Whenever servicing sophisticated electronic/electro-mechanical equipment, common sense, training, caution and experience help in avoiding accidents and mishaps. Be aware of the following safety precautions:

- Follow all instructions in this document.
- Follow all warnings and instructions marked on the printer.
- Unplug the printer when performing any removal, replacement or cleaning procedure.
- Ensure that the power source for the printer matches the power specification label located above the power outlet on the back of the printer.
- Keep combustible materials away from the printer.
- Provide adequate ventilation for the printer so that slots and openings in the cabinet sides are not blocked.
- Do not push objects of any kind through the cabinet slots. They may contact dangerous voltage points or other hazards.
- Do not expose the printer to liquids of any kind.
- Protect the power cord. Do not place it in a traffic pattern or allow anything to rest on it.

Tool Requirements: Service Kit

A service kit intended for use solely by the service technician is shipped inside the right side cover of the printer. This kit includes:

- Interlock by-pass tools (2)
- RS-232C loop back assembly
- RS-422 loop back assembly
- Multimeter jumpers (2)
- Charger cleaner brush

Tools/Supplies

To service the printer properly, you will also need to carry the following:

- Soft cleaning cloth
- Cotton swabs
- Charger cleaner
- Basic set of hand tools suitable for office automation equipment repair
- Service vacuum cleaner, properly grounded and equipped with a 10 micron filter

End User Cleaning Kit

Printers are shipped with an end-user cleaning kit taped inside the front cover. The cleaning kit consists of:

- Cotton swabs
- Charger cleaner brush

This kit is intended for use by the end user.

Printer/Maintenance Record

A maintenance record must be kept for every printer. During the initial service call or at the time of installation, set up a maintenance record for the customer. A copy of the form, illustrated on the following page, should be in a plastic bag taped inside the front cover so that the maintenance form is always easily accessible.

Printer Maintenance Record

Printer Maintenance Record

Completed by user

Completed by HP:

| Page Counter | Operator | HP notified Date/Time | Down time | HP CE on site | Date | Time |
|--------------------------------|----------|-----------------------|-------------------------------------|---------------|------|------|
| | | | | | | |
| Malfunction Description | | | Action Required and Comments | | | |
| | | | | | | |
| | | | | | | |
| Malfunction Description | | | Action Required and Comments | | | |
| | | | | | | |
| | | | | | | |
| Malfunction Description | | | Action Required and Comments | | | |
| | | | | | | |

Every-Call Cleaning Procedure

Perform the every-call cleaning procedure *every* time the printer is serviced. When troubleshooting a printer problem, you may be directed to complete this procedure as you isolate or correct the problem. If the procedure is not specifically called out, always complete it before concluding the service call.

The every-call cleaning procedure begins by removing the major consumable supplies from the printer. When the supplies are out, use a toner vacuum to vacuum the printer thoroughly. Clean each consumable supply, following the instructions listed in this section, before returning it to the printer. Conclude the every-call procedure by running test prints to confirm the print quality.

The location of all major printer supplies and instructions for their removal are outlined later in this manual.

Remove Major Consumable Supplies

- Photoconductor; place it in its protective packaging.
- Cleaner
- Developer
- Fuser

Inspect and Vacuum

- Inspect the areas in the printer around the developer, cleaner, photoconductor, and fuser for damage and wear.
- Vacuum these areas to remove all excess toner, contamination, and/or foreign objects.

Clean Internal Areas

- Clean the erase lamp with a cotton swab.
- Clean the printhead bias plates with a soft cloth.
- Clean the LED lens with a cotton swab, making sure no lint remains on the lens.

Clean the Fuser

! Caution! The fuser may be hot.

- Inspect the fuser for damage and contamination; repair or replace as necessary.
- Clean the fuser connector, both on the fuser and in the printer, with a cotton swab.
- Vacuum in and around the rollers to remove excess toner, contamination, and any foreign objects.
- Reinstall the fuser.

Every-Call Cleaning Procedure

Clean the Developer

- Inspect the developer for damage or contamination; repair or replace as necessary.
- Clean any excess toner from the developer with a soft cloth.
- Clean the toner patch sensor lens with a soft cloth, making sure no lint remains on the lens.
- Vacuum the felt areas around the magnetic roller, being careful not to vacuum toner from the magnetic roller.
- Reinstall the developer.

Clean the Cleaner/Charge Corona

- ! Caution! Handle gently, to avoid breaking the charger wire.
- Inspect the cleaner/charge corona for damage or contamination; repair or replace as necessary.
- Remove the charge corona from the cleaner.
- Clean the grid with the cleaner brush.
- Remove the grid to expose the charger wire.
- Clean the charger wire with a cotton swab.
- Reinstall the grid.
- Clean any excess toner from the cleaner with a soft cloth.
- Reinstall the charge corona in the cleaner.
- Reinstall the cleaner.

Clean the Photoconductor Area

- ! Caution! Do not touch the photoconductor belt, as this *permanently* damages the photoconductor.
- Clean the photoconductor seam sensor inside the printer.
- Remove the photoconductor from its protective packaging.
- Inspect the photoconductor for damage or contamination; repair or replace as necessary.
- Reinstall the photoconductor.

Clean the Transfer Corona

- ! Caution! Handle gently, to avoid breaking the charger wire.
- Remove the transfer corona.
- Clean the transfer corona housing with a soft cloth.
- Clean the transfer corona wire with a cotton swab.
- Reinstall the transfer corona.

Run Test Prints

- Run test prints to verify print quality.

Adjusting Paper Feed Tension

Adjusting Paper Feed Tension

Pressure tension levers can be found inside the front cover, as illustrated below:

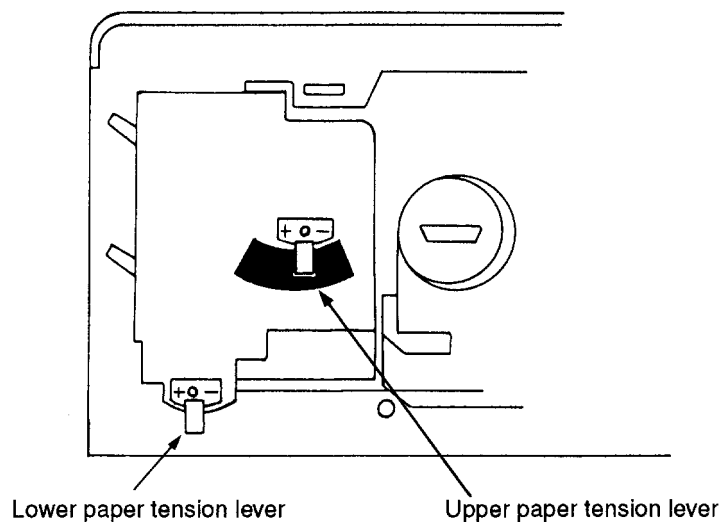

Paper feed tension levers

To adjust the tension:

- 1** Open the printer's front cover.
- 2** Identify the cassette whose tension is to be adjusted, and select the correct lever.
- 3** Adjust the tension:
 - To correct multiple feeds: move the lever toward the minus sign, decreasing the feed pressure.
 - To ease paper feeds: move the lever toward the plus sign, increasing the feed pressure.
- 4** Close the front cover, then print paper from the cassette you are adjusting.
- 5** If the paper is still not feeding properly, repeat Steps 3 and 4 until the feed is properly adjusted.

Adjusting Registration

Registration controls the vertical placement of the printed image on the physical page.

Obtain a test print produced by the C40D printer. Note the 20 line registration indicator at the top of the page. Registration is correct when the twentieth line of the indicator is at the leading edge of the print (plus or minus 2).

! This procedure uses a large amount of paper.

To display the **registration** menu, select the **registration** option from the main menu (labeled **menu**) by using the ◀ and ▶ keys to move the asterisk to it, then press the ▶ key to confirm it.

You will see the following menu:

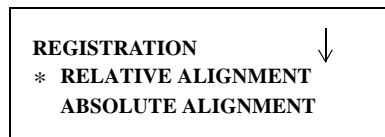

Relative alignment aligns duplex images with relationship to each other. So when you change the alignment, one image will shift up on the page, while the other image shifts down.

Absolute alignment moves both images in the same direction. In this case, when you change the alignment, both images on the page shift either up or down together. They stay the same with relationship to each other, but their position on the physical paper changes.

Use the following guidelines when you are checking or changing the registration, no matter which type of alignment you are using:

- 1 When you select either one of the options on the Registration menu, the printer will immediately begin printing test pages. Wait for about 10-15 pages, then look at an image.
- 2 To shift the image up, press the △ key. To shift the image down, press the ▽ key. Wait for about 15 more pages, then review the image to see if it has shifted enough.
- 3 Continue this until you are satisfied with the result.
- 4 Press the ▶ key. The printer will complete printing the pages left in the buffer.

Lubrication Procedure

Complete the lubrication procedure as-needed. Apply lubrication sparingly. Insufficient lubrication may result in unnecessary noise and premature wear of components; excessive lubrication may contaminate printer supplies and make the printer difficult to keep clean.

The following printer illustrations indicate where lubrication may be required. Charts following the illustrations include symbols that indicate the type of lubricant to use on each component:

- ▼ Oil
- Molycote
- Red grease
- ◆ White grease

For part numbers, refer to the “Additional Parts List” in the *Illustrated Parts Catalog*.

Front View Lubrication

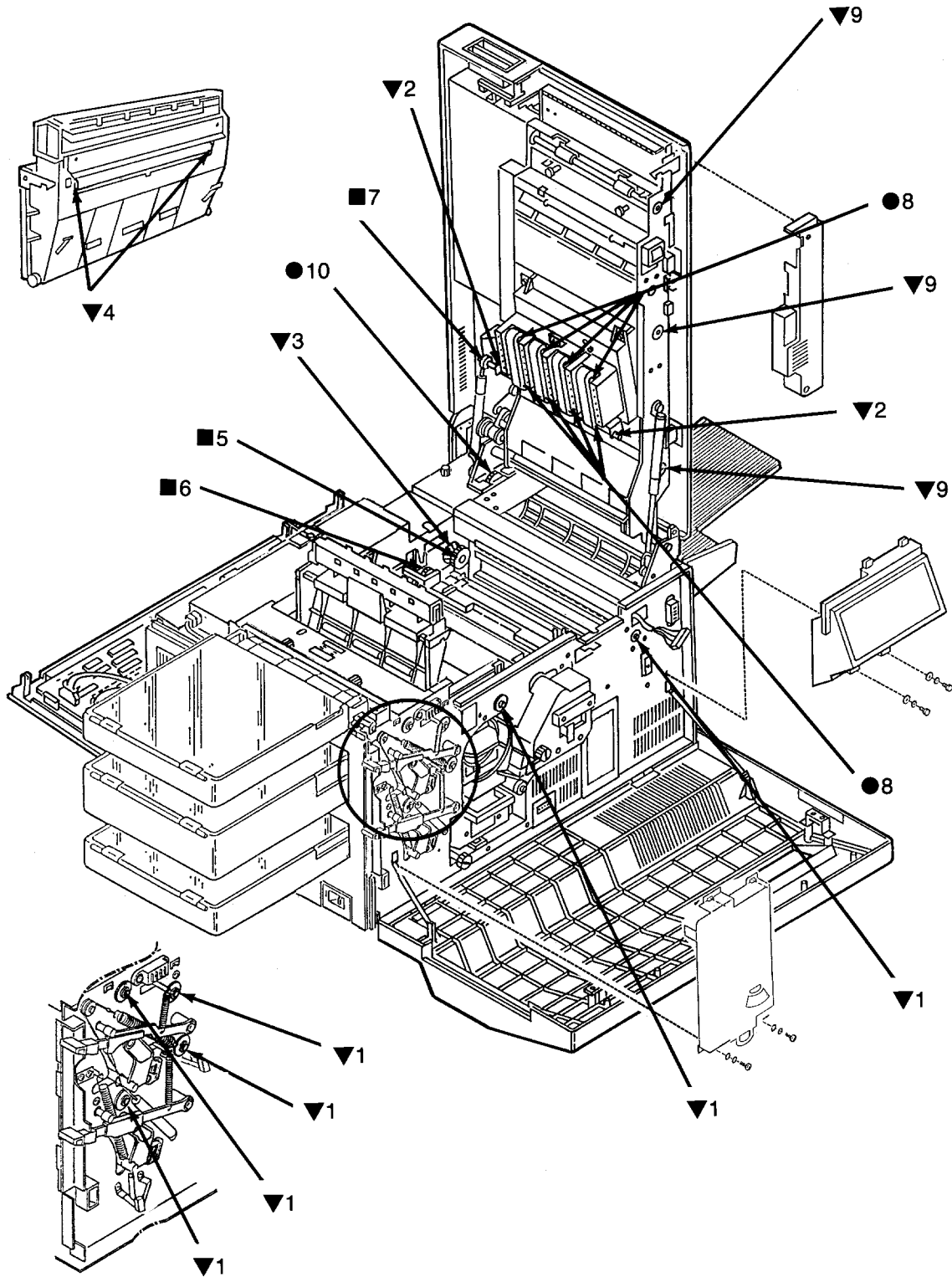

Front View Lubrication Table

| Symbol | Part | Lubricant |
|---------------|---|------------------|
| ▼ 1 | Front roller bearings (paper feed, paper pickup, timing and exit rollers) | Oil |
| ▼ 2 | Vacuum transport drive shaft | Oil |
| ▼ 3 | Fuser drive bearing | Oil |
| ▼ 4 | Upper paper guide roller | Oil |
| ■ 5 | Fuser drive gear | Red grease |
| ■ 6 | Vacuum transport drive gear | Red grease |
| ■ 7 | Vacuum transport gear | Red grease |
| ● 8 | Vacuum transport rollers | Molycote |
| ▼ 9 | Duplex roller bearings | Oil |
| ● 10 | Lower duplex drive assembly | Molycote |

Rear View Lubrication Table

| Symbol | Part | Lubricant |
|--------|--|--------------|
| ▼ 1 | Clutch shafts: upper pick-up roller, lower pick-up roller, upper feed roller, lower feed roller, paper timing roller | Oil |
| ● 2 | Upper and lower pick-up roller drive assemblies | Molycote |
| ● 3 | Main drive gear assembly | Molycote |
| ● 4 | Main drive gear | Molycote |
| ● 5 | Main drive motor gear | Molycote |
| ◆ 6 | Fuser drive gear | White Grease |
| ● 7 | Fuser drive assembly | Molycote |
| ▼ 8 | Clutch shaft bearing | Oil |
| ◆ 9 | Lower duplex drive assembly | White Grease |
| ● 10 | Upper duplex drive assembly | Molycote |
| ● 11 | A roller drive gears | Molycote |
| ● 12 | B roller drive gears | Molycote |
| ● 13 | C roller drive gears | Molycote |
| ◆ 14 | Main Drive Assembly | White Grease |
| ◆ 15 | Idler | White Grease |

Top View Lubrication

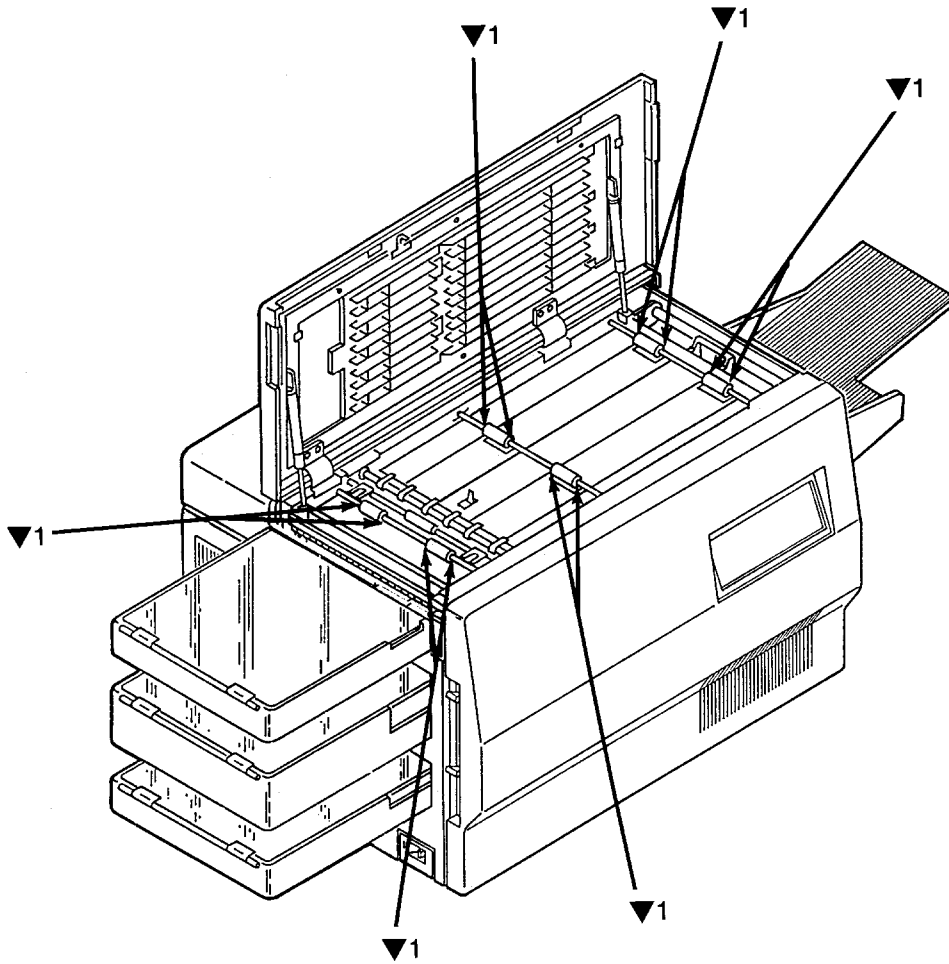

| Symbol | Part | Lubricant |
|--------|----------------------|-----------|
| ▼ 1 | Duplex pinch rollers | Oil |

Duplex Holding Tray Lubrication

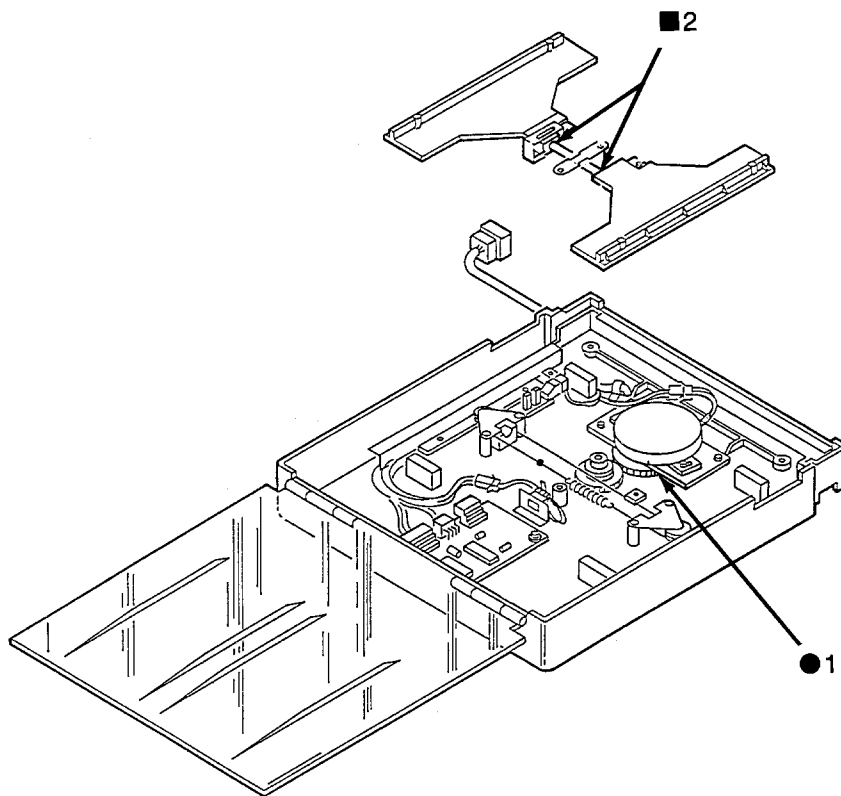

| Symbol | Part | Lubricant |
|--------|-------------|------------|
| ● 1 | Drive gears | Molycote |
| ■ 2 | Tray shaft | Red grease |

Tune-Up Maintenance Procedure

The tune-up maintenance procedure should be performed when the printer: jams frequently; yields sub-standard print quality even after completing regular maintenance procedures; and has printed more than one- or two-million prints. At this point in the life of the printer, the roller assemblies, transfer corona, and static brushes must be replaced. All of the required components are packaged together in a Tune-Up Maintenance Kit.

- 1** For detailed instructions on how to replace each of these components, refer to [Section 7, Removal/Replacement Procedures](#). General guidelines follow for unpacking the component, along with an outline of the order in which the components should be replaced.
- 2** Unpack the maintenance kit, which is shipped in a folded cardboard pack. Remove the shipping carton and unfold the cardboard pack.
- 3** Make sure that you have received all of these replacement components, shown in the following illustration:
 - Roller assembly, lower feed
 - Roller assembly, upper feed
 - Roller assembly, paper timing
 - Roller assembly, exit
 - Roller assembly, upper paper guide
 - Transfer corona
 - Roller assembly, upper pick up
 - Roller assembly, lower pick up
 - Static brush, upper (in cardboard folder)
 - Static brush, lower (in cardboard folder)
 - Label (taped to the top of the package)
 - Duplex Drive Assembly (Not shown)

Tune-Up Maintenance Procedure

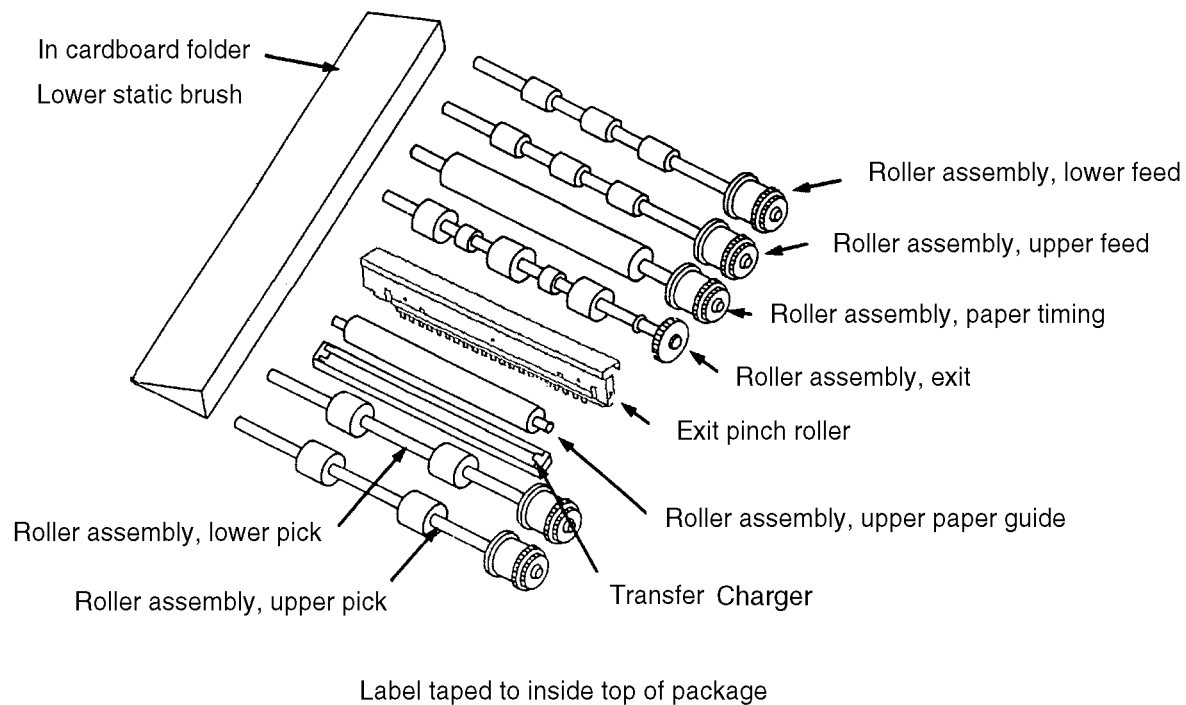

Tune-Up Kit Components

- 4 Unplug the printer.
- 5 Open the top cover.
- 6 Remove the photoconductor and place it in its protective packaging in a safe place away from the work area.
- 7 Replace the component assemblies in this order:
 - Paper timing roller
 - Exit roller
 - Upper pick up roller
 - Lower pick up roller
 - Upper feed roller
 - Lower feed roller
 - Transfer corona
 - Lower static brush
 - Upper static brush
 - Upper paper guide roller
 - Duplex Drive Assembly

Tune-Up Maintenance Procedure

- 8** Perform the every-call cleaning procedure outlined on [page 9-7](#).
- 9** Plug in the printer and turn it on.
- 10** Run test prints to ensure that the paper feeds correctly through the printer.
- 11** Fill in the label with the date and meter count. Affix it inside the front cover next to the printer's serial number.

Tune-Up Maintenance Procedure

Symbols

- “A” roller
 - removal [7-93](#)
- “B” roller
 - removal [7-94](#)
- “C” roller
 - removal [7-96](#)
- “C” roller solenoid
 - removal [7-97](#)

Numerics

- 1200/2500-sheet feeder [8-4](#)
 - bench test [8-5](#)
 - component acronyms [8-4](#)
 - component locations [8-4](#)
 - connection diagram [8-8](#)
 - input control board logic [8-9](#)
 - prefeed adjustment [8-7](#)
- 1400-sheet stacker
 - bench test [8-11](#)
 - component abbreviations [8-10](#)
 - component locations [8-10](#)
 - connection diagram [8-15](#)
 - connector locations [8-13](#)
 - output control board logic [8-15](#), [8-16](#)

A

- AC power supply
 - removal [7-24](#)
- acronyms and abbreviations [1-3](#), [6-9](#)
- automatic toner control [1-10](#)

B

- back cover
 - removal [7-6](#)
- back cover interlock switch
 - removal [7-76](#)

- bit-map RAM
 - error codes [2-10](#)

C

- carrier beads [1-4](#)
- cassette paper present sensor
 - locations [1-8](#)
- cassette present micro switch
 - locations [1-8](#)
- Centronics parallel interface [6-32](#)
 - special considerations [6-32](#)
- charge corona
 - diagnostic test [5-9](#)
 - TAG [3-49](#), [3-52](#)
- cleaner drive
 - removal [7-52](#)
- cleaner drive belt
 - removal [7-51](#)
- cleaning
 - every-call procedure [9-7](#)
- communications malfunctions
 - TAG [3-128](#)
- connector index [6-4](#)
- connector locations [6-11](#)
- connectors
 - back cover [6-17](#)
 - duplex cover [6-14](#)
 - front cover [6-12](#)
 - left cover [6-13](#)
 - right cover [6-15](#)
 - top cover [6-16](#)
- continuity checks [1-17](#)
- controls
 - automatic toner [1-10](#)
- cooling fan
 - removal [7-21](#)
- counter

- diagnostic test [5-7](#)
- removal [7-13](#)
- TAG [3-125](#)
- cross references
 - error code to TAG [2-4](#)
 - mechanical malfunction to TAG [2-14](#)
 - print quality to TAG [2-12](#)

D

- DC power supply
 - removal [7-26](#)
- DCE host interface [6-29](#)
- de-toning [1-12](#)
- developed image, producing [1-18](#)
- developer
 - TAG [3-55](#)
- developer bias
 - TAG [3-36](#)
- developer unit
 - TAG [3-45](#)
- diagnostic tests
 - see Section 5, Diagnostic Tests*
- disk drive
 - diagnostic test [5-18](#)
 - error codes [2-8](#)
 - TAG [3-90](#)
- disk formatting [5-17](#)
- DTE host interface [6-29](#)
- duplex clutch
 - diagnostic tests [5-13](#)
- duplex control board
 - removal [7-86](#), [7-87](#)
- duplex cover interlock switch
 - location [1-9](#)
- duplex motor
 - diagnostic tests [5-11](#)
- duplex paper path sensor
 - location [1-9](#)
 - removal [7-99](#)
- duplex registration sensor
 - location [1-8](#)
- duplex route motor/solenoid assembly

- removal [7-92](#)
- duplex route separator
 - removal [7-98](#)
- duplex sensors
 - diagnostic tests [5-12](#)
- duplex skew correction cable
 - removal [7-89](#)
- duplex tray paper-guide motor
 - diagnostic test [5-13](#)
- duplex tray registration motor
 - removal [7-88](#)

E

- electrophotography [1-3](#)
- end-user cleaning kit [9-5](#)
- EP cover
 - removal [7-79](#)
- erase lamp
 - diagnostic test [5-10](#)
 - removal [7-78](#)
 - TAG [3-58](#)
- error code/TAG cross reference [2-4](#)
- error codes
 - bit-map RAM [2-10](#)
 - defined [1-20](#)–[1-33](#)
 - disk drive [2-8](#)
 - host communication [2-11](#)
 - printer [2-4](#)
 - RIGS board [2-5](#)
 - VPCL board [2-5](#), [2-6](#)
- error log
 - clearing [1-19](#), [3-9](#), [5-18](#)
 - reading [1-13](#)
- exit assembly
 - removal [7-63](#)
- exit cover
 - removal [7-71](#)
- exit pinch roller
 - removal [7-65](#)
- exit roller assembly
 - removal [7-69](#)

F

fan

see *cooling fan*

Flex IO card

TAG 3-131

format disk 5-17

front cover

removal 7-5

front cover interlock switch

removal 7-75

front interlock switch

location 1-11

function code

version number 5-17

fuser

TAG 3-26, 3-66

fuser drive

removal 7-54

fuser drive belt

removal 7-53

fuser thermistor

TAG 3-65

fusing problems

TAG 3-166

G

ground system 6-27

H

hard disk drive housing

removal 7-19

HCI

see *1200/2500-sheet feeder*

HCO

see *1400-sheet stacker*

high voltage power supply

removal 7-27

high-capacity input unit

diagnostic test 5-14

high-capacity output unit

diagnostic test 5-14

host communication

error codes 2-11

host interface

reference 6-28

host system

troubleshooting 1-12

I

image

producing developed 1-18

imaging system 1-3

interfaces

Centronics parallel 6-32

IBM parallel 6-33

IBM PC/AT 6-31

IBM PC/XT 6-30

Macintosh 6-31

RS-232C 6-28

interlock

by-pass tool 1-17

TAG 3-171

L

LED array technology 1-3

LED printhead

diagnostic test 5-15

left side cover

removal 7-7

line power 1-14

loopback connector

diagnostic test 5-16

lower cassette

diagnostic test 5-5

TAG 3-12, 3-17, 3-22, 3-121

lower cassette mount

removal 7-40

lower feed roller

removal 7-58

lower paper guide

removal 7-48

lower pick-up roller

- removal [7-62](#)
- lower static brush
 - removal [7-68](#)
- lubrication
 - procedure [9-12](#)
- lubrication points
 - duplex holding tray [9-18](#)
 - front view [9-13](#)
 - rear view [9-15](#)
 - top view [9-17](#)

M

- main drive motor
 - TAG [3-127](#)
- main gear drive
 - removal [7-85](#)
- main motor
 - removal [7-82](#)
- maintenance
 - every-call cleaning procedure [9-7](#)
 - lubrication procedure [9-12](#)
 - paper feed tension [9-10](#)
- mechanical malfunction
 - TAG cross reference [2-14](#)

N

- negative developer bias
 - diagnostic test [5-11](#)

O

- operator panel
 - diagnostic test [5-4](#)
 - removal [7-12](#)
 - TAG [3-112](#)
- output tray
 - TAG [3-115](#)

P

- paper exit sensor
 - location [1-10](#)
 - removal [7-73](#)
- paper feed drive belt

- removal [7-55](#)
- paper feed tension
 - adjusting [9-10](#)
- paper full sensor
 - location [1-10](#)
 - removal [7-74](#)
- paper jams
 - fuser area [3-26](#)
 - lower cassette [3-22](#)
 - output area [3-30](#)
 - transfer area [3-26](#)
 - upper cassette [3-19](#)
- paper path [1-5](#)
 - illustrated [1-6](#)
- paper problems
 - damaged [3-123](#)
 - input area [3-32](#)
 - multiple feeds [3-122](#)
 - output area [3-34](#)
- paper size
 - TAG [3-117](#)
- paper size sensor
 - locations [1-9](#)
 - removal [7-34](#)
- paper timing guide
 - removal [7-49](#)
- paper timing roller
 - removal [7-56](#)
- paper timing sensor
 - location [1-9](#)
- PC life data
 - TAG [3-54](#)
- photoconductor
 - cautions [7-4](#)
 - removal [7-4](#)
- photoconductor rear guide rail
 - removal [7-30](#)
- photoconductor seam sensor
 - diagnostic test [5-8](#)
 - location [1-10](#)
 - removal [7-28](#)

- TAG 3-46
- pick-up roller drive gear
 - removal 7-61
- pick-up roller drive idler
 - removal 7-60
- power control board
 - removal 7-33
- power problems
 - +12 Vdc 3-68
 - +24 Vdc 3-80
 - +5 Vdc 3-100
 - 12 Vdc 3-78
 - ac input 3-105
 - TAG 3-68, 3-78, 3-80, 3-100, 3-105
- power-on-reset 1-17
- print problems
 - background 4-21
 - black print 4-13
 - blank print 4-6
 - blank vertical bands 4-11
 - blurring 4-19
 - dark areas 4-14
 - dark lines 4-14
 - dark print 4-13
 - dark specks 4-14
 - dark vertical lines 4-15
 - density variations 4-20
 - light horizontal bands 4-12
 - light print 4-7, 4-8
 - light vertical streaks 4-10
 - misregistration 4-17
 - overtone print 4-18
 - residual images 4-22
 - skewed prints 4-16
 - toner fusing 4-24
 - voids 4-9
 - washout 4-5
 - white spots 4-9
 - wrinkled sheets 4-23
- print quality
 - samples, *see Section 4*

- TAG cross reference 2-12
- printer
 - error codes 2-4
- printer maintenance
 - logs 9-6
 - safety precautions 9-4
 - supplies 9-5
 - tools 9-4
- printhead
 - TAG 3-170
- printhead assembly
 - removal 7-16
- printhead circuit board
 - removal 7-18
 - settings 6-3
- printing process 1-3
- problem resolution
 - TAG 3-7
- protocol converters 1-13

R

- rear duplex cover
 - removal 7-10
- rear interlock switch
 - location 1-9
- right side cover
 - removal 7-8
- RIGS board
 - diagnostic test 5-16
 - error codes 2-5
 - removal 7-14
- RIGS controller
 - overview 1-3
 - TAG 3-95, 3-97, 3-99
- roller clutch
 - diagnostic test 5-7
- RS-232C interface 6-28

S

- safety precautions 9-4
- self-diagnostic mode 5-3

- sensors
 - diagnostic tests 5-6
 - duplex paper path 1-9
 - duplex registration 1-8
 - locations 1-8
 - lower cassette paper present 1-8
 - lower paper size 1-9
 - paper exit 1-10
 - paper full 1-10
 - paper timing 1-9
 - photoconductor seam 1-10
 - toner empty 1-10
 - toner patch 1-9
 - upper cassette paper present 1-8
 - upper paper size 1-9
- service call, completing 1-19
- service kit 9-4
- switches
 - bypassing interlock 1-17
 - duplex cover interlock 1-9
 - front interlock 1-11
 - locations 1-8
 - lower cassette present 1-8
 - rear interlock 1-9
 - top interlock 1-10
 - upper cassette present 1-8

T

- TAGs
 - sample 1-15
 - using 1-15
- test prints
 - running 1-12, 3-8
- toner
 - automatic control 1-10
 - TAG 3-43
- toner empty sensor
 - location 1-10
- toner motor
 - diagnostic test 5-8
 - removal 7-22

- toner patch
 - producing 1-18
 - TAG 3-39, 3-41
- toner path sensor
 - location 1-9
- top cover interlock switch
 - removal 7-77
- top interlock switch
 - location 1-10
- transfer area
 - TAG 3-26
- transfer corona
 - diagnostic test 5-9
 - TAG 3-49, 3-56
- troubleshooting
 - general tips 1-12
 - overview 1-11
 - TAG 3-5
- tune-up
 - maintenance procedure 9-19
- tune-up kit
 - components 9-20

U

- upper cassette
 - diagnostic test 5-4
 - TAG 3-10, 3-14, 3-19, 3-120
- upper cassette mount
 - removal 7-35
- upper duplex drive/clutch assembly
 - removal 7-91
- upper feed roller
 - removal 7-57
- upper paper guide
 - assembly 3-124
 - removal 7-45
- upper pick-up roller
 - removal 7-59
- upper static brush
 - removal 7-67

V

vacuum transport unit

removal [7-9](#)

voltage isolation diagrams [6-22–6-26](#)

VPCL board

error codes [2-5](#), [2-6](#)

overview [1-3](#)

removal [7-15](#)

TAG [3-89](#), [3-97](#)